

## WARNING AND CAUTIONS:

- **TO AVOID FIRE, SHOCK, OR DEATH: TURN OFF POWER AT CIRCUIT BREAKER OR FUSE AND TEST THAT POWER IS OFF BEFORE INSTALLING!**
- **PROPER GROUNDING REQUIRED TO AVOID STATIC DISCHARGE WHICH CAN DAMAGE CONTROLLERS DURING INSTALLATION.**

## WARNING AND CAUTIONS:

- If you are unsure about any part of these instructions, consult an electrician; all work should be performed by qualified personnel.
- DIM10-087-06-A controllers must be installed in accordance with national, state, and local electrical codes and requirements.

## INSTALLATION GUIDE

### SPECIFICATIONS

- Dim Control Max Load: 10 mA Source/Sink
- Radio Frequency: 2.4 GHz (IEEE 802.15.4)
- RF Transmission Output Power: +20 dBm
- Operating Temperature: -40°C to +80°C
- Operating Humidity: 10 to 90%, non-condensing
- Max D4i Drivers: Limited to 4 D4i LED drivers
- Wire Size: 20 AWG, 7" Wires, 600V
- Dimensions: 3.05" L x 2.21" W x .47" H  
(77.6 x 56.1 x 11.8 mm)

### DESIGN CONSIDERATIONS

Below are some recommendations for successful dimming using the DIM10-087-06-A. The dimming control wires are referenced as DIM+ and DALI-/COM. The dimming signals have a Maximum voltage of 10V DC.

- Do not ground the DALI-/COM wire to chassis ground; this is a return signal and is critical for proper dimming.
- Route dimming wires away from AC lines if possible.
- Maximum of 4 DALI-2/D4i LED Drivers per controller, consult Synapse Support if a greater ratio is needed.
- Maximum of 8 DIM to OFF LED Drivers for DIM to OFF Designs.
- Do not mount to a heatsink or to an LED driver.
- When installing the DIM10-087-06-A into an enclosure, consideration of the external antenna position and any interference is required to provide the best wireless signal strength. Prior to permanently mounting it, make sure the antenna points directly upward or downward and is free of any metal objects within 2 inches of the antenna (Figure 1).

**NOTE:** LED Driver must support DIM to OFF functionality.

**WARNING:** The maximum number of D4i LED Drivers with active DALI power supply on the bus is 4. Up to 6 D4i LED drivers may be on the bus, but only 4 may have active power supplies. SimplySnap will not support more than 6 D4i LED drivers on the Synapse lighting controller. The DALI bus is limited to 250mA. Having more than 4 DALI power supplies on the bus may void the D4i LED driver warranty.

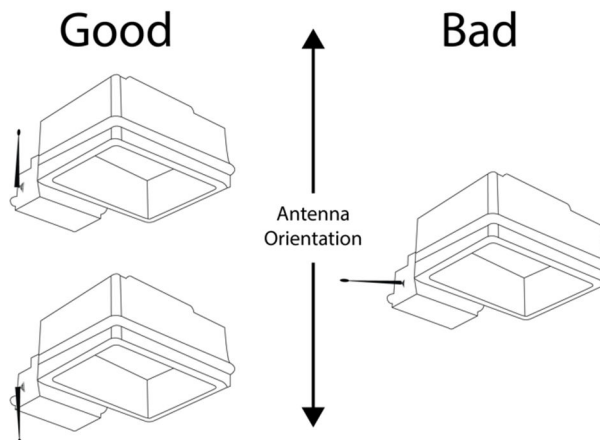

**Figure 1 - Proper Antenna Installation**

### NEEDED MATERIALS

- **Mounting Hardware:** (2) #4 or M3 screws recommended.
- **Antenna Kit:** For available antenna options please refer to our latest documents located on our website.  
[www.synapsewireless.com/documentation](http://www.synapsewireless.com/documentation)

### INSTALLATION INSTRUCTIONS

#### MOUNTING

1. Place the controller in desired location and secure it using #4 or M3 sized screws using the mounting holes located on the back edge of the DIM10-087-06-A.

#### ATTACHING THE ANTENNA

2. Make sure the power is off. When handling the antenna cable, the technician must be grounded with a proper ground strap.
3. Remove red rubber dust cover, the washer, and nut from the antenna connector.
4. Determine the best location for external antenna position and create an opening to mount the antenna and bulkhead (See Figure 2 for measurements).
5. Feed the bulkhead through the opening in the fixture. (Note: Recommended max thickness of fixture wall is 6mm or 0.25 inches. This allows enough threads on the outside of the fixture for a good antenna connection.)
6. Place the washer and the nut back on the antenna connector and secure to fixture.
7. Screw on the antenna hand tight. Tighten a 1/4 turn with a pair of needle nose pliers. Do not over tighten or the RF pin in the bulkhead will crack, creating poor RF link quality.

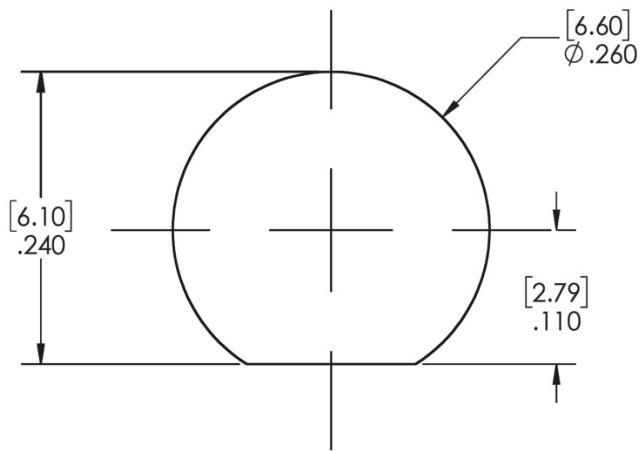

**Figure 2 – Recommended mounting hole for 1/4-36UNS-2A threaded antenna**

## WIRING THE DIM10-087-06-A CONTROLLER

**Note: Unless specified, the connections to a standard Dim to Off LED driver and the DALI 2 LED driver are the same.**

- Connect the 12-24VDC Aux output from the LED driver to the (POWER = RED wire of the DIM10-087-06-A).
- Connect the (COMMON/DIM- = BLACK) wire of the DIM10-087-06-A to the COMMON wire on the LED driver you have.

## CONNECTING SENSORS

**Note: Steps 10-14 are for adding sensors to the DIM10-087-06-A controller; if you are not connecting sensors skip this section.**

There are two sensor inputs on the DIM10-087-06-A designed for low powered (24V DC) type sensors.

- The (SENSOR A = BLUE) wire is used to connect sensor A.
  - The (SENSOR B = ORANGE) wire is used to connect sensor B.
- Connect the sensor power wire to the AUX out on the LED driver (the LED driver powers the sensor).
  - Connect the sensor common to the COMMON/DIM-.

- Connect the sensor CTRL/Control wire to the (SENSOR A = BLUE) wire or the (SENSOR B = ORANGE) wire of the DIM10-087-06-A controller.
- If you are using more than one sensor, then duplicate the installation as described above.
- Sensors must be configured in software before they are functional in a SimplySnap system. (See Figures 3 and 4)

## CONNECTING THE DIMMING CIRCUIT

**Note: Steps 15-16 are for connecting to a Standard Dim to Off LED driver; if you are using a DALI 2 LED driver skip to steps 17-18.**

- Connect the (DIM+ = PURPLE) wire from the DIM10-087-06-A to the DIM+ wire on the LED driver.
- Cap unused (DALI- = BROWN) and (DALI+ = YELLOW) wires. (See Figure 3)

**Note: Steps 17-18 are for connecting to a DALI 2 LED driver.**

- Connect the (DALI+ = YELLOW) wire from the DIM10-087-06-A to the LED driver DALI+.
- Cap the unused (DIM+ = PURPLE) wire. (See Figure 4)

## POWERING UP THE FIXTURE AND CONTROLLER

After connecting the Controller to the LED Driver and any sensors, make sure to cap any unused wires. Switch power on to the fixture. The light should turn on.

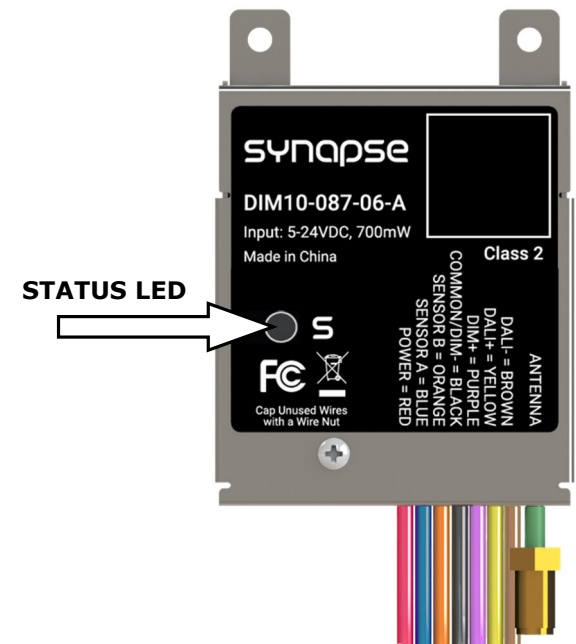

## STATUS LED

**Note: When the controller is powered, the following colors indicate the status.**

- Red** = No Network Found (Communication Lost)
- Blinking Green** = Network Found, Controller Not Configured (Device not yet added to SimplySnap)
- Green** = Network Found, Controller Configured (Normal Operation)

For more information on SimplySnap and the DIM10-087-06-A, refer to the website at <http://help.synapsewireless.com/>.

**Figure 3 - DIM to OFF Wiring Diagram**

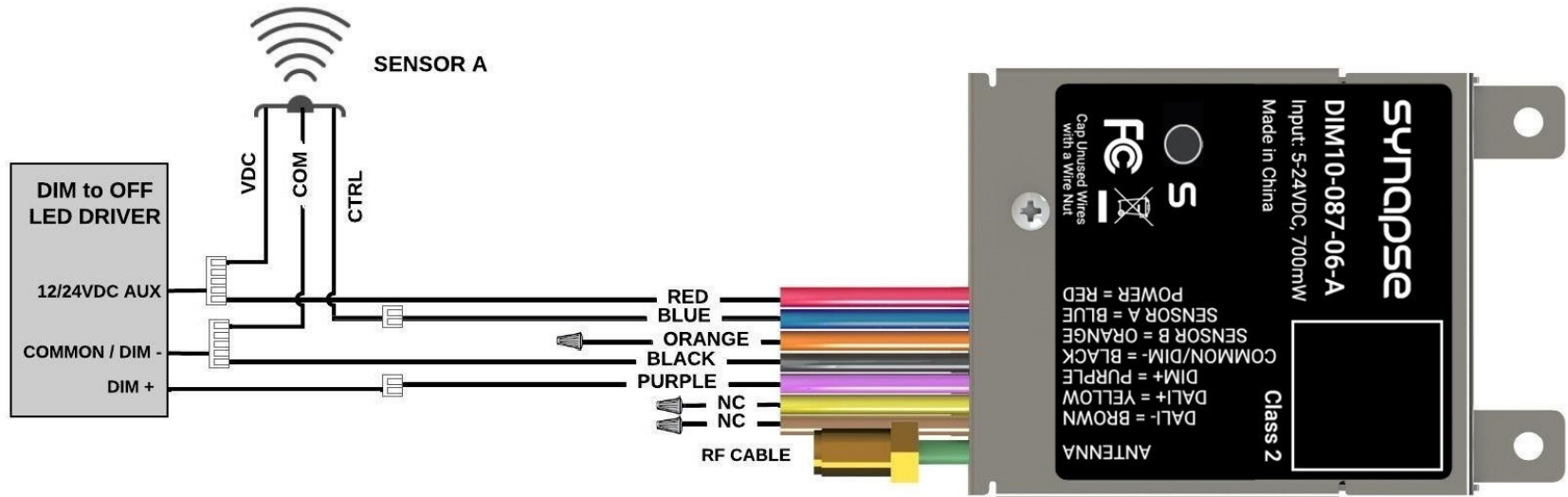

**WARNING:**

- If a single Synapse controller is used to drive the DIM+ input of multiple LED drivers, then all of the DIM- lines from all drivers MUST be directly tied/shorted together to provide a common return/ground to the controller.
- Synapse will not warranty or be liable for designs with any other electronic means of coupling DIM- lines from multiple drivers.

**Figure 4 - DALI-2 Wiring Diagram**

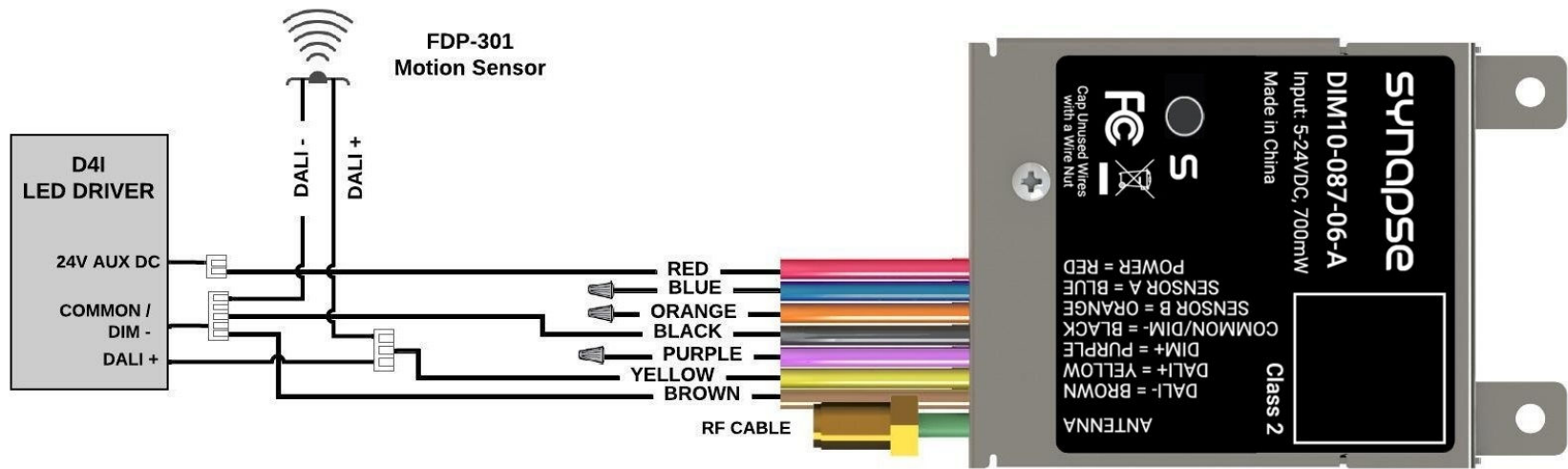

## REGULATORY INFORMATION AND CERTIFICATIONS

**RF Exposure Statement:** This equipment complies with FCC radiation exposure limits set forth for an uncontrolled environment. This equipment should be installed and operated with minimum distance of 20cm between the radiator and your body. This transmitter must not be co-located or operating in conjunction with any other antenna or transmitter.

**Industry Canada (IC) certifications:** This digital apparatus does not exceed the Class B limits for radio noise emissions from digital apparatus set out in the Radio Interference Regulations of the Canadian Department of Communications.

Le présent appareil numérique n'émet pas de bruits radioélectriques dépassant les limites applicables aux appareils numériques de la classe B prescrites dans le Règlement sur le brouillage radioélectrique édicté par le ministère des Communications du Canada.

### FCC certifications and regulatory information (USA only)

**FCC Part 15 Class B:** This device complies with part 15 of the FCC rules. Operation is subject to the following two conditions: (1) These devices may not cause harmful interference, and (2) These devices must accept any interference received, including interference that may cause harmful operation.

**RADIO FREQUENCY INTERFERENCE (RFI) (FCC 15.105):** This equipment has been tested and found to comply with the limits for a Class B digital device, pursuant to Part 15 of the FCC rules. These limits are designed to provide reasonable protection against harmful interference in a residential installation. This equipment generates, uses, and can radiate radio frequency energy and, if not installed and used in accordance with the instructions, may cause harmful interference to radio communications. However, there is no guarantee that interference will not occur in a particular installation. If this equipment does cause harmful interference to radio or television reception, which can be determined by turning the equipment off and on, the user is encouraged to try to correct the interference by one or more of the following measures: (1) Re-orient or relocate the receiving antenna; (2) Increase the separation between the equipment and the receiver; (3) Connect the equipment into an outlet on a circuit different from that to which the receiver is connected; (4) Consult the dealer or an experienced radio/TV technician for help.

### Declaration of Conformity (FCC 96-208 & 95-19):

Synapse Wireless, Inc. declares that the product name "DIM10-087-06-A" to which this declaration relates, meet the requirements specified by the Federal Communications Commission as detailed in the following specifications:

- Part 15, Subpart B, for Class B equipment
- FCC 96-208 as it applies to Class B personal computers and peripherals
- This product has been tested at an External Test Laboratory certified per FCC rules and has been found to meet the FCC, Part 15, Emission Limits. Documentation is on file and available from Synapse Wireless, Inc.

If the FCC ID for the module inside this product enclosure is not visible when installed inside another device, then the outside of the device into which this product is installed must also display a label referring to the enclosed module FCC ID. Modifications (FCC 15.21): Changes or modifications to this equipment not expressly approved by Synapse Wireless, Inc., may void the user's authority to operate this equipment.

### CERTIFICATIONS

**Model** : DIM10-087-06-A  
**Contains FCC ID** : U90-SM220  
**Contains IC** : 7084A-SM220  
**UL File No** : E346690  
**DALI-2 Certified Application Controller**  
**CE**  
**UKCA**

**Contact Synapse for Support-** (877) 982-7888

Patented – virtual marking at

<https://www.synapsewireless.com/about/patents>