

2

1

REV.	DESCRIPTION	DATE	APPROVED
A	INITIAL RELEASE	7/25/2022	PF

B

B

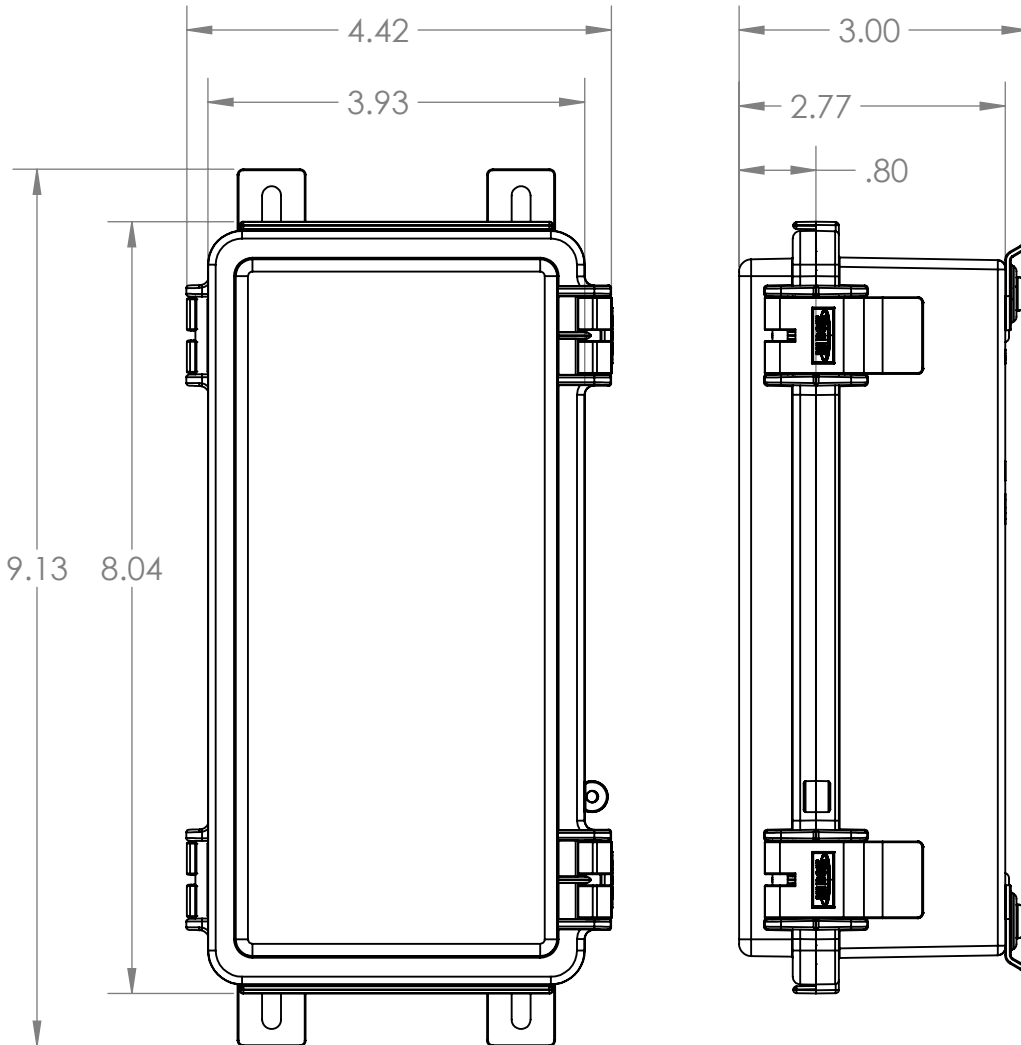

A

A

NOTES:

1. FOR REFERENCE ONLY. THE USER OF THIS DOCUMENT ASSUMES ALL RESPONSIBILITY FOR VERIFYING THE INFORMATION PROVIDED HEREIN.

<p>PROPRIETARY AND CONFIDENTIAL</p> <p>THE INFORMATION CONTAINED IN THIS DRAWING IS THE SOLE PROPERTY OF <COMPANY NAME>. ANY REPRODUCTION IN PART OR AS A WHOLE WITHOUT THE WRITTEN PERMISSION OF <COMPANY NAME> IS PROHIBITED.</p>			<p>DIMENSIONS ARE IN INCHES TOLERANCES: FRACTIONAL ANGULAR: MACH BEND TWO PLACE DECIMAL THREE PLACE DECIMAL</p>		NAME	DATE	<p>SYNAPSE</p> <p>BRIDGE-485</p>
					DRAWN		
					CHECKED		
					ENG APPR.		
					MFG APPR.		
			MATERIAL				
			FINISH				
	NEXT ASSY	USED ON			Q.A.		
	APPLICATION		DO NOT SCALE DRAWING		COMMENTS:		
					SIZE	DWG. NO.	REV.
					Mechanical_Datasheet_485		
					SCALE:1:4	WEIGHT:	SHEET 1 OF 1

2

1