



HECTOR FINCH

ENGLISH HALL LANTERN



PRODUCT CODE LA13

CATEGORY: HANGING LANTERNS

DIMENSIONS

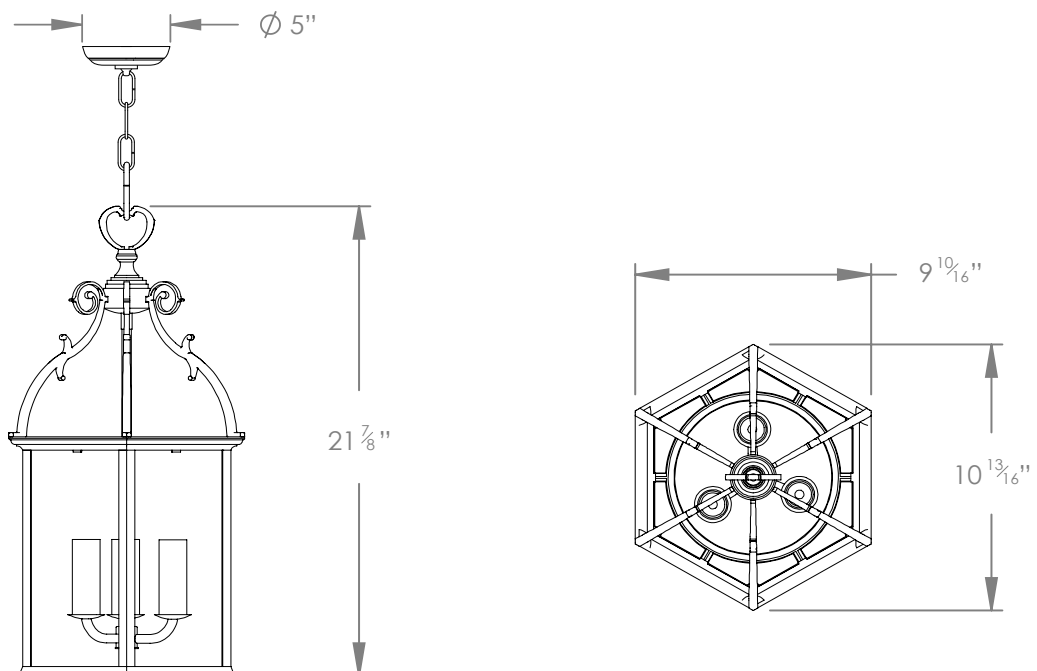



PRODUCT CODE LA13

CATEGORY: HANGING LANTERNS

ENGLISH HALL LANTERN

LAMP TYPE**USA**
3 x 40W E12 Candelabra

FINISH OPTIONS

Brass Polished Lacquered, Brass Polished Unlacquered, Antique Brass, Bronze, Chrome, Nickel Polished (shown) and Nickel Matte.

SIZE & SIMILAR OPTIONS

English Hall Lantern Large (LA14).

WEIGHT

10lb 6oz

ACCREDITATION

This product is UL certificated.



ADDITIONAL INFORMATION

Supplied with 23" of chain and canopy as standard.

CLEANING AND MAINTENANCE INSTRUCTIONS

Glass:
Remove the glass where it is safe to do so. The glass then can be cleaned with a glass cleaner and a lint free cloth. Do not spray glass cleaner directly on the glass or fixture as it could affect the metal finish. Ensure the light is switched off and take care not to pull the flex or allow water to come into contact with the electrical components. Regular dusting with a feather duster will also help keep the glass clean.

Metalwork:
We recommend a light polish with a non-abrasive lint free cloth. Do not use any metal cleaning products on the fixture as it can remove the finish entirely. Unlacquered brass finish will patinate slowly over time and can be brightened to brass by the use of a brass cleaning agent.