



HECTOR FINCH

## HAMMERED GLASS GLOBE LARGE



PRODUCT CODE PL22L

CATEGORY: CHANDELIERS & PENDANTS

### DIMENSIONS

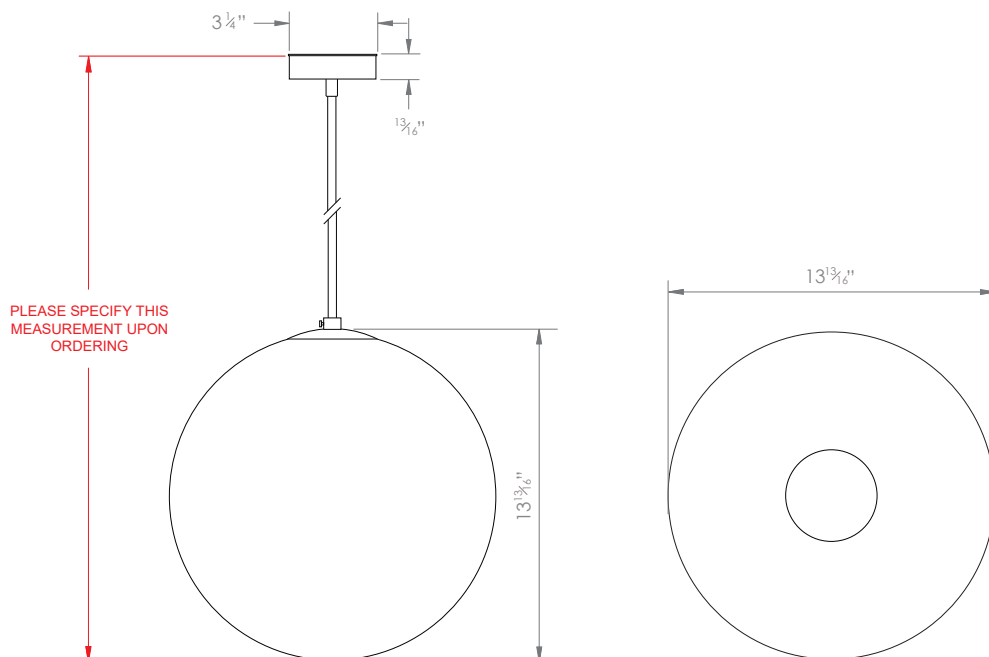



PRODUCT CODE PL22L

CATEGORY: CHANDELIERS & PENDANTS

---

## HAMMERED GLASS GLOBE LARGE

---

<b>LAMP TYPE</b>	<b>USA</b> 1 x 60W (Max) E26 General Service
<b>FINISH OPTIONS</b>	Brass Polished Lacquered, Brass Polished Unlacquered, Antique Brass (shown), Bronze, Chrome, Nickel Polished and Nickel Matte.
<b>WEIGHT</b>	11lb
<b>ACCREDITATION</b>	This product is UL certificated. 
<b>CLEANING AND MAINTENANCE INSTRUCTIONS</b>	<p>Glass: Remove the glass where it is safe to do so. The glass then can be cleaned with a glass cleaner and a lint free cloth. Do not spray glass cleaner directly on the glass or fixture as it could affect the metal finish. Ensure the light is switched off and take care not to pull the flex or allow water to come into contact with the electrical components. Regular dusting with a feather duster will also help keep the glass clean.</p> <p>Metalwork: We recommend a light polish with a non-abrasive lint free cloth. Do not use any metal cleaning products on the fixture as it can remove the finish entirely. Unlacquered brass finish will patinate slowly over time and can be brightened to brass by the use of a brass cleaning agent.</p>