



HECTOR FINCH

ZEUS HANGING LANTERN ON BRACKET LARGE



PRODUCT CODE WL293L

CATEGORY: LANTERNS ON BRACKETS

DIMENSIONS

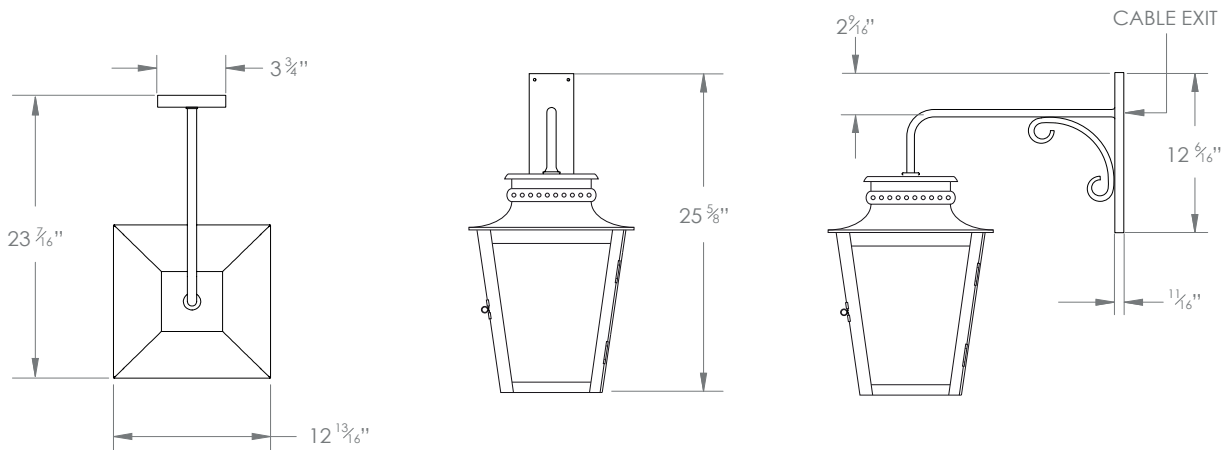



PRODUCT CODE WL293L

CATEGORY: LANTERNS ON BRACKETS

ZEUS HANGING LANTERN ON BRACKET LARGE

LAMP TYPE	USA 4 x Osh Lamp with 33W (Max) G9 halogen
FINISH OPTIONS LAMP	Antique Brass, Black and Zinc (shown).
FINISH OPTIONS BRACKET	Black and Galvanized Steel (shown).
SIZE & SIMILAR OPTIONS	Zeus Lantern on Lower Bracket (WL295), Zeus Hanging Lantern on Bracket Small (WL293S) and Zeus Hanging Lantern on Bracket Medium (WL293M).
WEIGHT	16lb 16oz
ACCREDITATION	This product is UL certificated. 
ADDITIONAL INFORMATION	Suitable for outdoor use. The Zinc finish is made out of sheet zinc which is then acid washed to achieve a matte finish while the Galvanized Steel is a protective zinc coating to steel.
CLEANING AND MAINTENANCE INSTRUCTIONS	<p>Glass: Remove the glass where it is safe to do so. The glass then can be cleaned with a glass cleaner and a lint free cloth. Do not spray glass cleaner directly on the glass or fixture as it could affect the metal finish. Ensure the light is switched off and take care not to pull the flex or allow water to come into contact with the electrical components. Regular dusting with a feather duster will also help keep the glass clean.</p> <p>Metalwork: We recommend a light polish with a non-abrasive lint free cloth. Do not use any metal cleaning products on the fixture as it can remove the finish entirely. Unlacquered brass finish will patinate slowly over time and can be brightened to brass by the use of a brass cleaning agent.</p>