



HECTOR FINCH

SIR JOHN SOANE LANTERN WITH ROOF ON HOOP BRACKET LARGE



PRODUCT CODE WL460L

CATEGORY: WALL LANTERNS

DIMENSIONS

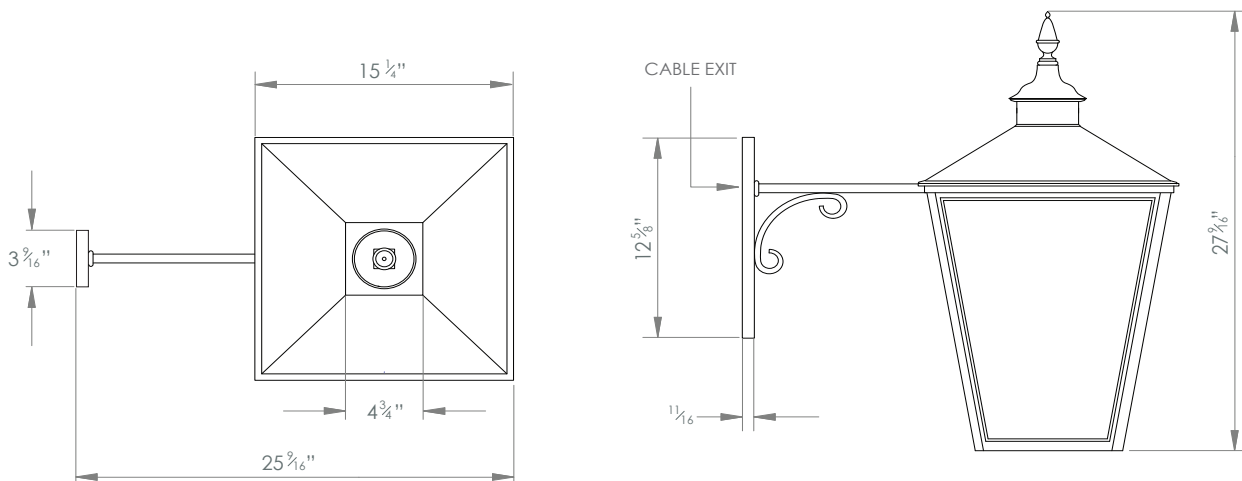



PRODUCT CODE WL460L

CATEGORY: WALL LANTERNS

SIR JOHN SOANE LANTERN WITH ROOF ON HOOP BRACKET LARGE

LAMP TYPE	UK / EU 4 x 40W (Max) E12 Candelabra
FINISH OPTIONS	Antique Brass (shown), Bronze and Zinc.
SIZE & SIMILAR OPTIONS	Sir John Soane Hanging Lantern With Roof on Hoop Bracket, Small (WL460), Sir John Soane Wall Lantern (WL275) and Sir John Soane hanging Lantern (LA92).
ACCREDITATION	This product is UL certificated. 
CLEANING AND MAINTENANCE INSTRUCTIONS	<p>Glass: The glass can be cleaned with a glass cleaner and a lint free cloth. Do not spray glass cleaner directly on the glass or fixture as it could affect the metal finish. Ensure the light is switched off and take care not to pull the flex or allow water to come into contact with the electrical components. Regular dusting with a feather duster will also help keep the glass clean.</p> <p>Metalwork: We recommend a light polish with a non-abrasive lint free cloth. Do not use any metal cleaning products on the fixture as it can remove the finish entirely. Unlacquered brass finish will patinate slowly over time and can be brightened to brass by the use of a brass cleaning agent.</p>