



HECTOR FINCH

ATHENA LANTERN ON HOOP BRACKET SMALL



PRODUCT CODE WL470S

CATEGORY: WALL LANTERNS

DIMENSIONS

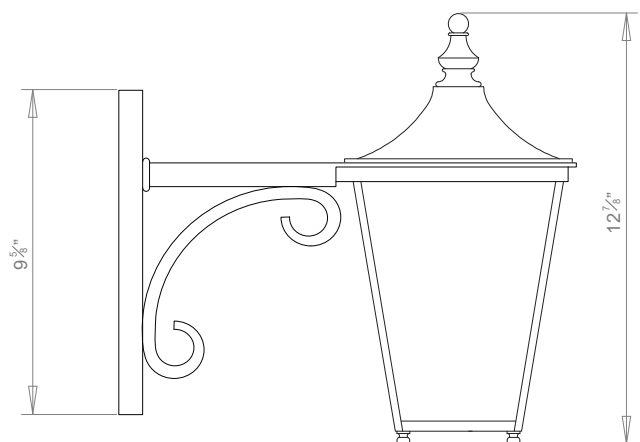
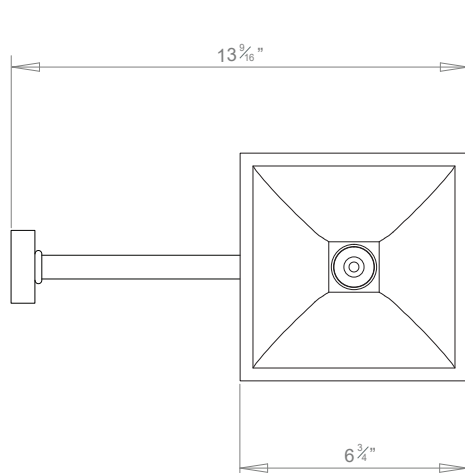



PRODUCT CODE WL470S

CATEGORY: WALL LANTERNS

ATHENA LANTERN ON HOOP BRACKET SMALL

LAMP TYPE	USA 1 x 60W (Max) E12 General Service
FINISH OPTIONS	Antique Brass, Bronze, Nickel Polished and Zinc (shown).
SIZE & SIMILAR OPTIONS	Athena Hanging Lantern (LA412), Athena Wall Lantern (WL430) and Athena Lantern on Post Mount (WL472).
CLEANING AND MAINTENANCE INSTRUCTIONS	<p>Metalwork: We recommend a light polish with a non-abrasive lint free cloth. Do not use any metal cleaning products on the fixture as it can remove the finish entirely.</p> <p>Glass: Remove the glass where it is safe to do so. The glass then can be cleaned with a glass cleaner and a lint free cloth. Do not spray glass cleaner directly on the glass or fixture as it could affect the metal finish. Ensure the light is switched off and take care not to pull the flex or allow water to come into contact with the electrical components. Regular dusting with a feather duster will also help keep the glass clean.</p>