

firainternational



Welcome to FIRA International

Health and Safety

firainternational



Agenda for today

1 .

About Element and FIRA International

2 .

Testing and FIRA Gold Certification

3 .

Technical services and ergonomics

4 .

The Furniture Industry Research Association

5 .

Site tours

Introduction to Element



firainternational



element

The recognized leader in Testing,
Inspection and Certification
Services to a diverse range of
industry sectors where failure in
service is not an option

Our purpose



Making tomorrow safer than today

We help our customers make certain that their products, materials, processes and services are safe, compliant and fit for purpose.

#MakingTomorrowSaferThanToday

firainternational

Introduction to FIRA International

firainternational





Take steps to prevent slips, trips and falls

Use the correct tools and equipment for each task

Use all required personal protective equipment

Store, use and dispose of hazardous substances safely

Testing at FIRA International

Howard James, Testing and Technical Manager



firainternational

Testing overview

- FIRA International holds UKAS accreditation to ISO/IEC 17025:2017 General Requirements for the competence of testing and calibration laboratories
- The schedule of accreditation covers of a comprehensive range of testing for furniture and related products
- We conduct testing which simulates real-life use and foreseeable misuse for all types of furniture and related products

Testing scope

- Flammability and physical performance tests
- Safety, strength and durability testing
- Performance tests
- Bespoke testing
- Development of new test methods
- Assessment of instructions and flat pack assembly

What our experts test to

- Regulations
- British Standards (BS)
- European Standards (BS EN)
- International Standards (ISO)
- Other Standards (ANSI-BIFMA)
- Industry Standards (FRQG)
- No relevant standard? We can develop a test procedure for your product

bsi.



firainternational

Why test?

- Comply with regulations (e.g. Furniture & Furnishings (Fire) (Safety) Regulations, the Machinery Directive)
- Demonstrate a product is safe as part of a risk assessment in accordance with the General Product Safety Regulations
- Form part of a due diligence defence in the event of an incident
- Meet client specifications/tenders
- Reduce returns/complaints
- Demonstrate quality

Where do we test?

- FIRA International, Stevenage
- FIRA CMA, Hong Kong
- Element, Mississauga, Toronto, Canada
- Element, St Paul, Minnesota, USA



Materials testing

- Finish performance on worktops, doors and panels
- Adhesion of surfaces and edging
- Environmental testing
- Adhesive testing



Upholstery testing

- Flammability; domestic and contract
- Physical testing of fabrics; strength, abrasion and pilling, colourfastness
- Foam performance
- Cushion performance
- Mattress testing

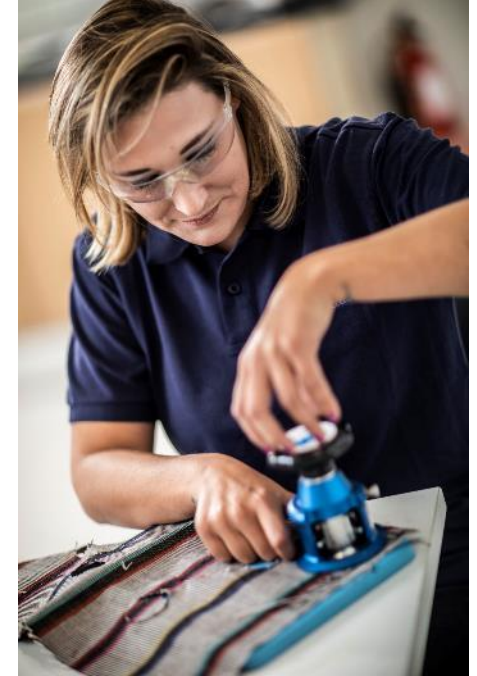

Structural testing

- Safety and durability of complete items of furniture:
 - seating
 - tables and desks
 - storage furniture
 - kitchens
 - beds
 - children's furniture



Further testing

- Balustrades
- Childcare articles
 - cots
 - changing units
 - highchairs
 - safety gates



Equipment sales and in-house testing support

- Furniture testing equipment:
 - Complete labs in Egypt, Singapore, Malaysia, Hong Kong, Philippines
- Manufacturer's in-house testing
- Other FIRA International approved labs include:
 - Howdens
 - FPRDI Testing Laboratories (Philippines)
 - FRIM (Malaysia)



Why test with FIRA International?

- We can trace our origins back over 70 years to 1949, so we're very well established
- Our experts have great in-depth knowledge, and sit on various standards committees
- UKAS Accreditation - ensuring that tests are carried out to the highest standards
- Wide scope of testing
- 'Tested by FIRA' logo – which sends a strong message to consumers and customers
- E-TIC Hub - our testing portal



FIRA Gold Certification

firainternational



Introduction to FIRA Gold

- Quality Certification mark recognised across the furniture industry
- Established 30+ years
- Demonstrates compliance with relevant legislation and levels of standards
- Exclusive to FIRA members
- Scope includes domestic and contract
- Applicable to entire final product, component or installation service



Achieving product certification

- Initial type testing to all applicable standards
- An initial inspection of manufacturing premises
- Review of customer complaints process
- A selected retesting programme
- Annual factory audit



Holders include

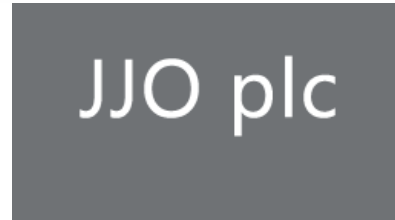

firainternational

Achieving installation certification

- Assessment of Installation Manual
- Encompasses legislation, good working practices and company policies
- Pre-audit visit
- Annual audit of each installation manager



Holders include



Why consider FIRA Gold

- Stand out from competitors
- Provides customer satisfaction and reassurance
- Grow company reputation and brand
- Enjoy new marketing and promotional opportunities
- Be specified for more projects and tenders
- Recognise employees





Technical services



firainternational

Technical Services team

- Dedicated team of experts that provide knowledge-based solutions
- Guidance on changing legislative landscape
- Training in key areas
- Auditing and certification for a range of industry schemes

Key areas

- Product and process improvement
 - Company audits / due diligence assessments
 - Gap analysis
 - Product assessments
- Commercial services
 - Risk assessments
 - Failure analysis
 - Technical expertise
 - Training
 - FIRA Expert

Process improvement – company audits

- FIRA International Gold Certification
- Furniture Industry Sustainability Programme (FISP)
- Compliance Scheme for Fire Performance of Upholstered Furniture
- Manufacturer's Guild Mark (MGM)
- Pre-certification audits
- National Bed Federation (NBF)

FIRA Expert – virtual consultation

- Tailored advice for customer on industry issues
- Typical topics include
 - Environment and sustainability
 - General Product Safety Regulations
 - Flammability
 - REACH

Sustainability training

- Resource Efficiency, Material Transparency
- Circular Economy
- Packaging & Packaging Waste
- Certification
- New for 2022 Carbon Measurement & Towards Carbon Zero

Flammability training

- Flammability Requirements for Beds & Mattresses, across the Domestic & Commercial Sectors
- Understanding Flammability Requirements for the Contract & Office Furniture Sector
- Understanding the Domestic Furniture Regulations & Working to Compliance

REACH training

- Introduction to REACH
- Annex XVII Chemical Restrictions
- Annex XIV Substances of Very High Concern
- Introduction to the change in Regulations post Brexit.
- Product Testing For REACH
- Worldwide Chemical Legislation
- Biocidal Products Regulation
- Chemicals and CSR
- Flame Retardant Chemicals



Ergonomics



firainternational

What is ergonomics?

- A multi-disciplinary approach to achieve a good fit between people and the:
 - Equipment they use
 - Work they do
 - Environment in which they operate

An example

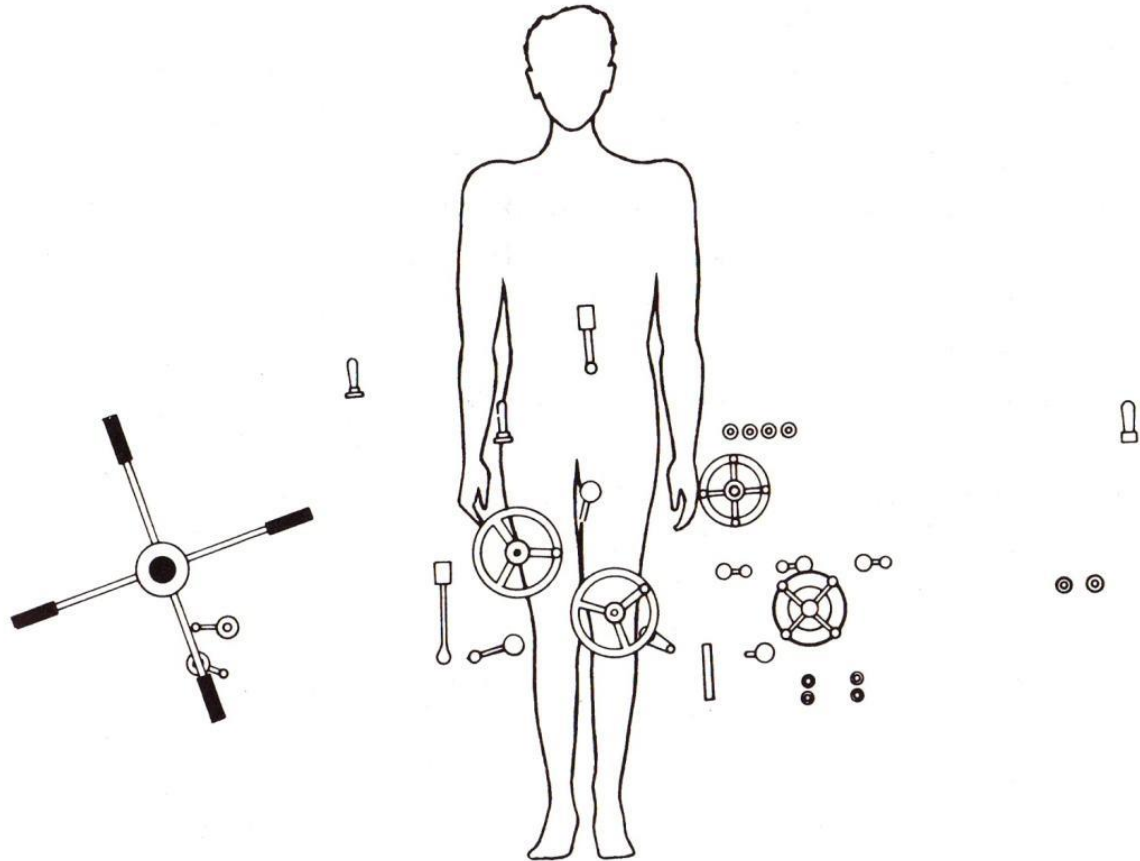

An example

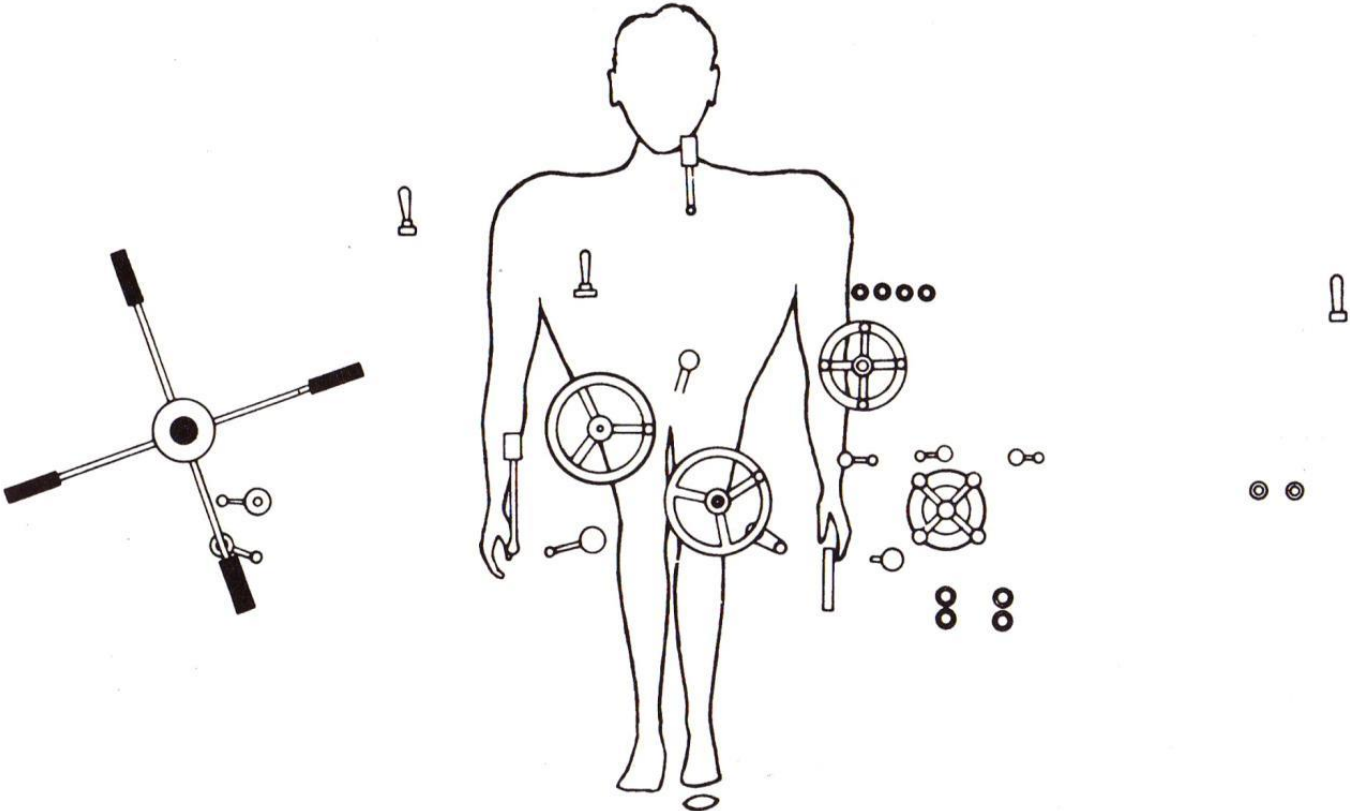

Ergonomics encompasses all places



Schools



Offices



Factories

Size matters?



Activities of ergonomics at FIRA International

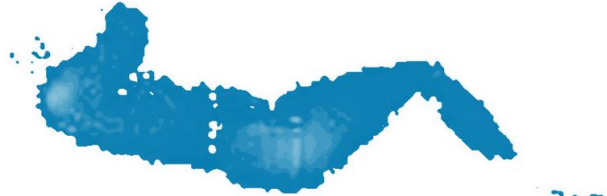
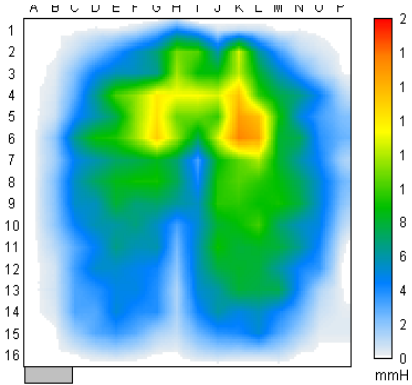
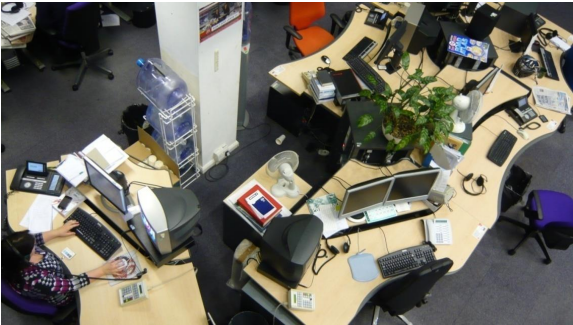
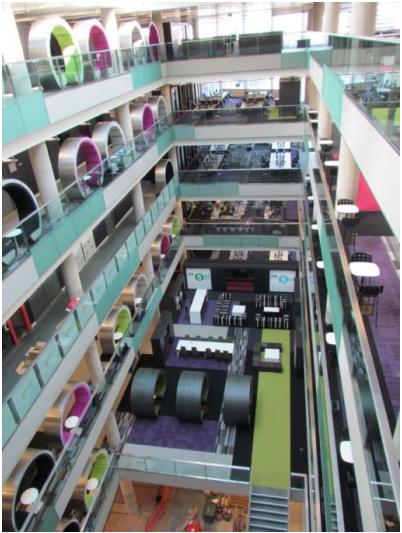

Workplace design and evaluation

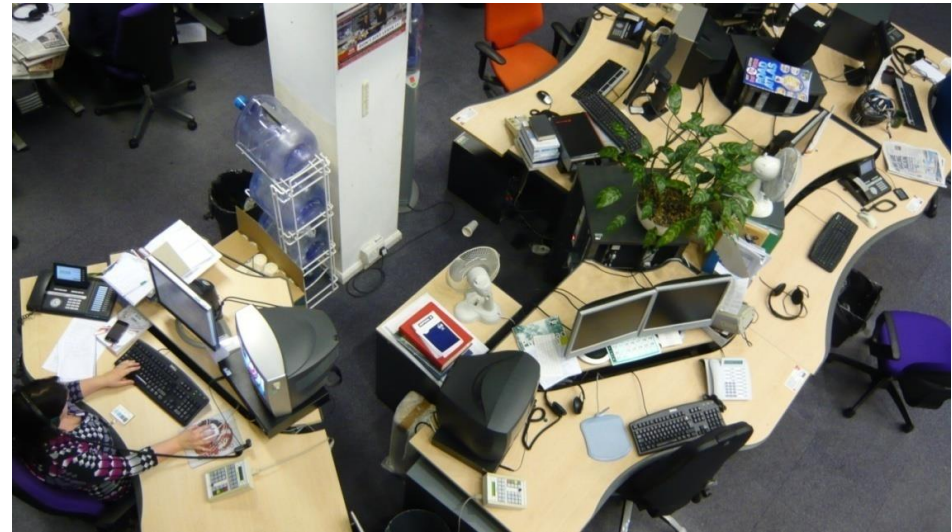

Compliance with regulations

- Compliance with Health & Safety Regulations
 - Display Screen Equipment
 - Manual Handling
- Ergonomics risk assessments and solutions

Risk assessments



Furniture specification development and assessment

- Working with facilities managers and procurement
- Development of technical /ergonomics furniture specification and evaluation of bids
- Furniture selection / user trials

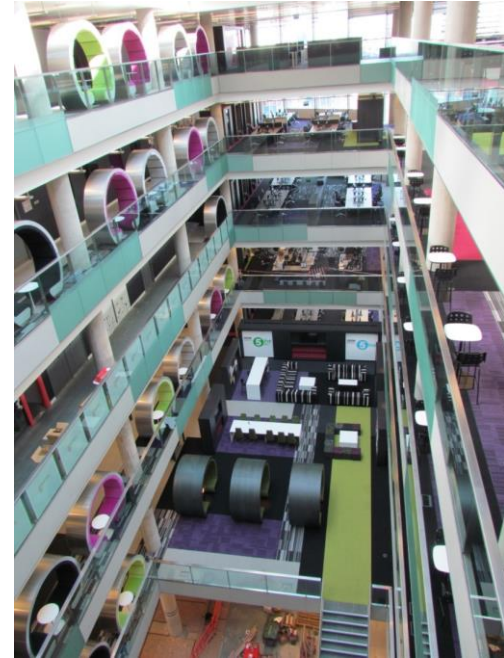

Furniture selection process

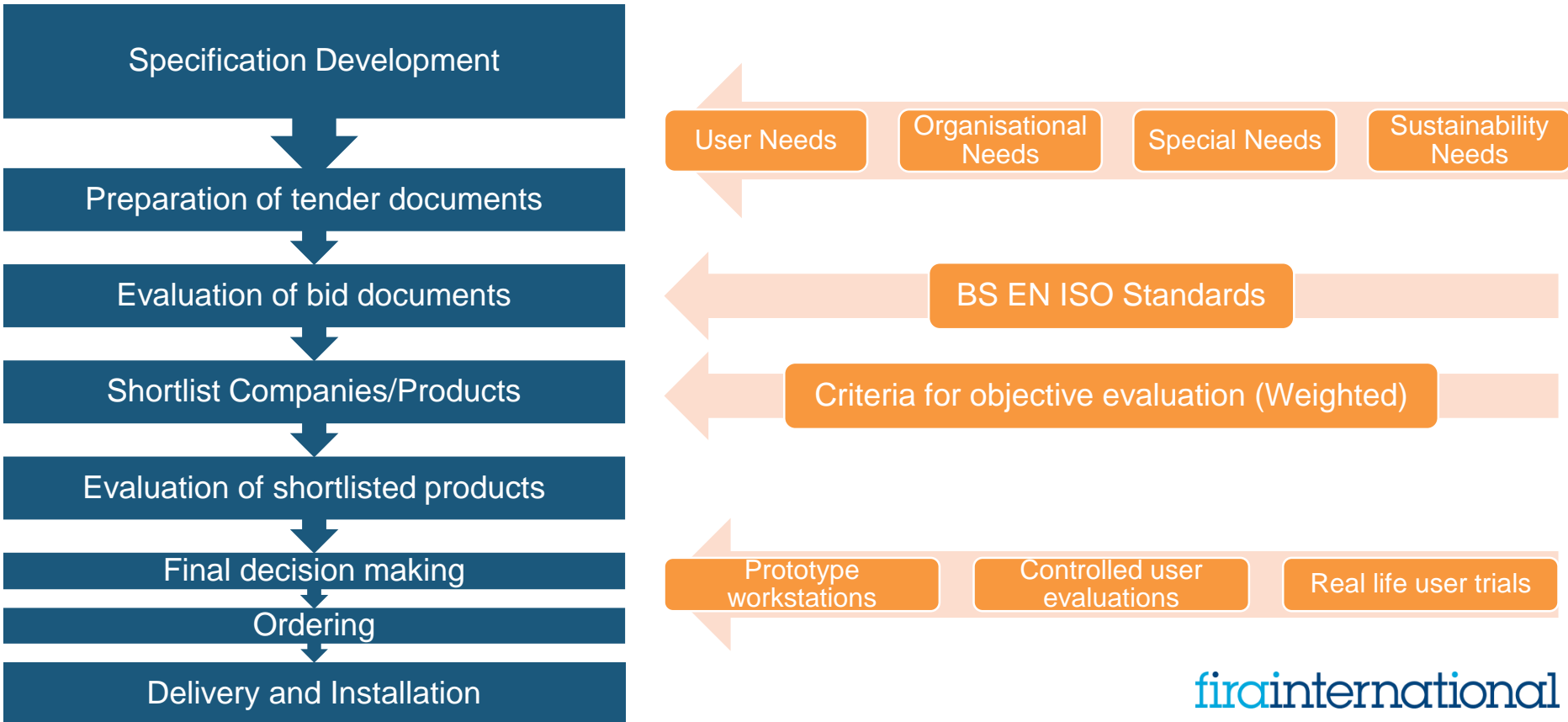

Testing and standards

- Test to existing standards
 - BS EN 1335 – 1
 - BS EN 527 – 1
 - BS EN ISO 9241 – 5
 - BS EN 1023 – 1
 - BS EN 1729 -1
 - NEN, DIN, BIFMA standards etc.
- Develop new tests as required
 - For chair headrests, coat hangers (on chairs)
 - Monitor arms, laptop stands, document holders

Ergonomics testing

- Measured to ensure that they will dimensionally fit the intended population
- Standards:
 - BS EN 1335-1
 - BS EN 527-1
 - BS EN ISO 9241
 - BS ISO 24496

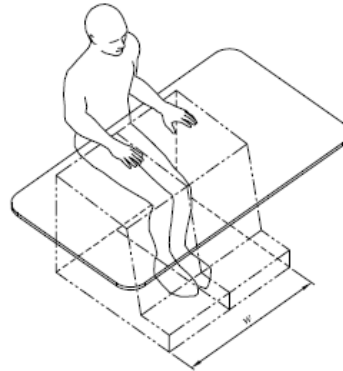
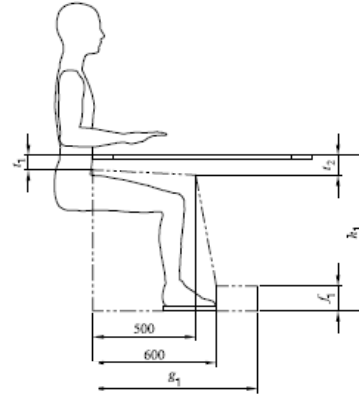

Product evaluations

- Ergonomics evaluations of products:
 - Appraisals
 - Fitness for purpose
 - Risk analysis - assessment
 - Ergonomics Excellence Award

User trials for any product assessment



Mobility scooters



Catering for the aging population



Rise / recliner

Risk assessment / product liability / expert witness



'Ergonomic' products

**As more and more products become 'ergonomic',
there is now a need to differentiate between products
claiming to be ergonomic**

Even though all such products comply with appropriate
ergonomics standards

FIRA Ergonomics Excellence Award

- Launched in order to identify and differentiate those products which excel in ergonomics from those which only meet the minimum requirements of ergonomic standards



FIRA Ergonomics Excellence Award holders



Aeron
Herman Miller



**Quick Stand
Lite**
Humanscale



Freedom
Humanscale



Erich Keller
F-Com Trading Desk



Ergonomic Cafe
GO MOBILE
Laptop Stand
Range



firainternational
ergonomics excellence

firainternational

Pressure mapping for seating

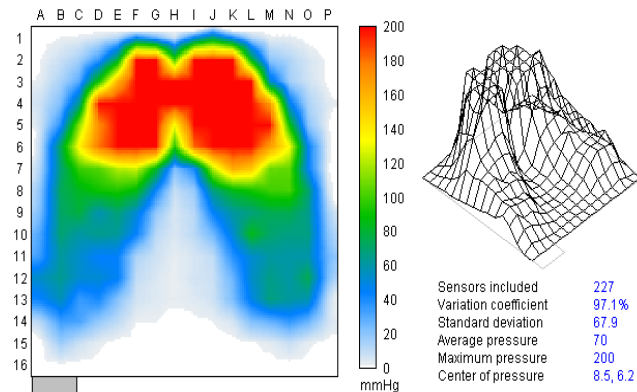
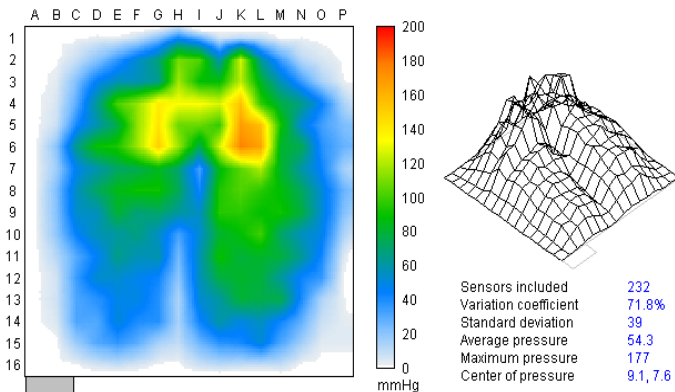
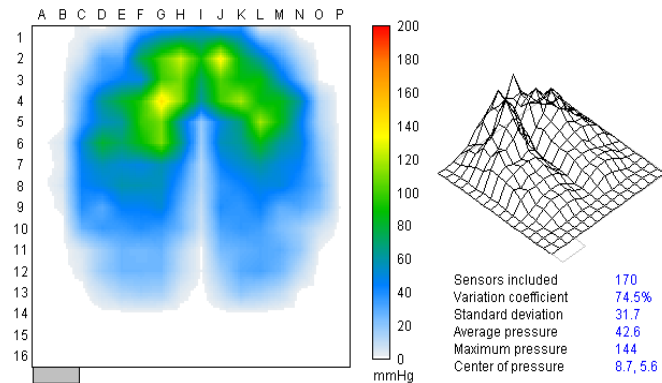
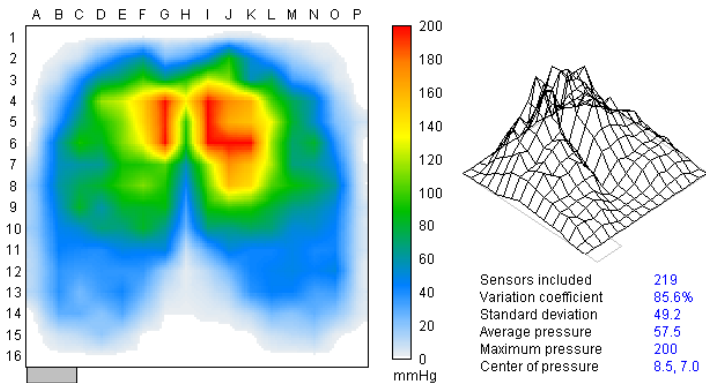

Pressure mapping for beds

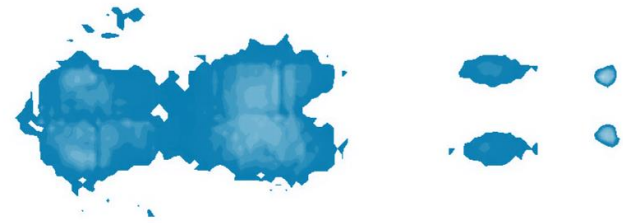

Research at FIRA Ergonomics

- Research
 - 2001: Survey of School children in England
 - Design Guides
 - Bariatric seating and beds
 - Kitchen layout design guide
 - Pressure mapping
- Expert witness service



Standards activities

- Ergonomics
- Educational furniture
- Office furniture
- Domestic/contract furniture
- Kitchen furniture
- Beds/Bunk beds/mattresses



Meet the team

Levent Çaglar

Claire Clark

Hellen Davies

Robin Ghoshal



The Furniture Industry Research Association

firainternational



The Furniture Industry Research Association

- FIRA International are the service provider to the Furniture Industry Research Association
- We are two separate entities
- History that can be traced back to 1949
- Run by the industry for the industry
- Work steered by a Council that meets quarterly
- The Research Association are part of the British Furniture Confederation (BFC) giving members opportunities to feed into Government

The Research Association's role

- Supporting the entire furniture supply chain, across all sectors
- Hundreds of members benefit from access to knowledge, helping to keep them informed and providing guidance on compliance
- Publishing guides on key topics which affect the sector
- Representation on standards committees
- All knowledge available via a login to fira.co.uk

Membership

- Membership is open to all companies within, or with an interest in the furniture market
- Types of membership
 - Full membership: for manufacturers, retailers and major suppliers
 - International membership: for those overseas
 - Associate membership: for research institutes, universities etc.
- Additional membership benefits include discounts on testing and training, and full members receive 'voucher credits' which can be redeemed against services

Work on standards committees

- Important role of the Research Association is representing members on various standards committees
- This ensure members have a voice when new standards are in planning or amendments to standards are in discussion
- Quarterly Standards Update released in March, June, September and December to enable members understand key developments
- Research Association are also involved in the committee looking at possible changes to FFFSR

Recent projects



BUSINESS TEMPLATE

Carbon Footprint Calculator



This carbon footprint calculator enables you to produce a Scope 1+2 Carbon Footprint for your operations. A Scope 1+2 Carbon Footprint covers emissions that arise directly from sources that are owned or controlled by your business, together with the emissions generated by purchased.



fira.co.uk



Biocidal Products Regulation guide



Published by

FIRA International Limited
on behalf of the Furniture Industry Research Association
Maxwell Road, Stevenage, Hertfordshire, SG1 2EW, United Kingdom
Tel: +44(0)1438 777 700, Email: info@fira.co.uk

© FIRA International Limited 2019



UKCA & UKNI marking guidance

Great Britain and Northern Ireland Conformity Assessment Marks



August 2021

Prepared by

FIRA International Limited
on behalf of the Furniture Industry Research Association
Unit 3, Cockerell Close, Stevenage, Hertfordshire, SG1 2NB, United Kingdom
Tel: +44(0)1438 777 700, Email: info@fira.co.uk



Recent projects

FIRA
Furniture Industry Research Association

Horizon Scanning - New Hardline and Softline Materials



February 2021
Prepared by
FIRA International Limited
on behalf of the Furniture Industry Research Association
Maxwell Road, Stevenage, Hertfordshire, SG1 2EW, United Kingdom
Tel: +44(0)1438 777 700, Email: info@fira.co.uk

© FIRA International Limited 2021

FIRA
Furniture Industry Research Association

Packaging and Sustainability - Guide to Alternatives



April 2021
Prepared by
FIRA International Limited
on behalf of the Furniture Industry Research Association
Maxwell Road, Stevenage, Hertfordshire, SG1 2EW, United Kingdom
Tel: +44(0)1438 777 700, Email: info@fira.co.uk

© FIRA International Limited 2021

Recent projects

FIRA
Furniture Industry Research Association

Employees' guide to ergonomic home working



User's guide to the ergonomics of working with laptops or computers at home

June 2020

Prepared by
FIRA International Limited
on behalf of the Furniture Industry Research Association
Unit 3, Cockerel Close, Stevenage, Hertfordshire, SG1 2NB, United Kingdom
Tel: +44(0)1438 777 700 Email: info@fira.co.uk

FIRA
Furniture Industry Research Association

Employers' guide to ergonomic home working



Ergonomics guide: employers' responsibilities for the ergonomics of home working

January 2021

Prepared by
FIRA International Limited
on behalf of the Furniture Industry Research Association
Maxwell Road, Stevenage, Hertfordshire, SG1 2EW, United Kingdom
Tel: +44(0)1438 777 700
Email: info@fira.co.uk

FIRA
Furniture Industry Research Association

Home Office Buying Guide



October 2021

Prepared by
FIRA International Limited
on behalf of the Furniture Industry Research Association
Maxwell Road, Stevenage, Hertfordshire, SG1 2EW, United Kingdom
Tel: +44(0)1438 777 700, Email: info@fira.co.uk



Thank you

