

Installation Guide

Model: Axiom 12



latham
The Pool Company™

 **Made in U.S.A.** 

Step 1. PLANNING FOR THE INSTALLATION

This list is not intended to be all inclusive but a general guideline.

RECOMMENDED TOOLS

1. Hammer
2. Neon nylon string 2 rolls
3. Yard marking spray paint
4. Strap kit (four 20' straps, one 33' strap, one 35' strap, four 2" to 3" shackles [U bolts], one large (4") shackle)
5. Two 2" ratchet straps
6. Laser transit/level
7. 2" duct tape
8. 2 – 50' ropes
9. Sharpie markers
10. A roll of paper towels
11. Shop Rags
12. Bi-metal Hole saws, 2-3/8", 1-1/2", 3", and 5" with centering bit
13. Reciprocating saw (Sawzall) or jig saw with extra 6" bi metal blades
14. Cordless drill (with multiple batteries charged)
15. A drill bit set (with multiple ¼" bits)
16. Leather Gloves
17. Caulk gun. Optional: auto caulk gun
18. 1 – 35' rigid tape measure
19. 1 – 100' measuring tape
20. Utility Knife
21. PVC cutters that will cut 2" pipe
22. Phillips head screw driver (#2 to tighten skimmer screws)
23. Pen and grade work sheet
24. A box of 2" screws
25. A box of 3" screws
26. Pipe wrench
27. A 4" handheld grinder (for squaring up the skimmer hole and/or flattening the back side of the shell for return fittings and lights – is a must-have in case you accidentally cut through a hook or core location)
28. Shovels, level rake (no teeth/tines) , picks
29. Wheelbarrow
30. Bottle jack
31. Short 2x4's and short 4x6 boards
32. Crane
33. Skid steer - track driven preferred
34. Excavator
35. Dump truck
36. Safety fencing
37. Hoses (2)
38. Spreader Beam/Bar
- w1.4 Wire Mesh
- d. Rebar ties with pig tail

6. Pool Equipment
 - a. Pump
 - b. Filter
 - c. Chlorinator (if required)
 - d. Heater (if required)
 - e. Automation (if required)
 - f. Lighting (with transformer)
 - g. Handrail and/or ladder with escutcheons (and concrete anchors)
 - h. Equipment pad or Portland cement and form boards
7. Tile Kit
 - a. Waterline tile, step/seal inlays, inlaid mosaic tiles
 - b. Adhesive and grout for tile with scrubber sponges
 - c. Tile float
 - d. Extra tubes of silicon adhesive/sealant
8. ½ inch crushed, washed clean angular stone or sand free of foreign material (for pool base and backfill)
9. Forms for concrete
10. Cantilever deck forms (Stegmier / Mortex) (if required)
11. Extra ties for Forms
12. Wood stakes
13. Materials for brick or stone work
14. Materials for concrete deck
15. Materials for pavers

CONSUMABLE MATERIALS LIST

1. 2 – 4' 2x4's
2. 1 – 10' 2x4's
3. 2 – 16' 2x4's
4. Plumbing
 - a. PVC Pipe and Fittings (that comply to FED, State, and Local codes)
 - b. PVC Cleaner and Glue
5. Electrical
 - a. Electrical conduit (pipe, elbows, unions)
 - b. Wire and Hardware (that comply to FED, State, and Local codes)
 - c. Rebar (42 three foot [3'] sticks) or 6"x6"W1.4 x

SITE PREPARATION AND PLANNING

In planning for the installation of a new Latham pool, there are many important considerations that must be evaluated in order to achieve a functional, long-lasting and aesthetic addition to a home. When choosing a location, consider the following:

1. Grade: Pools and decks are normally constructed on level ground. Extreme variations in grade should be resolved before the excavation of the pool begins. A relatively level and flat location is preferred so time and effort are not wasted on radical fluctuations in grade.
2. Excavation Equipment Access and Pool Delivery: Determine the most efficient route for equipment to enter and access the site. Also keep in mind that a well planned route can save time and money by enabling multiple pieces of equipment to work in unison. For example: Coordinate the delivery of the pool with the completion of the excavation and preparation of the hole. Use of a crane with four (4) 20-foot straps is recommended for the process of setting the pool shell in the excavated site. However, if a track excavator was used to prepare the site, in some cases it may also be utilized to unload and set the pool. Contact Latham for specific guidelines for setting pools with excavator equipment. Finally, consider the placement of the equipment. If possible, position the pool equipment so the pool shell can be unloaded and placed directly into the excavation without risking damage to the equipment.
3. Underground Utilities: Check with local authorities in advance for the locations of underground water, gas, power and sewer lines.
4. Overhead Power Lines.
5. Local Building Codes: Determine the setbacks from property lines, easements, house footings, etc.
6. Underground Water Conditions.
7. Water Drainage: Water should always drain away from the pool. Failure to keep ground water away from the exterior of the pool may result in damage to the pool that is not covered under warranty.
8. Local Fencing Codes.
9. Location of Pool Equipment.
10. Electrical Run for Pool Equipment.
11. Exposure to Sunlight.
12. Surrounding Foliage.
13. View from Residence.

LATHAM POOL PRODUCTS, INC. ("LATHAM") PROVIDES THIS INSTALLATION GUIDE IN ORDER TO ADVISE DEALER/BUILDERS OF LATHAM'S BEST PRACTICES RELATED TO INSTALLATION. THE INSTRUCTIONS AND RECOMMENDATIONS CONTAINED IN THIS GUIDE ARE ENTIRELY ADVISORY. INSTALLATION DECISIONS REMAIN WITHIN THE SOLE DISCRETION AND JUDGMENT OF THE DEALER/BUILDER AT ALL TIMES. WHERE THIS MANUAL STATES SPECIFIC DIRECTIONS OR REQUIREMENTS, SUCH DIRECTIONS AND REQUIREMENTS COMMUNICATE TO THE DEALER/BUILDER WHAT IS NECESSARY OR REQUIRED IF THE DEALER/BUILDER CHOOSES TO COMPLY WITH LATHAM'S BEST PRACTICES RELATED TO INSTALLATION. HOWEVER, DEALER/BUILDERS SHOULD BE AWARE THAT ANY WARRANTY CLAIM WHICH RESULTS FROM THE FAILURE TO COMPLY WITH THIS INSTALLATION GUIDE MAY BE EXCLUDED FROM WARRANTY COVERAGE BY THE EXPRESS LANGUAGE OF THE APPLICABLE WARRANTY.

NOTICE:

Failure to read and follow specific instructions contained in this manual may void your pool warranty.

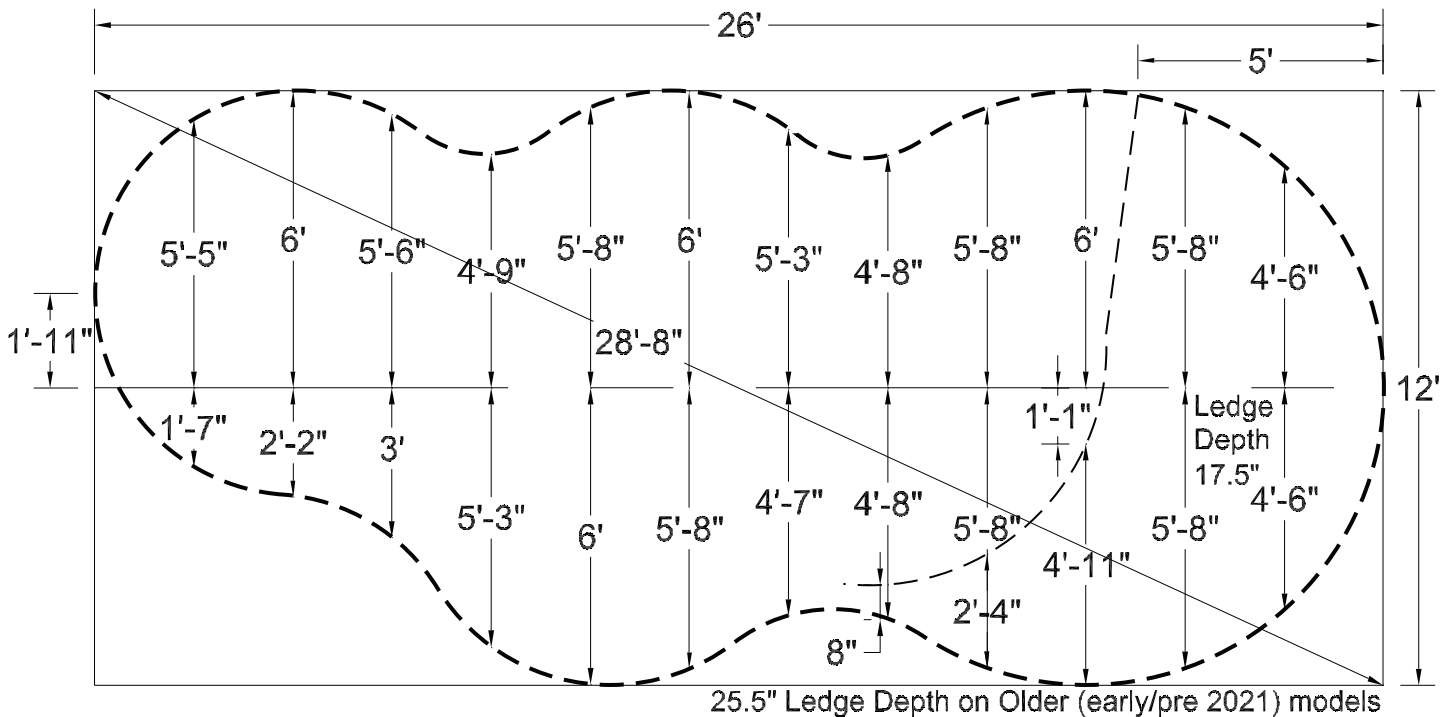
Step 2. POOL LAYOUT

When laying out the pool, note that the dimensions are to the outside edge of the pool beam. Most permit plans are measured to the water's edge. The beam of a Latham fiberglass pool is approximately 4" to 10" on all sides. Therefore, there is generally a difference of 8" to 20" between the length and width dimensions in the installation guide and those of the permit plans in most cases (see the Latham fiberglass pool specification document for inside and outside dimensions for each model). Overall length and width measurements may vary up to 3%. Depending on the customer and the local building inspector, this fact can be a critical consideration. Distances between the water's edge to most property lines, electrical lines, and other structures such as houses, garages, sheds and patios must be within plan specifications.

Start by laying out the pool template or with a 12' wide by 26' long rectangle with diagonal measurements of 28'-8". Next, layout the center point, making sure the center lines are at 90 degrees. Stake each point around the perimeter of the pool as shown in Figure 1. Connect each stake with string. Denote the location of the skimmer with a 2'x2' box outside of the pool layout. Use spray paint to follow the contour of the string. The outline will be the shape of the outside dimensions of the pool shell. Remove the string and stakes, leaving only the outline of the pool. Be sure to mark tanning ledge location, if any.

NOTE: Latham Pool Products offers yard templates for each pool model offered. The yard templates are reusable and are the dimensions of the shell. If using a yard template, simply lay the template out in the yard where the pool is to be set and paint a line on the edge of the template. Check price and availability. The template order form can be found in the Dealer Manual.

Figure 1 - Excavation Dimensions



Step 3. ELEVATION

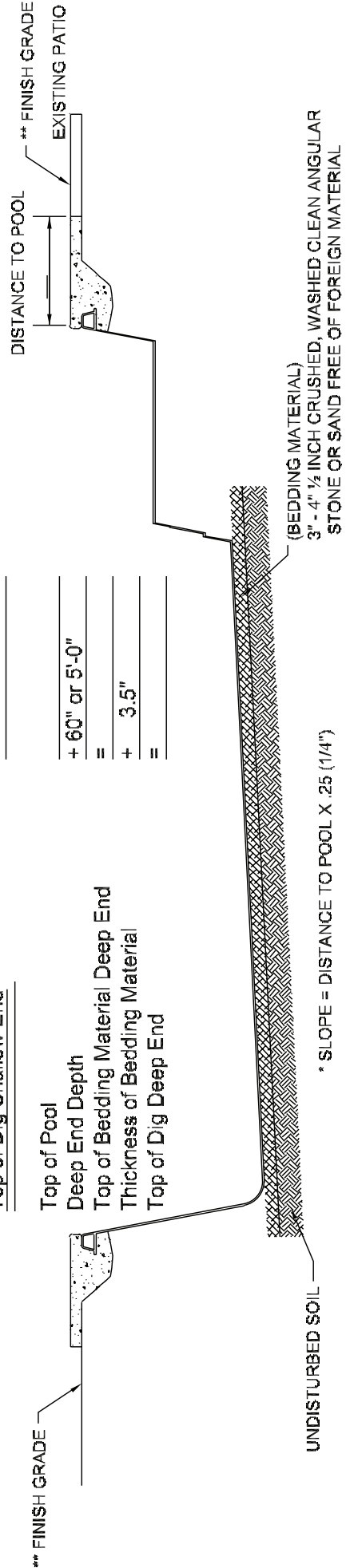
Elevation and grade of the pool area are two of the most often overlooked or miscalculated variables in the installation process. While considering all the variables concerning elevation and grade, always remember that you want water to run away from the pool. Before excavation, use the provided Form 1 – INSTALLATION PLANNING GUIDE to calculate all critical measurements.

Check the four corners of the pool layout with the aid of a laser level or a sight level to determine the highest corner. This corner will be used in planning the elevation of the pool. In a typical installation, the elevation of the pool should be 4-6 inches above the highest point of the existing grade around the pool. However, careful consideration should be given to pool type, size and drainage of the future pool deck, as well as the elevation of the surrounding landscape and existing structures, patios and sidewalks.

INSTALLATION PLANNING GUIDE

Job: _____ Pool: CRUM Date: _____

Finish Grade	_____
* Slope	_____
Top of Concrete at Pool	_____
Thickness of Concrete	+ 3.5"
Top of Pool	_____
Shallow End Depth	+ 49" or 4'-1"
Top of Bedding Material Shallow End	_____
Thickness of Bedding Material	+ 3.5"
Top of Dig Shallow End	_____
Top of Pool	_____
Deep End Depth	+ 60" or 5'-0"
Top of Bedding Material Deep End	_____
Thickness of Bedding Material	+ 3.5"
Top of Dig Deep End	_____



* SLOPE = DISTANCE TO POOL X .25 (1/4")

** IF POOL IS INDEPENDENT OF ANY EXISTING STRUCTURES OR PATIOS, FINISH GRADE IS TO BE 3 1/2" BELOW EDGE OF POOL DECK.

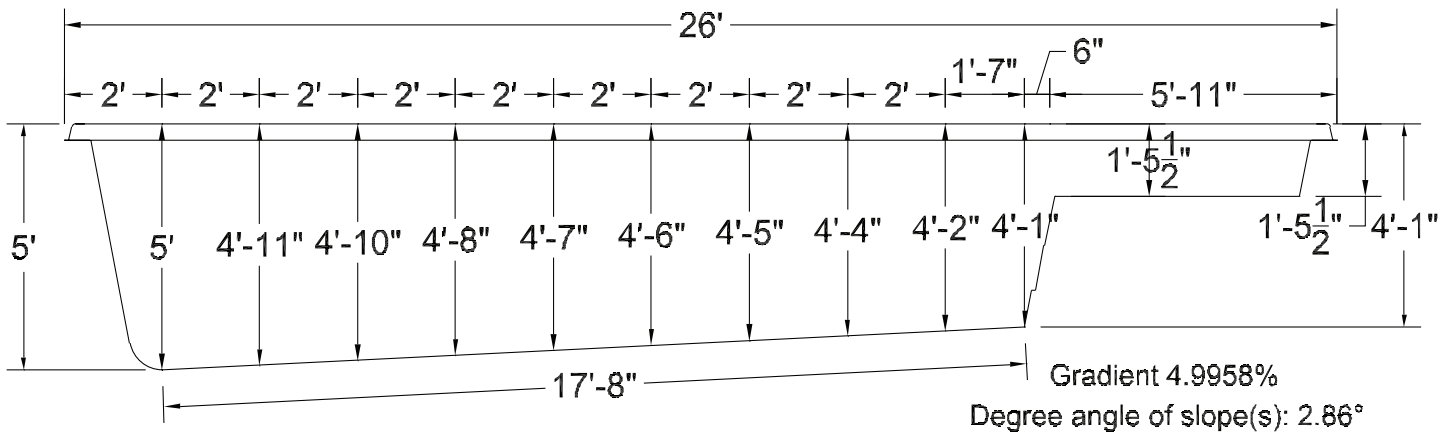
Step 4. EXCAVATION

Correct excavation of the pool is very important. A hole that is too small can mean hours of picking and shoveling by hand. A hole that is too large will require extra recommended backfill material, which if not dealt with properly, can result in settling or bulging of the pool.

The excavation should be dug very close to the pool size with a minimum disturbance to the unexcavated soil which will support the pool. The clearance is approximately 6" on the sides and 6" on the ends (see Figure 2). The use of an excavation bucket with a grading blade attached will cause less disturbance to the soil than an excavation bucket with teeth.

NOTE: THE MEASUREMENTS PROVIDED BELOW ENABLE THE BUILDER TO SET THE SHELL WITHIN A FEW INCHES OF LEVEL. LIFT THE SHELL AND ADJUST THE BASE AS NECESSARY TO ACHIEVE LEVELNESS OF THE SHELL WITHIN THE INDUSTRY STANDARD.

Figure 2 - Pool Shell Depth Dimensions



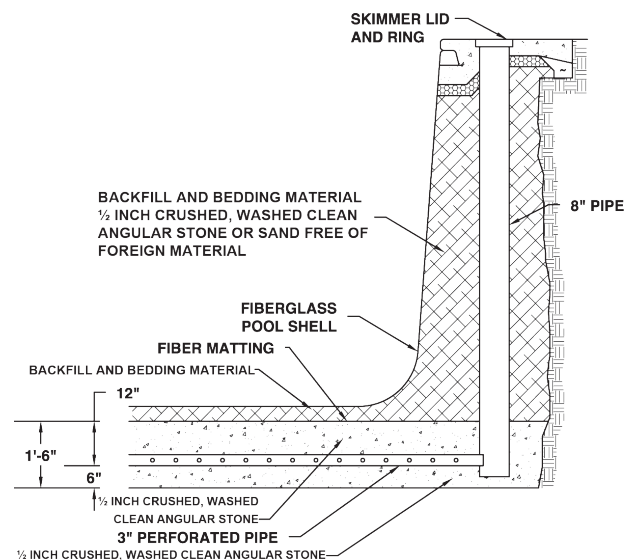
The depth of the excavation is determined with the use of a transit level and grade pole. The bottom of the excavation is over dug approximately 4". This size pool will require approximately 20 to 25 yards of 1/2 inch crushed, washed clean angular stone or sand free of foreign material for backfill (more may be required if the excavation is significantly over-dug).

The excavation should be 13' by 27', with a total depth of approximately 4'-5" (shallow end) to approximately 5'-4" (deep end) from the desired elevation of the pool. It can be helpful to give yourself extra room the first 6" in width and 12" in length of the hole, to get past the coping, and allow space for the skimmer and bottom suction fittings (if any). Also, keep in mind that the wall of our pools are tapered, usually 1" in for every 12" in depth. A place for the skimmer must also be dug in the side of the excavation wall. The skimmer cutout should be 2' by 2' and 3' deep. See Figure 1 for placement. Pools with tanning ledges require the tanning ledge area excavated to the depth stated in Fig. 1 plus 4" for bedding material.

Never use excavated material as fill or backfill in the hole; the material will settle. We suggest 1/2 inch crushed, washed clean angular stone or sand free of foreign material compacted thoroughly (a plate tamper is recommended for the pool base). The fill material used for the pool base must also be used to backfill around the sides of the pool shell. In the case of significant over excavation on the sides of the pool or in seasonal high water or poor drainage areas, you may want to mix 10% Portland cement with the backfill for stabilization.

In order to be in compliance with Latham's recommended guidelines Latham requires that a permanent sump pipe (see Figure 3) be installed on all pools. A gravity fed "daylight drain" is preferred to a permanent sump pipe installation, if applicable. The purpose of the sump pipe installation (or daylight drain) is to provide a means of checking for groundwater around the pool and allow for dewatering the site prior to any work on the pool that requires lowering the water level within the pool shell, thus minimizing potentially high hydrostatic pressure. Latham recommends the installation of a permanent sump pump in areas with a high water table and/or significant ground water. Latham suggests digging an 18" x 8' x 18" trench across the deep end of the excavation. Six inches of 1/2" clean gravel should be placed in the bottom of the trench. A section of 3" perforated PVC pipe is placed on the rock base and connected to a vertical stand of 8" PVC pipe running to the surface of the excavation. Cover the new sump line with landscaping fabric. The 8" PVC riser pipe should be trimmed with a skimmer ring and lid for aesthetics and safety. After the connection has been made to the vertical stand of 8" PVC, finish covering the 3" perforated PVC pipe with 1/2" to 1" clean gravel to the bottom of the excavation (see Figure 3). The bottom of the excavation is now ready for approximately 4" of base material. Be sure to secure the skimmer lid (with screws) to the ring attached to the top of the vertical 8" PVC.

Figure 3 - Sump Pipe Installation

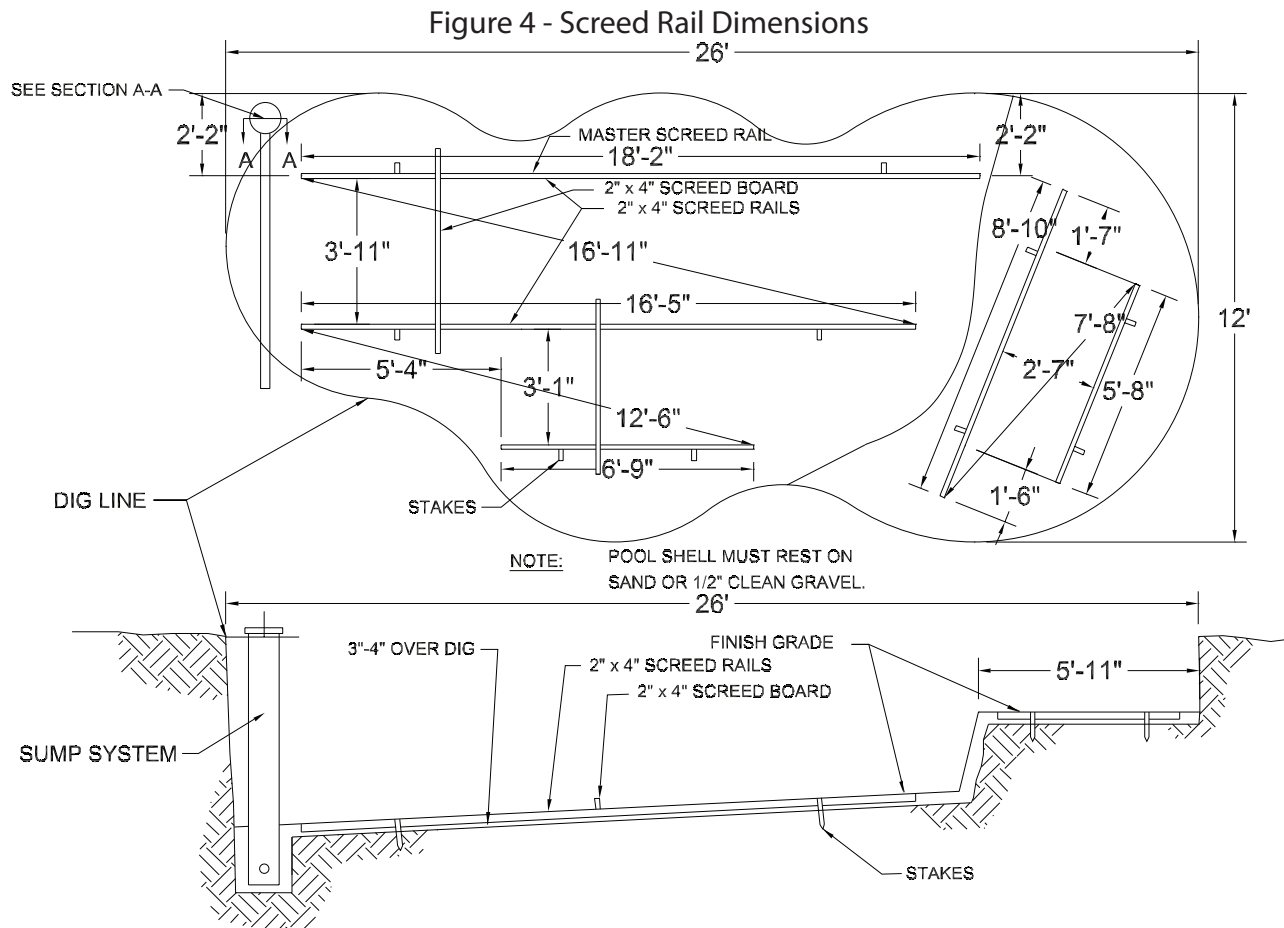


Step 5. PREPARATION OF THE BOTTOM SURFACE OF THE EXCAVATION

The preparation of the excavation bottom is critical so the pool will fit properly. Thorough preparation will reduce settling, stress cracks and a minimize the amount of time will be spent setting and leveling the pool.

First, install the 2" x 4" master screed rail(s) length wise in the excavation, using wood or metal stakes (See Figure 4). Make sure the diagonal measurement is exact to insure that the bottom is square. Adjust the master screed rail(s) to the appropriate height using a transit level (See Figure 2). Next, install the remaining screed rail(s) parallel to the master screed rail(s) using the offset dimensions as shown in Figure 4 and making sure that they are aligned to the Master screed rail(s) to insure that the bottom is square. Next, spread a layer of fill material approximately 4" deep evenly over the bottom of the excavation. Rake the fill material flat to the top of the screed rails (See Figure 3). Compaction of the fill material is generally achieved by screeding it into place, but depths of greater than 4" will require use of a plate tamper. Rake and compact the area until a stable base for the shell is achieved. Screed the bottom of the excavation, filling any low spots as you go. Remove the screed rails and fill in the voids with fill material, being careful not to disturb the fill.

NOTE: THE MEASUREMENTS PROVIDED BELOW ENABLE THE BUILDER TO SET THE SHELL WITHIN A FEW INCHES OF LEVEL. LIFT THE SHELL AND ADJUST THE BASE AS NECESSARY TO ACHIEVE LEVELNESS OF THE SHELL WITHIN THE INDUSTRY STANDARD.



Step 6. SETTING THE POOL

Upon arrival/delivery of your pool shell, be sure to inspect the pool for damage that may have occurred during transportation and for conformity to order specifications. The recommended method of setting the pool shell is by making use of a crane or boom truck. A track-mounted excavator can be used to lower the pool into the excavation, but directions should be obtained from Latham prior to setting the shell. Please note that Latham recommends lifting all pool models over 12' wide with a spreader bar and 20' lifting straps. Once the pool is set in the excavation, the pool should be checked for level and the bottom should be walked over to detect any voids in the fill material that might be present.

The pool is then lifted and reset as many times as necessary to achieve a "good fit." A good fit is realized by raking the surface of the fill material in order to see where the pool's perimeter is touching (footprint) and by walking around on the inside of the pool to detect low spots. It is normal to feel a slight void under the center of the pool, but walking in the pool should cause the floor to rest on the bed of fill material. The pool shell will conform to the base material under the weight of the water. It is important to make certain that the bottom, perimeter, and all transition points are sitting firmly upon the bed of fill material. The pool can be separated from the lifting equipment when the entire perimeter of the pool (including all transitions) is level within the industry guidelines.

A properly prepared hole should not require the filling of large voids beneath the pool. Blindly adding fill material beneath a pool can cause more harm than good. It is important that any adjustments to the pool's elevation be made before water is added. If the hole was properly prepared, nothing more than a few minor adjustments should be needed.

LIFTS SHOULD BE PERFORMED IN COMPLIANCE WITH ALL APPLICABLE STANDARDS SUCH AS OSHA AND ASME. SPECIFIC STANDARDS THAT MAY BE APPLICABLE ARE LISTED BELOW. THIS IS NOT AN ALL-INCLUSIVE LIST AND OTHER REGULATIONS WHICH MAY APPLY DEPENDING HOW LIFT IS PERFORMED AND EQUIPMENT USED.
 ASME B30.5 OSHA 29 CFR 1910.133 OSHA 29 CFR 1910.179 OSHA 29 CFR 1910.180 OSHA 29 CFR 1926.753

IT IS THE RECIPIENT'S RESPONSIBILITY TO PROPERLY ASSESS THE SITUATION AND ACCOUNT FOR VARIABLES SUCH AS, BUT NOT LIMITED TO WEATHER, EQUIPMENT CONDITION, LOCAL REGULATIONS, ETC. BEFORE OFFLOADING CAN OCCUR. ANY DAMAGE RESULTING FROM THE LIFTING OF THE POOL SHELL IS THE RECIPIENT'S RESPONSIBILITY TO BEAR

Step 7. WATER AND BACKFILL

As backfill material is initially placed around the pool shell, care should be taken to ensure that the wall-floor and step-floor radiuses are tightly packed with fill material, this process is referred to as "locking in" the shell. Once the pool shell is "locked in," the fill/backfill process can continue. It is very important that the radiuses of the pool are properly compacted. Poorly packed radiuses can result in hairline cracks and/or structural cracks due to deflection. Be sure to backfill slowly and thoroughly.

Begin by filling the pool with 12" of water (measured at the deep end of the pool) and then while continuing to fill with water, maintain the level of the backfill material to be approximately 6" below the level of the water. As the water approaches the shallow end, pay particular attention to all the unsupported areas of the pool. Steps and benches tend to flex, so slight adjustments may need to be made with the leveringing device. Be sure you wait until a sufficient amount of water surrounds the area (usually 12") to keep the rest of the pool in place, or you may raise more than you intend. The walls of the pool may deflect inward if too much backfill has preceded the water in the pool, or outward if too much water precedes the backfill. If deflection does occur during the installation, the only remedy is to dig that area out and proceed correctly. A string line is very useful in determining the straightness of the pool walls during the backfilling process.

To mitigate the stress under steps, tanning ledges, and some seats potentially induced on the pool shell as a result of backfill settling, Latham recommends either a shallow dig under large steps, tanning ledges, and some seats (Figure 6) or in the event of an over-dig, the installation of concrete masonry unit (CMU) piers placed under the steps, integral tanning ledges and/or swim outs, and some seats may be needed (Figure 7).

Figure 5 - Backfill Detail

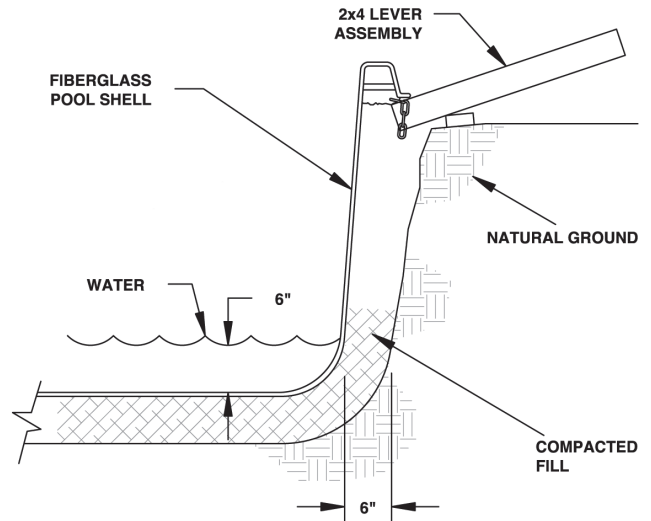


Figure 6 - Minimal Dig Stair Detail

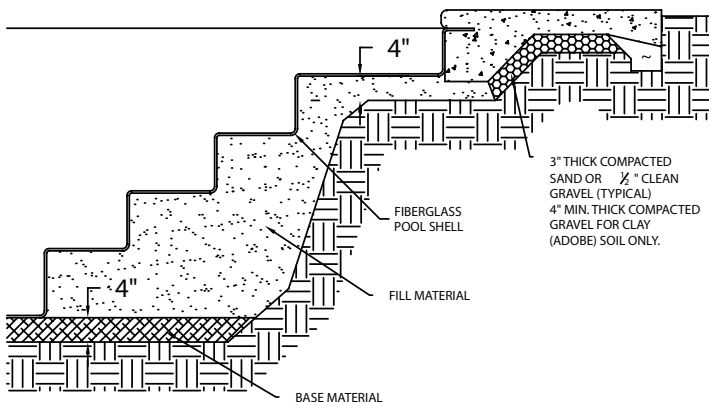
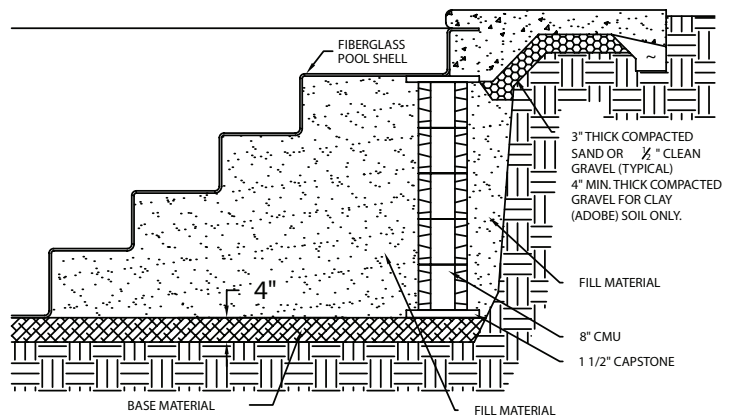


Figure 7 - CMU Pier Stair Detail



Blocking the steps is performed after the pool shell has been set within level and water reaches the tread of the next to last step tread (2nd from floor). When installing CMU piers, start by placing a 1-1/2" capstone block on the base material. On top of the capstone block, stack CMU's (cinder blocks) until they reach a point just under the outermost edge of the top step, tanning ledge or beam of the shell. Since the step area of the pool shell is often lower than the rest of the shell, jack the step package up using a bottle jack and a section of 2" x 6" lumber under the outside radius of the top step (where the top tread meets the top riser). Jack the steps to be level with the rest of the beam of the shell. Shim the gap between the top CMU and the bottom of the tread/riser radius with another capstone block and/or 1/4" concrete backer board. When the bottle jack is released, the pool shell should be level within industry guidelines. Bottle jacks should be removed from the job site once the piers are in place. Do not leave bottle jacks or organic material, such as wood under the pool shell for support. Properly placed piers should be 1/2 under the step of the shell, with the remaining portion of the top block/shim remaining outside the step/riser tread (See Figure 7 for detailed drawing of properly placed piers). Do not place piers completely under the top step or tanning ledge (swimout) as stress will be transferred to the radius between the horizontal and vertical surfaces, resulting in stress fractures.

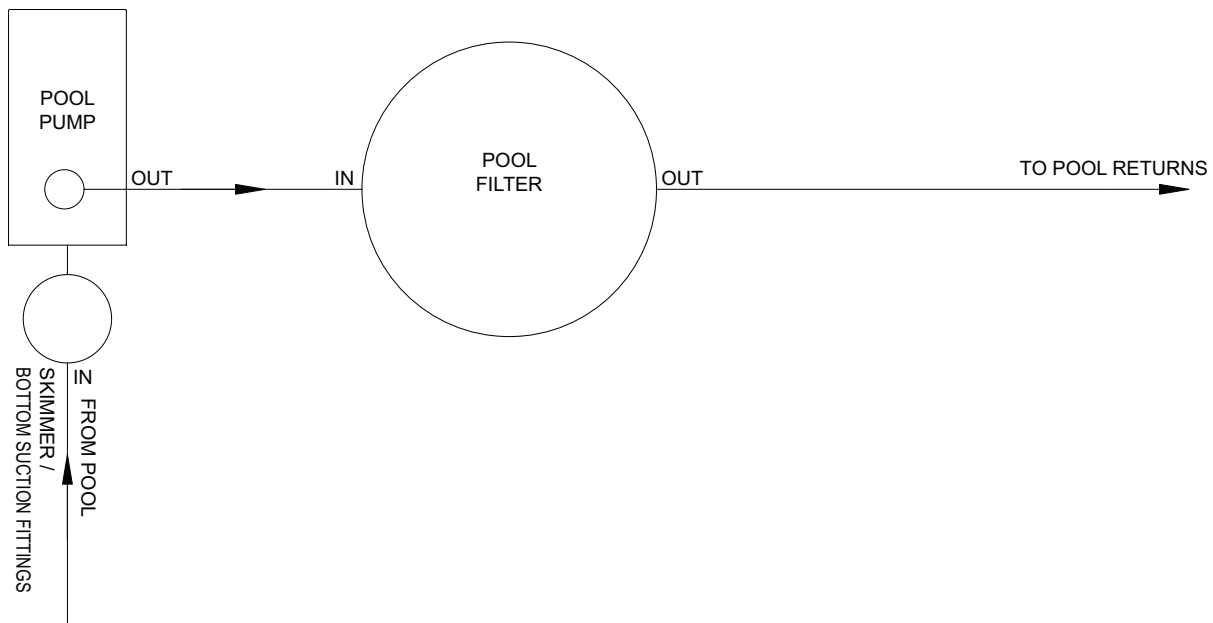
Step 8. PLUMBING

A basic swimming pool circulation system is relatively simple in operation. Water in the pool is drawn through the skimmer to the pump, which pushes it through the filter and back to the pool via the returns. See Figure 8 for a basic filtering system diagram. More advanced filtering systems may include sanitizers, jets, blowers, automatic pool cleaners, etc. Latham recommends the use of 2", schedule 40 PVC plumbing on most pools. The plumbing system must be designed to comply with ANSI/APSP-7 STANDARD FOR SUCTION ENTRAPMENT AVOIDANCE IN POOLS AND SPAS (latest revision). Visually inspect and pressure test all plumbing installed at the factory upon the delivery of the pool and during the backfill process.

Latham Pool Products suggests placing the equipment slightly above the elevation of the pool. If the equipment is placed below the water level, check valves or shut off valves must be installed to prevent accidental siphoning of the pool. The equipment becomes less efficient the greater the distance away from the pool. Check all connections for leaks and proper circulation before covering them. Local building codes may require pressure testing of the plumbing system before the installation is complete.

For alternative recirculation systems refer to the Latham Fiberglass engineering sheets

Figure 8 - Basic Filtering System



Step 9. ELECTRICAL

If the installer or homeowner is not qualified to do electrical work, an licensed electrician should be hired and a building official should inspect the work. All electrical work should be done to National Electric Code specifications and any local codes. Latham will not be held responsible for any electrical work.

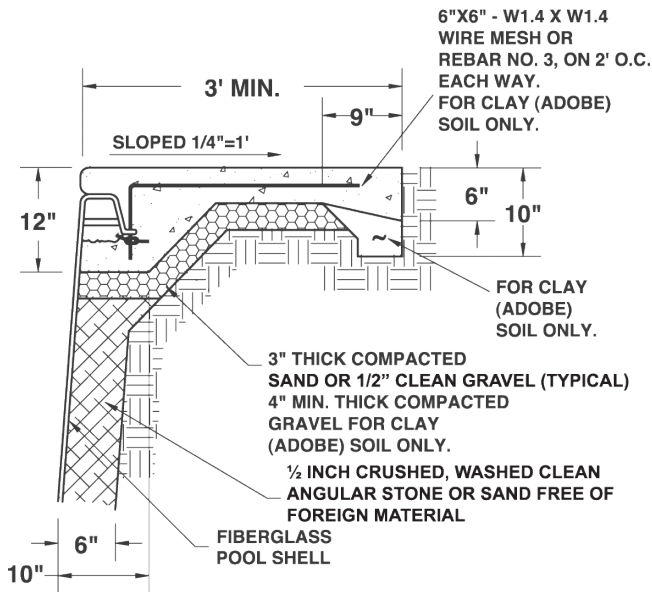
Step 10. POURING CONCRETE

A standard cantilevered deck, as shown in Figure 9, requires that forms be placed on the inside perimeter of the pool. These forms are attached to the pool beam using double-sided tape. The forms are then held in place using supplied wire ties and screws. Cantilever forms are typically installed on the same day of the concrete pour. The backfill should be removed from the top 8 inches around the pool perimeter to a width of approximately 10 inches. In areas of sandy soil conditions, the material is typically removed just prior to pouring the deck. Care should be taken that the concrete is worked into the area under the beam of the shell so that air voids are minimized. If desired, 3/4" holes may be drilled every 36" to aid bleeding air. Rebar or wire mesh should be used in the concrete deck. For decks using pavers, as shown in Figure 10, the concrete deck should be poured up to approximately 1/4" of the top of the pool beam. Deck should fall 1/4" per 12 inches of horizontal deck to allow any surface water to be drained away from the pool.

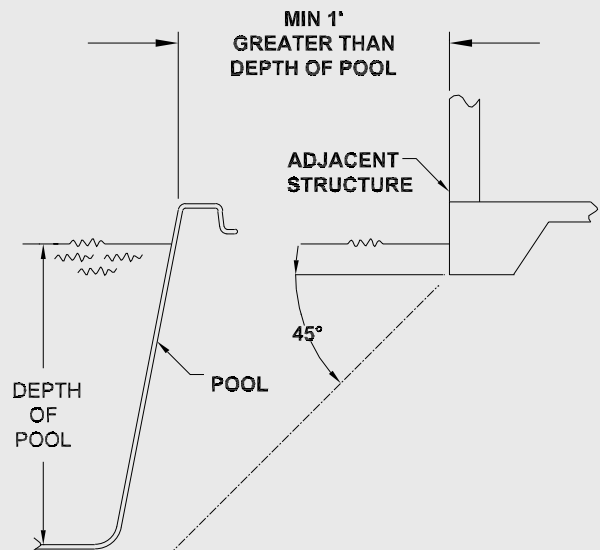
Half inch holes may be drilled into the outside edge of the pool beam of the pool every 3'. Two foot lengths of 3/8" pre bent rebar are placed in each hole (see Figures 9 and 10). This will ensure a bonding or anchoring effect on the sides of the pool. The walkway may also be reinforced with 6" No. 10 wire mesh or No. 3 rebar on 2' centers (see Figures 9 and 10). It is advisable to use a lifting chair/shoe/dobie to elevate the wire mesh and/or rebar to ensure this reinforcement is centered in the depth of the pour. Concrete should be poured at least 3' around the perimeter of the pool to divert the water away from the excavation cavity. The typical thickness of a concrete deck around the pool is 4 inches. Latham will not be held responsible for any concrete work, cracking, or any other failure in deck installation.

In all climates 6"-8" of 1/2 clean gravel is recommended under the concrete deck.

**Figure 9 -
Cantilever Concrete Deck (Typical)**

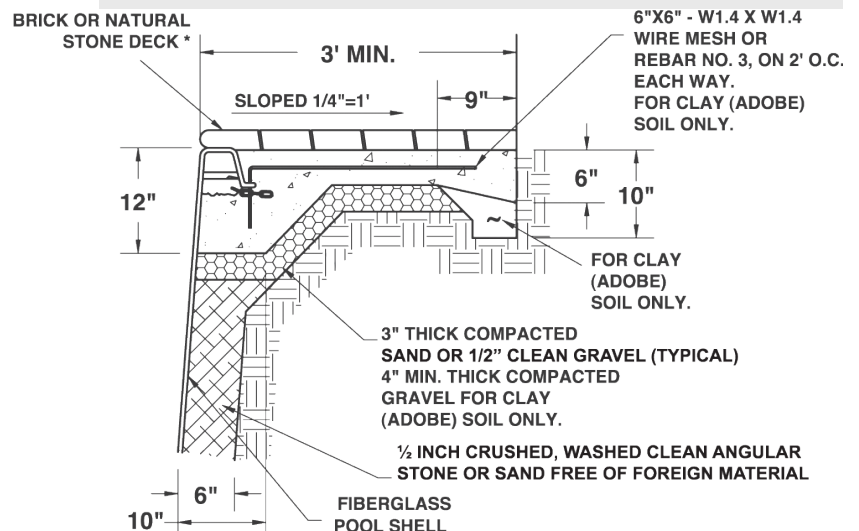


**Figure 11 -
ANGLE OF REPOSE
(NO INCREASED PRESSURE ON POOL
WALLS FROM ADJACENT STRUCTURE)**



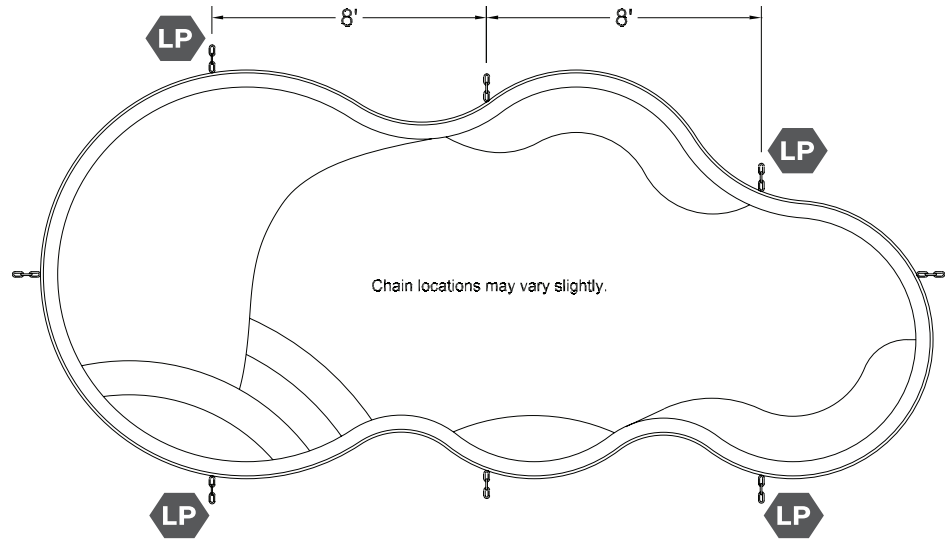
**Figure 10 -
Concrete Deck with Brick or Stone**

Deck size guide and additional deck
installation details available on request.



To be in compliance with Latham's installation practices and procedures, all Latham fiberglass pool shells must be installed using the materials noted in the Latham Installation Guides. Pools that are not installed using these materials are not in compliance and therefore any damage that occurs due to the use of improper materials is not covered by the Latham Limited Lifetime Warranty. The most recent Latham Installation Guide supersedes any and all previous Latham Installation Guides, conversations, emails, etc. If a situation presents itself on a jobsite that is outside of the scope of the methods, practices, procedures and materials specified in the Latham Installation Guide and requires the consultation and/or design of an independent expert (geotechnical engineer, structural engineer, etc.), the Builder and the independent expert assume all liability and responsibility for the structural integrity of the pool shell.

Figure 12 -
Chain Locations



LEGEND:

LP - Lifting Point

POOL LIFTING NOTE:

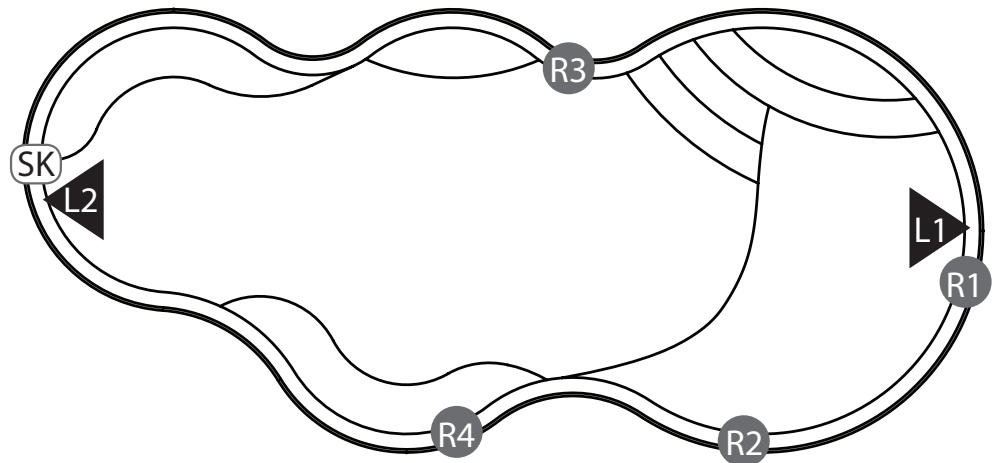
1. When being lifted from the trailer and/or set in the excavated installation site, four (4) 20' straps should be used. The 4 straps should be connected to a common lift point, typically the ball of the crane.

LIFTS SHOULD BE PERFORMED IN COMPLIANCE WITH ALL APPLICABLE STANDARDS SUCH AS OSHA AND ASME. SPECIFIC STANDARDS THAT MAY BE APPLICABLE ARE LISTED BELOW. THIS IS NOT AN ALL-INCLUSIVE LIST AND OTHER REGULATIONS WHICH MAY APPLY DEPENDING HOW LIFT IS PERFORMED AND EQUIPMENT USED.

ASME B30.5 OSHA 29 CFR 1910.133 OSHA 29 CFR 1910.179 OSHA 29 CFR 1910.180 OSHA 29 CFR 1926.753

IT IS THE RECIPIENT'S RESPONSIBILITY TO PROPERLY ASSESS THE SITUATION AND ACCOUNT FOR VARIABLES SUCH AS, BUT NOT LIMITED TO WEATHER, EQUIPMENT CONDITION, LOCAL REGULATIONS, ETC. BEFORE OFFLOADING CAN OCCUR. ANY DAMAGE RESULTING FROM THE LIFTING OF THE POOL SHELL IS THE RECIPIENT'S RESPONSIBILITY TO BEAR

Figure 13 -
Standard Fitting
Locations



LEGEND:

- SK - Skimmer
- R - Return Fitting
- L - Light
- OS - Optional Skimmer Location for Auto Cover Bundle

Drawing denotes approximate standard outfitting locations. Additional fittings and custom outfitting not shown.

WARNING TO THE BUYER:

The pool is designed to be kept full at all times. The shell can be damaged if the water level is allowed to drop below the skimmer. When appreciable draw-down is noticed, or if it becomes necessary to drain the pool, contact Latham Pool Products, or their agents for instructions. The pool shell may be damaged and separation from the concrete may occur if the pool is allowed to overflow or if heavy water drainage is allowed to over-run the deck to pool shell connection. Keep the water level in the middle of the skimmer. Latham Pool Products will not be held responsible for any unforeseen problems or circumstances which arise from inadequate site drainage or incorrect deck installation. Refer to the Latham Warranty for conditions, circumstances, or installation practices that may void the pool's warranty.

Notes

latham

The Pool Company™

www.lathampool.com

Latham Pool Products, Inc.
© 2022. All Rights Reserved.