

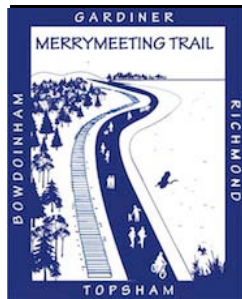

Merrymeeting Trail

*Connecting the Maine Communities of
Topsham, Bowdoinham, Richmond
and Gardiner*



Prepared for



Midcoast Council of Governments

and the

Merrymeeting Trail Committee

Prepared by



June 14, 2011

Table of Contents

	Executive Summary	
1.0	Introduction	1-1
2.0	Documentation of Physical and Environmental Conditions.....	2-1
3.0	Identification of Engineered Rail-with-Trail Solutions.....	3-1
4.0	Rail-with-Trail	4-1
	Segment 1 – Tetford Road to Cathance Road	
	Segment 2 – Cathance Road to River Road	
	Segment 3 – River Road to River Road	
	Segment 4 – River Road to High Street	
	Segment 5 – High Street to Lincoln Street	
	Segment 6 – Lincoln Street to River Road	
	Segment 7 – River Road to Gardiner Town Line	
	Segment 8 – Town Line to Gardiner Waterfront Park	
5.0	Assessment of rail-with-Trail Probable Costs.....	5-1
6.0	Identification of Alternate Routes.....	6-1
	Alt 1 – Cathance Road / Fisher Road	
	Alt 2 – Browns Point Road / Pork Point Road	
	Alt 3 – Richmond Village to Riverside Road	
	Alt 4 – West Side of the Railroad Corridor	
	Alt 5 – Riverside Road	
	Alt 6 - Rte 24 from Riverside Road past Riverview Drive	
	Alt 7 – Rte 24 from Riverside Road onto Riverview Drive	

Alt 8 – Rte 24 from Riverside Road Northward past Riverview Drive

Alt 9 - West of the Railroad Corridor

7.0 Summary7-1

Plans:

Rail-with-Trail Plans..... 1-40

Alternate Route Maps 1-15

Appendices

A “A Trail of Statewide Significance”
by Tom Reeves; Reeves Consulting, Gardiner, Maine

B Representative Photographs of Railroad Corridor and Alternative Routes

Executive Summary

Background

In 2008, the communities of Gardiner, Richmond, Bowdoinham and Topsham signed a Memorandum of Agreement at the request of the Merrymeeting Trail Committee to work together towards achieving the vision of establishing a regional trail system. In 2010, the Midcoast Council of Governments (MCOG), with support from the Merrymeeting Trail Committee, commissioned this feasibility study. MCOG received financial assistance for the study from Topsham, Bowdoinham, Richmond and Gardiner, the Maine Department of Transportation, the Maine Outdoor Heritage Fund, the Maine State Planning Office, and the Friends of the Kennebec River Rail Trail.

The Merrymeeting Trail Committee consists of representatives of the four municipalities, 21 organizations that are currently involved in or interested in supporting this project, and many citizens.

Within the railroad corridor, the multi-use trail would be planned as a “rail-with-trail” and engineered so that it does not interfere with future redevelopment of the railroad for freight and passenger service. The long term goal of this multi use trail is to link the four communities with a new mode of transportation for local and regional alternative transportation. Additionally, the trail would also provide increased recreational opportunities and promote healthy living and quality of life benefits. The trail would likely have secondary benefits in the form of increased tourism, improved access to natural areas, and enhanced identity for the four communities.

The proposed trail has outstanding attributes that should qualify it as a trail of statewide significance (see Appendix A). It would support non-motorized transportation from the Capital to the seacoast, and it would expand an intra-state trail system as called for by the State's Quality of Place Initiative. The trail would partially parallel the Kennebec River, which is just one of 18 rivers deemed by the Maine legislature as having “outstanding river stretches.” It would also cross the Cathance and Abagadassett Rivers and could be the backbone for a network of trails connecting publicly owned lands in this region. It will parallel the western side of Merrymeeting Bay, which is the largest freshwater tidal estuary north of Chesapeake Bay, as well as one of Maine's highest significant habitat areas for migratory bird and fish species (being a crucial feeding area along the Atlantic Flyway). The proposed 25 mile Merrymeeting Trail would link the 6.5 mile long Kennebec River rail Trail from Augusta to Gardiner with the 2.6 mile long Androscoggin River Bicycle and Pedestrian Path in

Brunswick and Topsham, forming a system extending over 35 miles in a part of Maine which has no major trail systems. When built, this would allow for an uninterrupted multi-use trail connecting the largest midcoast Maine community of Brunswick with the State capital of Augusta. It would also provide interconnected alternative transportation between the eight communities along the entire corridor. The East Coast Greenway Alliance will seek to have this trail become part of the Maine to Florida East Coast Greenway since both the Kennebec River rail Trail and the Androscoggin River Bicycle and Pedestrian paths are part of the Greenway.

Study

The VHB study team retained by MCOG was charged by the Merrymeeting Trail Committee with the task of laying the groundwork for a world class trail. The study assessed the feasibility of developing a multi-use rail with trail facility along the State-owned rail corridor that extends approximately 25 miles northward from Topsham to Gardiner. The study also evaluated alternate routes, should the use of the railroad corridor be challenging or prohibitively costly.

VHB documented the physical and environmental constraints along the railroad corridor by overlaying an ArcGIS geodatabase on 2003 and later high resolution orthophotography, which formed the basis for the project base mapping, as described in Section 2. Once the electronic base files were assembled, the study team performed a field review of the entire corridor, reviewing and modifying the GIS-based information based on real conditions in the field. The results of the data collection efforts were depicted on a set of 40 high resolution color plans that are part of this feasibility study.

Rail with Trail

VHB evaluated the feasibility of establishing an unpaved shared use trail on the east side of the railroad corridor. The east side offers unsurpassed, spectacular views of the Kennebec River, Merrymeeting Bay and a number of tributaries, marshes and wetlands, but it also experiences significant physical challenges and environmental constraints. The cost of constructing the East Side Trail was estimated to be about \$50 million, or about \$2 million/ mile on average. The East Side Trail costs are summarized in Section 5. Building the trail immediately to the west of the rail within the right-of-way would not result in significant savings.

By way of contrast, if the railroad corridor consisted of a double track for its entire length (only about 4 miles is actually double track today), removing one of the rail lines and building an unpaved trail would cost about \$7.7 million, or about \$0.3 million/ mile.

Alternatives

VHB also studied a number of alternatives aimed at circumventing the most environmentally challenging and costly sections of the rail corridor while also providing the user with an experience which can be equal to or greater than that along the railroad corridor. If fully implemented, the alternatives, which are discussed in Section 6, would reduce the cost of the Merrymeeting Trail by over half to about \$22 million, or roughly \$1 million/ mile. While the alternative routes would go around the most challenging sections of the railroad corridor, the trail would still generally follow the railroad corridor through the village areas of Topsham, Bowdoinham, Richmond, and Gardiner.

Conclusions

This feasibility study examined the development of a multi-use rail with trail along the State-owned railroad, as well as a number of alternate routes. This study does not recommend specific routes, but highlights the possibilities for further consideration by the involved individuals and communities.

Potential next steps and project development phases include:

- Selection of preferred routes within each community,
- Endorsement of preferred routes by public, local and State officials,
- Identification of phased implementation plans within each community and within overall corridor (master planning),
- Identification of potential funding sources,
- Commence fundraising efforts,
- Preliminary engineering,
- Local, State and Federal permitting,
- Right-of-way acquisition,
- Final design,
- Construction.

Introduction

1.1 Introduction

In 2008 the communities of Gardiner, Richmond, Bowdoinham, and Topsham signed a Memorandum of Agreement at the request of the Merrymeeting Trail Committee giving “support to our municipal staff, our residents, our municipal committees, and other interested parties to work together towards achieving the vision of this regional trail system.”

In 2010 the Midcoast Council of Governments (MCOG) commissioned this feasibility study on behalf of the four involved towns with guidance from the Merrymeeting Trail Committee. The study seeks to assess the feasibility of developing a multi-use trail within the State owned railroad corridor that extends approximately 26 miles from Topsham to Gardiner, or to develop alternate routes should the use of the railroad corridor be too challenging or prohibitively costly. Within the railroad corridor the multi-use trail would be planned as a “rail-with-trail” facility and engineered so that it does not interfere with future redevelopment of the railroad for freight and/ or passenger service. The long term goal of this multi-use trail that links the four communities is to facilitate local and regional alternative transportation. The trail will also provide increase recreational opportunities, promote healthy living and provide quality of life benefits. The trail will likely result in secondary benefits in the form of increased tourism, improved access to natural areas, and enhanced identity for the four involved communities.

The proposed trail will have outstanding attributes that should qualify it as a trail of statewide significance. It would connect two major rivers of Maine by new modes of non-motorized transportation. The trail would in part parallel the Kennebec River which is just one of 18 rivers deemed by the Maine legislature as having “outstanding river stretches.” It would also cross the Cathance and Abagadasset Rivers and could be the backbone for a network of trails connecting other publicly owned lands in this region and could parallel in part Merrymeeting Bay. The proposed 25 mile long Merrymeeting Trail would link the 6.5 mile long Kennebec River rail Trail from Augusta to Gardiner with the 2.6 mile long Androscoggin River Bicycle and Pedestrian Path in Brunswick and Topsham forming a system extending over 35 miles in a part of Maine which has no major trail systems. If built the East Coast Greenway Alliance will seek to have this trail become part of the Maine to Florida East Coast Greenway since both the Kennebec River rail Trail and the Androscoggin River Bicycle and Pedestrian paths are part of the Greenway.

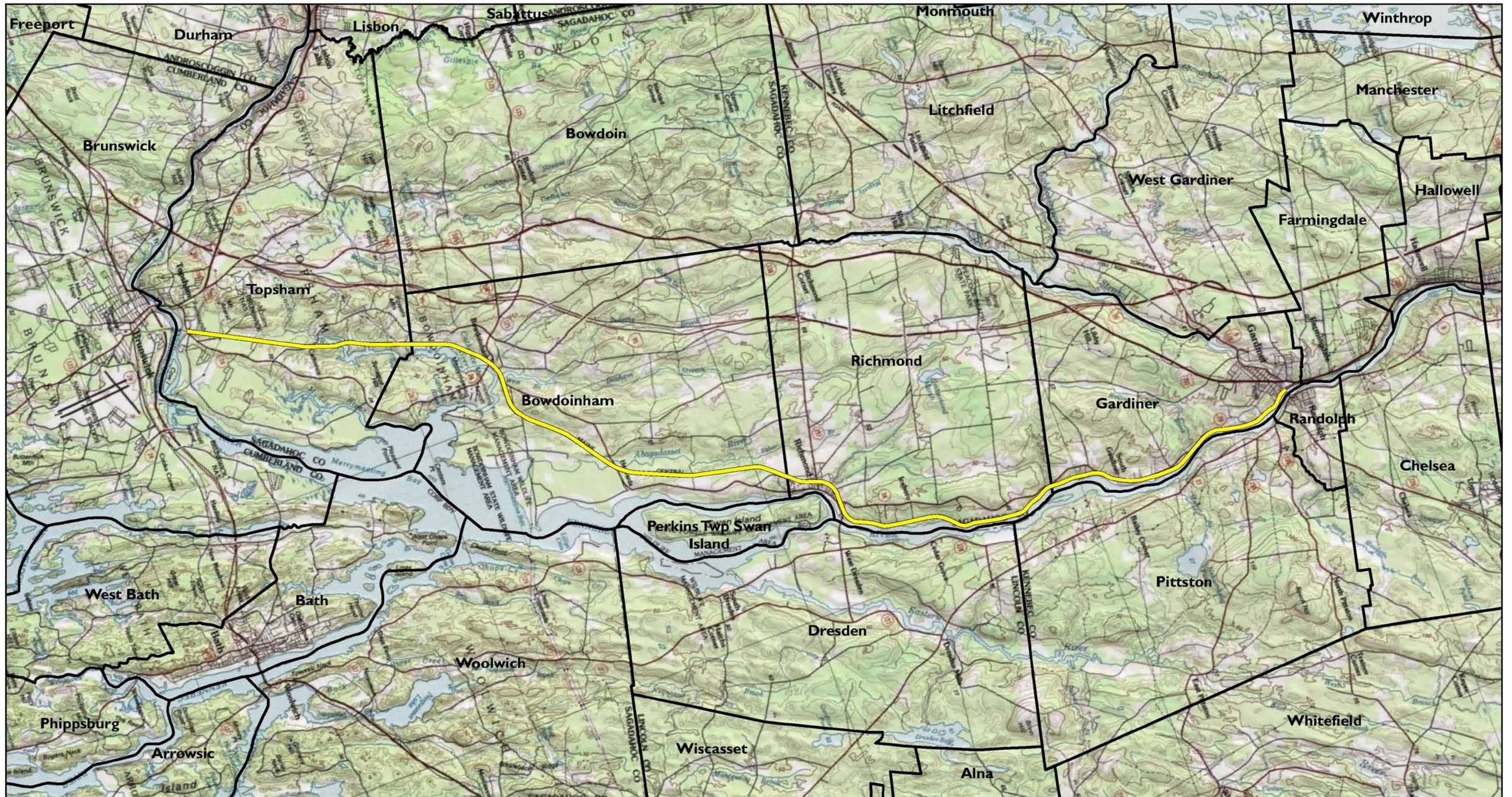

Legend
 Proposed Rail Trail

Figure 1
Proposed Merrymeeting Rail-Trail Project
 Towns of Topsham, Bowdoinham, Richmond, Gardiner
Rail-With-Trail

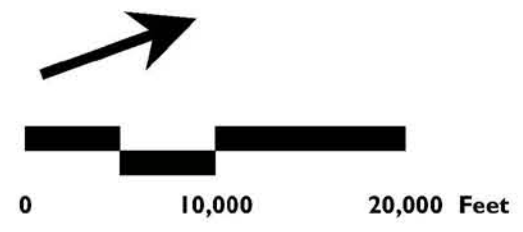

1.2 Background

MCOG received financial assistance from Topsham, Bowdoinham, Richmond and Gardiner, the Maine Department of Transportation, the Maine Outdoor Heritage Fund, the Maine State Planning Office Regional Challenge Program and the Friends of the Kennebec River Rail Trail to complete this feasibility and planning study.

Vision

The trail will be a true multi-use facility that will accommodate bicyclists, pedestrians and other non-motorized users.

The Merrymeeting Trail would connect the following locations:

- The Androscoggin River Bike Path in Topsham that links Brunswick to Topsham;
- The village area in Bowdoinham;
- The village area in Richmond;
- The village area in Gardiner; and
- The Kennebec River Rail Trail that links Gardiner, Farmingdale, Hallowell and Augusta.

The trail would connect Brunswick to Augusta as an alternative local and regional transportation route. The trail is expected to be heavily utilized due to its local and regional connectivity. The Kennebec River Rail Trail is a local example of a similar community trail and it experiences high daily recreational and alternative transportation use.

The Merrymeeting Trail will be part of the East Coast Greenway, a 3,000 mile national trail linking Calais, Maine with Key West, Florida.

Historical Background

The concept for the Merrymeeting Trail and the initial mapping was developed by Mainewatch Institute in its mapping project "Rediscovering Forgotten Assets: Trails for the 21st Century," in January, 2008. Regular meetings of the Merrymeeting Trail Committee have been held since May 2008 to refine the vision for the project. Some of their accomplishments include:

- Developed a Work Plan that is updated on a regular basis as plans evolve and progress is made.
- Developed a Stakeholder/ Interested Parties list that is updated on a regular basis
- Developed Memorandum of Agreement and secured support of four municipalities
- Selected preferred trail corridor

- Started the planning process for the railroad corridor using GIS data
- Obtained maps of the railroad right-of-way from Maine Department of Transportation
- Created Strategic Project Outline
- Started organizing four workgroups:
 - Organizational structure
 - Corridor planning
 - Funding
 - Public Outreach
- Created a project web site

Interested and Supporting Organizations

Organizations that are currently involved and/ or interested in supporting this project include:

- Midcoast Council of Governments
- Kennebec Valley Council of Governments
- National Park Service
- Kennebec Estuary Land Trust
- Brunswick-Topsham Land Trust
- Friends of the Kennebec River Rail Trail
- Kennebec River Network
- East Coast Greenway Alliance
- Merrymeeting Wheelers Bicycle Club
- Greater Topsham Trail Alliance
- Topsham Trail Riders
- Maine State Planning Office
- Maine Coastal Program
- Kennebec River Network
- Merrymeeting Arts Center
- Center of Ecological & Cultural Living Arts
- ACCESSHealth
- Healthy Communities of the Capital Area
- Cathance River Education Alliance
- Maine Downtown Center/ Maine Development Foundation
- Bicycle Coalition of Maine
- Maine Department of Transportation
- Mainewatch Institute

2

Documentation of Physical and Environmental Conditions

2.1 Introduction

Prior to developing solution alternatives it was first necessary to extensively document the existing physical and environmental conditions. This involved an extensive data gathering effort that included compiling electronic files, record plans and field based observations and measurements. The following section describes the data gathering methodology and results.

2.2 Data Collection Methodology

The VHB study team built on the initial work performed by the Merrymeeting Trail Committee to document the physical and environmental constraints as well as opportunities along the corridor that extends from the Route 196 bypass in Topsham to Waterfront Park in Gardiner. The study team's initial work primarily involved Geographic Information Systems (GIS) data gathering.

GIS Base Mapping

The GIS mapping utilizing available geospatial information was assembled and organized as an ArcGIS geodatabase and was overlaid on 2003 high resolution orthophotography, which has formed the basis for the project base mapping. To supplement the 2003 orthophotography, VHB obtained 2006 imagery from the Town of Topsham, and 2009 imagery from the USDA National Agriculture Imagery Program (NAIP) to help identify recent development/ constraints along the corridor. The following information has been incorporated into the geodatabase:

- National Wetlands Inventory/ Hydric Soils;
- The National Register of Historic Places
- Properties documented on Maine Historic Preservation Commission inventory forms;
- USGS Digital Elevation Model;

- The NRCS county soil surveys;
- Maine DEP's database of hazardous materials sites;
- National databases for CERCLA or RCRA sites relating to hazardous materials;
- Federal Emergency Management Agency (FEMA) Digital Flood Insurance Rate Maps showing floodway and floodplain boundaries;
- Tax map data showing approximate property lines and right-of-ways;
- Aquifers/ Surface Waters/ Streams/ Surficial Geology;
- Fisheries/ Wildlife/ Inland Waterfowl/ Wading Birds;
- Endangered/ Threatened Species;
- Essential Habitat;
- Geological Features;
- Forest cover Types;
- Land Cover Data;
- Hydrology;
- Conservation Land;
- Wells/ Public Water Supplies/ Water Quality.

VHB also scanned the railroad valuation maps provided by MaineDOT. These were electronically superimposed over the GIS mapping to evaluate potential right-of-way constraints and to understand the locations of drainage structures and bridges. In addition, the study team was provided numerous files from the local communities for inclusion in the base data.

Resource Agency Database Consultations

In addition to the GIS data referenced above, VHB contacted the following resource agencies for any available supplemental information:

- The Maine Natural Areas Program to identify known populations of state-listed threatened or endangered species and significant natural communities;
- The US Fish and Wildlife Service and Maine Department of Inland Fish and Wildlife to identify known populations of federally or state-listed threatened and endangered species and to identify known sensitive fisheries or wildlife issues, e.g., anadromous fish restoration programs in streams or federally managed wildlife research areas or refuges;
- The Natural Resources Conservation Service (NRCS) to identify whether important farmland soils (i.e., prime, unique, state-wide or locally important soils) or active farmlands exist in the project area;
- The Maine Department of Conservation, Bureau of Parks and Lands to learn if any properties in the project area have received Land and Water Conservation Fund grants and are therefore protected by Section 6(f) of the Land and Water Conservation Fund Act.

Field Review

Once the electronic base files were assembled the study team performed a field review of the entire corridor on April 26 and 27, 2010. The fieldwork was undertaken

by Greg Bakos, PE and Project Manager, and Dale Abbott, GIS Specialist. MaineDOT provided the study team with the use of one of its Hyrail vehicles and a driver to enhance the fieldwork portion of the study.



One important result of this effort was that the GISbased information was reviewed and modified based on real conditions on the ground. This was accomplished by using a Global Positioning System (GPS) based field computer that showed the GIS mapping as well as the user's position on the mapping. The environmental scientist identified and validated the presence or absence of key environmental resources

The environmental field review was important because GIS data is by no means a complete representation of the actual conditions. For example, the National Wetlands Inventory (NWI) does not depict all of the wetlands present in a given area since they are based on interpretation of aerial photographs and often miss smaller wetland resources. The fieldwork also allowed the study team to document the locations of large cuts and fills, ledge cuts and railroad drainage ditches. This information was not available from the GIS based contours and is central to developing engineered solutions and cost estimates.

For the purposes of this feasibility analysis, the fieldwork was performed at a reconnaissance level only. Thus, VHB did not attempt to formally delineate wetland boundaries, but instead adjusted the GISbased wetland boundaries based on visual field observations by an environmental scientist. In addition, the start and end points of additional wetlands were located in the field using GPS. The digital wetland boundaries were adjusted in the field and back in the office from the GPS data points that were collected by the field computer.

In addition to collecting data points and field adjusting resource boundaries, the study team made critical evaluations of the constraints and opportunities along every segment of the corridor. The physical constraints included steep embankments, narrow rail bridges, skewed road crossings, and narrow causeways through wet areas.

More than 500 data points and point descriptions were gathered in the field and the data that was gathered was then transferred to the base plans and subsequently annotated as appropriate.

2.3 Data Collection Results

The results of the study team's data collection efforts are primarily depicted on a set of 41 high resolution color plans that are part of this feasibility study. These plans use ortho-photography as a base and all of the relevant GIS and field collected data

layers are included. The study team used these plans in the next phase to depict solution alternatives.

The study team also collected relevant studies and maps from the Committee members and took many photographs during the field reconnaissance.

Summary of Data Collection Observations

During the field review stage it became immediately evident that the rail corridor contains significant physical and environmental constraints that will prove challenging to the construction of a continuous rail-with-trail facility. Clearly the railroad was built as efficiently as possible for single track service and the amount of cut and fill was minimized when it was constructed. As a result, construction of a parallel trail will require additional cuts, fills or engineered solutions such as retaining walls. The rivers, wetlands and streams form a natural boundary right at the foot of many of the fill slopes, and in cut areas the railroad only cut enough ledge to fit a train through. The challenging sections of trail are measured in miles and the “simple” sections are relatively short by comparison. The photographs on this page illustrate challenging ledge cut, steep fill and environmental resource constrained sections.



Typical Railroad Ledge Cut Section

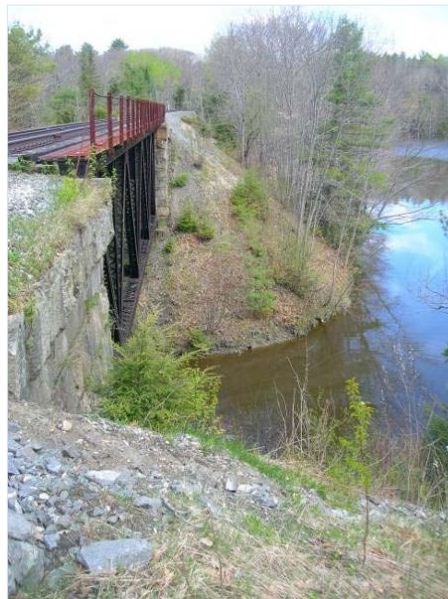

The photograph at left shows the Cathance River crossing. Note that the bridge approaches consist of long filled causeways with water on both sides for a portion of their length. The bridge itself is only wide enough for single track train use. It includes a narrow brakeman walkway with railing on the east side as shown.

This particular area appears to represent the most difficult segment of the trail due to the height and steepness of the slopes, the span of the bridge, and the environmental constraints at the bottom. Similar conditions exist at many other locations along the trail, but to a lesser degree of severity. It will still be difficult and expensive to construct rail-with-trail in some areas that are less dramatic than the few examples shown here.

There are also areas where rail-with-trail construction will be relatively straightforward. The southern end of the trail in Topsham has stretches where the topography is relatively level and the trail can be constructed with only minor slope work outside the right-of-way. There are also a handful of segments along the rail corridor where there are double tracks. Trail construction would be fairly easy in any segments where it becomes possible to eliminate the double track. The below photo shows one such double track segment where construction on the secondary track (right) would be relatively easy. It is not assumed that all of the double track will be available for conversion to single track with trail, for the Maine Department of Transportation may wish to maintain part of the double track.



The photo below shows a typical segment of rail corridor where the constraints are not severe. In this segment the trail would be constructed off to one side or the other. It would require clearing and minor earthwork to attain the required separation. The outer construction limits would likely go beyond the existing railroad right-of-way, but it should be possible to keep the actual path within the right-of-way.



The study team observed that even though there are many obstacles and constraints to building a rail-with-trail, the facility would provide tremendous benefits. It would provide a continuous shared use path with unique access to a variety of natural areas as well as village centers and community destinations. The following chapter discusses engineered solutions that could be employed to overcome the physical challenges that were observed along the rail corridor.

3

Identification of Engineered Rail-with-Trail Solutions

3.1 Introduction

The observations from the data collection phase shaped the types of design solutions that will be possible or necessary to achieve a continuous multi-use rail-with-trail from Topsham to Gardiner. This section discusses conceptual design solutions that could be employed to address the primary physical project challenges.

3.2 Design Criteria

Before design solutions could be developed it was first necessary to define the basic parameters that would govern the design of the trail. The following primary design criteria were developed to guide the design evaluation process.

Trail Width

The standard trail width is assumed to be **10 feet**. This is a widely recognized minimum desirable width for shared use paths. Lesser widths are allowed in extremely constrained locations if the trail use is not expected to be heavy, such as in remote areas, and greater widths are encouraged in areas where trail use is expected to be heavy, such as in village centers. It should be noted that 2 to 3 foot granular or grass shoulders would be included adjacent to the trail for safety as a clear and relatively level recovery zone for trail users that stray off the trail surface.

Trail Surface

There are at least three trail surface alternatives worthy of consideration for this trail. These are:

- Compacted granular material
- Asphalt pavement on compacted base of select granular materials
- Permeable asphalt pavement

Each of these surfaces has advantages and disadvantages as follows:

Granular Trail:

Many rural multi-use trails are constructed with a granular surface that is typically comprised of a well graded stone dust or “hard pack” material layer over a compacted gravel base.

Advantages:

- Least expensive to construct
- Appealing rural/ rustic appearance, which often fits in better within the rural Maine context
- Good surface for runners, walkers and equestrians

Disadvantages:

- Requires more frequent maintenance
- Susceptible to wear and erosion
- Surface not suitable for all users, such as roller bladders, strollers, and some bikes with narrow tires on loose or steep sections



Asphalt Paved Trail:

Asphalt paved trails are common in urban and residential areas where high use is expected and where paved surfaces do not appear out of place. The paved surface is typically 2 to 3 inches thick and the gravel / crushed gravel base is typically 12 to 18 inches thick, depending on the condition of the native subbase materials.

Advantages:

- Smooth and stable surface that accommodates all users
- Durable, even on steeper inclines

Disadvantages:

- More expensive than granular trail to construct
- Less compatible within certain rural or historic contexts than granular trails
- Long term maintenance (resurfacing) can be costly



In terms of initial investment the option to pave the trail adds between \$100,000 and \$200,000 per mile to the overall trail cost due to the asphalt pavement and increased depth of base material requirements. The majority of the trail development costs are related to constructing the wide stable subbase and all that goes into developing the basic trail including clearing, earthwork, ledge cuts, retaining walls, drainage swales, fences, railings, bridges, design, permitting and acquisition of land rights.

Permeable Paved Trail

Permeable asphalt or concrete paved trails provide an alternative surface to conventional paved trails in areas where stormwater runoff volume and water quality are of particular concern. Permeable pavement allows the rainfall to pass through to the base materials, so the base layers must be designed to collect and distribute that water.



Advantages:

- Allows stormwater to pass through pavement
- Accommodates all users
- Durable

Disadvantages:

- Most expensive option
- Requires annual maintenance (vacuuming)

Permeable pavement is not generally recommended for this project since it is questionable whether the actual benefits outweigh the added cost and maintenance concerns. Stormwater runoff from rural paved trails does not typically present a high level of water quality concern since the trail will generally be surrounded by vegetated slopes and swales where infiltration and treatment would occur. It is estimated that permeable asphalt pavement would cost approximately \$30,000 per mile more than conventional asphalt. Annual maintenance would consist of vacuuming the surface to remove fine particles from the voids which make the pavement permeable. Individual towns may still wish to pursue permeable pavement if they feel the positive public perception of the environmental benefits will outweigh the additional costs.

Rail with Trail Separation Distance

This is assumed to be a rail-with-trail project wherever the trail shares the railroad right-of-way. The existing track is currently not used except for an occasional excursion train. The Maine Department of Transportation wants to maintain the ability to accommodate freight and passenger service in the future and has the line under lease to the Maine Eastern Railroad.

The minimum separation distance between the trail surface and the closest rail should be **ten feet**, which is the design criteria that was used on the Kennebec River Rail Trail. Where possible, a setback from the nearest rail of greater than 10 feet should be maintained. In addition, fencing may be required between the trail and the track in constrained areas where there may be features on the other side of the track, such as the river, that might tempt trail users to cross.

The below typical section depicts the assumed minimum trail width and separation distance.

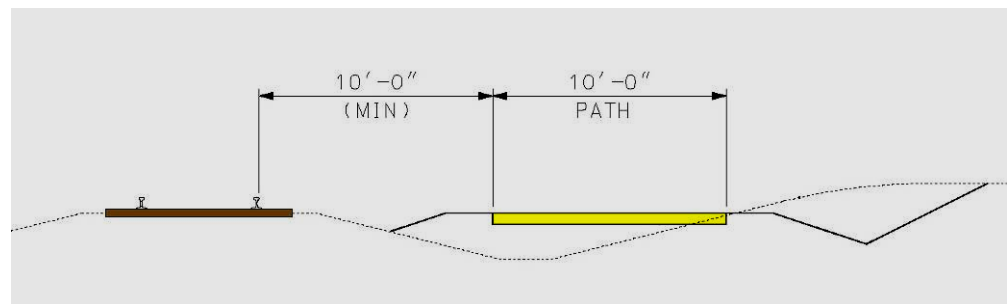

Grade

Rail Trails generally have very gentle profile grades that do not exceed 4% since they typically follow the profile of the railroad. There may, however, be areas where this trail will diverge from the railroad bed to minimize cuts and fills, or will use an alternate route, and in those cases the maximum grade might exceed 5% for short distances. The trail design should follow national design standards for bicycle facilities as well as public right-of-way accessibility guidelines. In general, long steep grades should be avoided where practical, and special accommodations, such as

increased width, switchbacks, resting platforms and railings should be considered when steep grades are unavoidable.

3.3 Rail-With-Trail Design Solutions

The following design solutions are conceptual in nature and are based on past experience with similar physical challenges and rail-with-trail design criteria. The study plans (see attached sheets numbered 1 through 41) use a color key code to depict where the various solution alternatives are envisioned along the railroad corridor. This is primarily based on observations and determinations made in the field and is subject to refinement as the project moves forward. Note that these rail-with-trail plans are based on the assumption that the majority of the trail would be constructed in or alongside the railroad right-of-way. The plans are in sequential order, beginning with sheet 1 in Topsham and ending with sheet 41 in Gardiner. The following trail typical sections are envisioned.

Normal Trail Typical Section

This typical section is depicted in the graphic in the above section. It involves constructing the trail a minimum of 10 feet away from the existing railroad track at approximately the same grade as the railroad bed. It is called “normal” because it does not involve significant cutting or filling or structural solutions.

Normal Fill Typical Section

This typical section is a cut or fill section where the existing railroad bed is on a built up section. Construction of the trail off to one side of the railroad bed will generally require substantial filling. It is called a “normal fill” typical section because there are no serious impediments to filling, such as wetlands or the river. The fill slopes might be steep but they do not require retaining walls. Fence or railing along the top of the slope may be required due to the hazard that the steep slope may introduce.

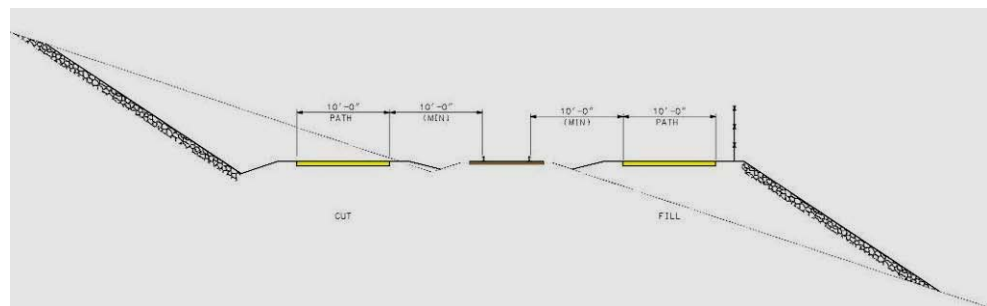

Extreme Fill Typical Section

This typical section is a fill section similar to the normal fill section, however there are impediments to allowing the fill slope to simply run out to where it meets the existing ground. This typical section occurs extensively along the river. The designed solution involves retaining the earth fill and building the trail up at nearly

the same elevation as the railroad track. The retaining wall system may involve simple solutions in low fills, such as gabion walls, or it may involve more aggressive retention systems such as soldier piles and concrete batters to retain the fill. Soldier pile walls are the recommended solution for the majority of this extreme fill condition where pile driving could be done from up above and where access from the river side would be restricted.

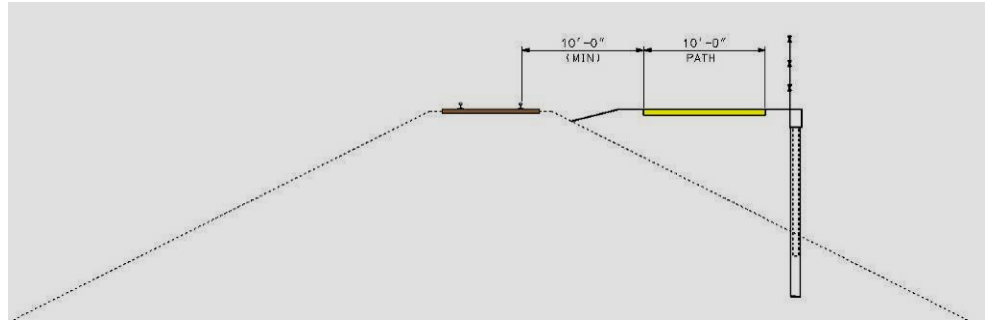

Ledge Cut Typical Section

In ledge areas the assumption is that additional ledge would need to be removed to accommodate the trail alongside the track as depicted below. Where possible it would be preferable to make the trail follow the existing ground elevations above the rail elevation since this would avoid or reduce the amount of ledge cut. Once accurate contours of the corridor are available it will be possible to refine the approach, but during the study phase the assumption is that some ledge removal will be required.

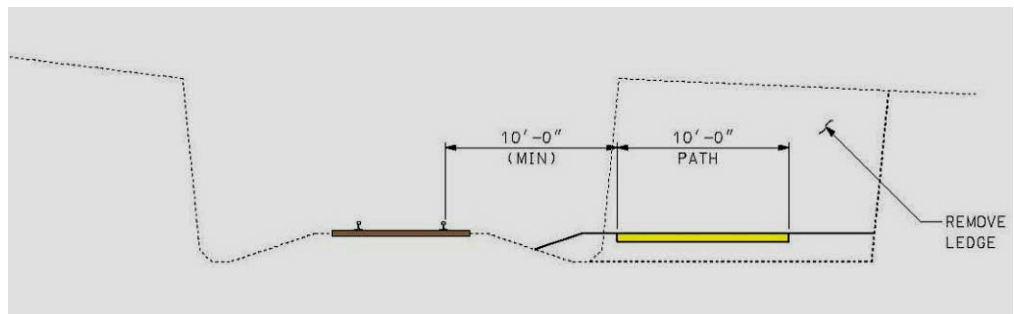

Proposed Bridges

The existing railroad bridges within the project are single track, so either the existing bridges need to be widened to accommodate the trail or new trail bridges need to be constructed adjacent to the railroad bridges. The assumption in this study is that the majority of the crossings would be accomplished on new bridges. This is partly because the existing bridges are of varying condition and it is often better to build new bridges that are not tied to the problems of the old bridges. In addition, it would be possible to attain greater rail / trail horizontal and vertical separation by

building new bridges. The photograph below shows a new trail bridge adjacent to an existing rail bridge.



Rail-with-Trail

4.1 Introduction

VHB evaluated the feasibility of establishing a multi-use rail-with-trail along the east side of the existing track within the railroad right-of-way. The east side offers unsurpassed, spectacular views of the Kennebec River, Merrymeeting Bay and a number of tributaries, marshes and wetlands. But it also poses significant physical challenges and environmental concerns. The study team examined the existing physical and environmental conditions discussed in Section 2 and applied the engineered solutions discussed in Section 3 to develop the east side trail estimates of probable costs that are summarized in Section 5.

The cost of constructing the east side rail-with-trail would be approximately \$50 million, or about \$2 million/ mile. Building the trail immediately to the west of the rail within the right-of-way would result in minor savings. The east side rail-with-trail is described in the paragraphs that follow on a segment by segment basis beginning at the project limit at Tedford Road in Topsham and extending northward to the waterfront park in Gardiner.

SECTION 1 - Tedford Road to Cathance Road

(Refer to plan sheets 1 thru 4)

Length: 9,363 Feet (1.77 Miles)

Town: Topsham

Cost: \$ 424,000.

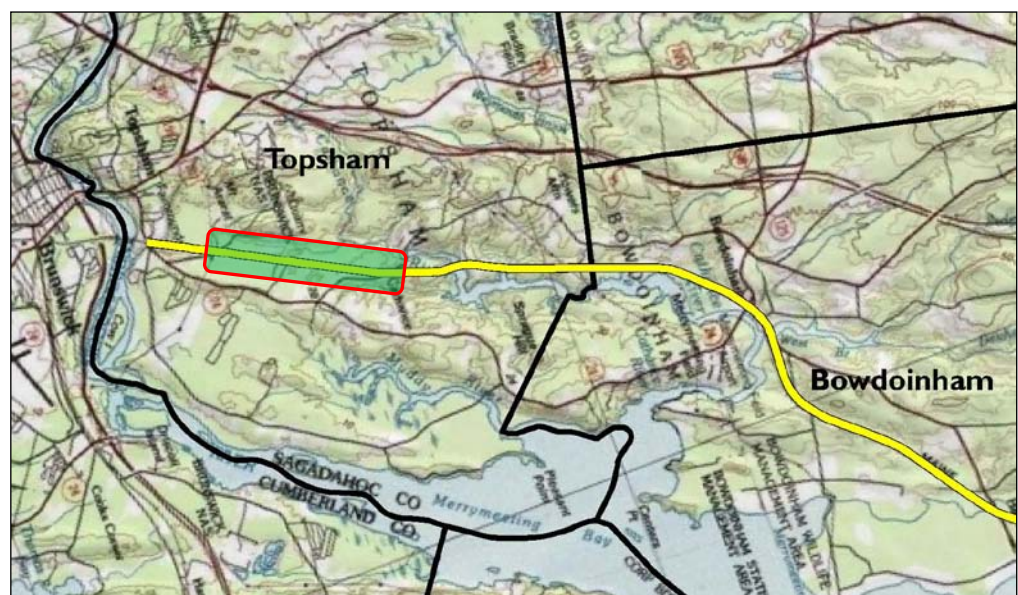

This section of trail extends from the southern beginning of the trail at Tedford Road to Cathance Road, all within Topsham. The southern end of this rail-with-trail segment would connect to the network of existing and proposed trails in Topsham. At the northern end of this segment the trail would also provide a connection to Head of Tide Park near where Cathance Road crosses the railroad. A portion of this segment includes an existing second track on the east side of the mainline track. If it is possible to replace the second track with the trail the construction would be relatively simple and inexpensive. The cost estimate for this segment assumes the rail trail will replace the second track.



This segment is arguably the easiest section of trail to build because the terrain that abuts the rail bed is relatively flat and there is generally sufficient room to construct the trail at least 10 feet from the mainline track. Total construction costs are estimated to be about \$424,000, which is relatively inexpensive in comparison to other trail segments because building the trail would not involve significant cuts, fills, ledge removal, or bridge construction. Minor right-of-way impacts are still anticipated due to slope impacts.

The Rail-with-Trail Plans that accompany this report depict the trail along the east side of the track in this segment, however the west side is very similar in terrain and features, with the exception of the segment of double track on the east side. The Plans also show the existing and/ or proposed trail network in Topsham that connects to the Merrymeeting Trail at Tedford Road. These trails will provide connectivity to the Merrymeeting Trail from Topsham destinations, including the Mount Aararat Middle and High Schools, and the Androscoggin Trail. Tedford Road and Beechwood Drive, which cross the railroad at grade, provide on-road connections for bicyclists to the nearby residential neighborhoods in Topsham.

The north end of this rail-with-trail segment is the at-grade crossing of Cathance Road. That crossing does not currently have flashers or gates for the railroad. Before the trail is constructed a diagnostic safety review should be conducted to determine the most appropriate pedestrian crossing enhancements. The enhancements will include advance signing, pavement markings, and possibly pedestrian actuated flashers.



SECTION 2 - Cathance Road to River Road

(Refer to plan sheets 4 thru 10)

Length: 23,128 Feet (4.38 Miles) **Towns:** Topsham/ Bowdoinham

Cost: \$ 7,993,000.

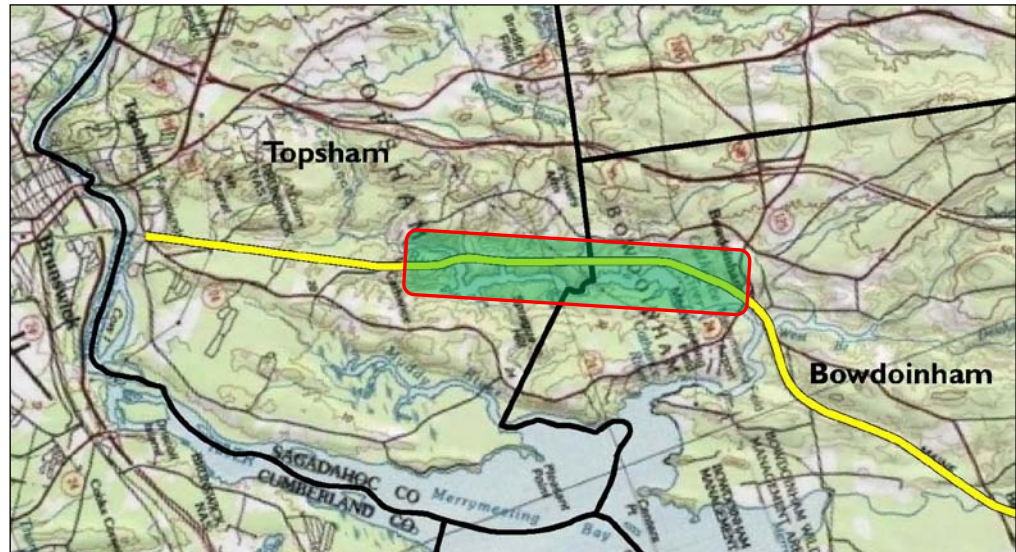

This long section of trail is relatively remote, passing through forests, wetlands and river systems. There are very few homes near the corridor and there are no road crossings other than the roads at each end of the segment. This segment includes the Cathance River crossing, which is the single most difficult location to construct rail-with-trail on the project due to the long, narrow and high bridge approaches. To achieve the required offset from the track, the trail would be supported on a new pedestrian bridge that would be constructed parallel to the existing railroad bridge. The pedestrian bridge would be approximately 140 feet long. The trail approaches to the new bridge would be difficult to construct since the existing embankment drops off steeply and since the trail would still need to be laterally separated from the railroad track. Long and costly retaining structures would need to be constructed to support the trail on the steep railroad embankment without impacting the riverbank and wetlands below.

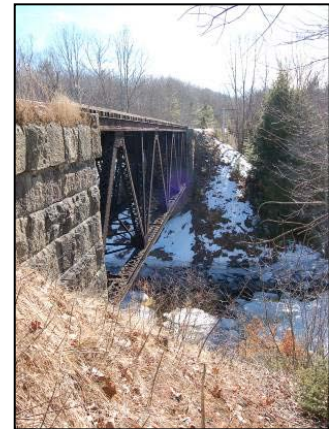

There are other steep and difficult sections within this segment, as indicated on the Plans, including a ledge cut area south of the Cathance River as shown in the photo to the right, and three steep wetland crossings north of the river crossing. This segment also includes a 2,700 foot long section of double track just south of River Road in Bowdoinham that could be available for constructing the trail.



SECTION 3 - River Road to River Road

(Refer to plan sheets 10 thru 16)

Length: 16,643 Feet (3.15 Miles)

Town: Bowdoinham

Cost: \$ 4,720,000.

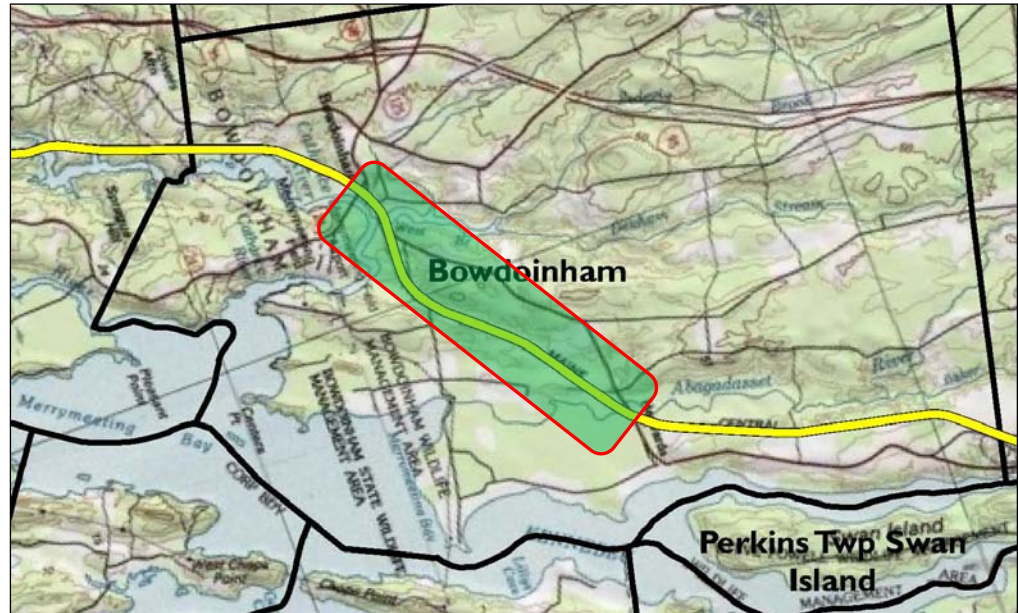

This segment begins at the River Road crossing adjacent to the Phillip Maily waterfront park in Bowdoinham and extends nearly three miles northward to where it crosses River Road again.

The waterfront park includes recreational opportunities and a parking lot which would likely provide some trailhead parking. Main Street extends from the waterfront park directly up into the center of Bowdoinham Village, thus providing good access between the trail and the village center. The northward facing photo on the right shows the beginning of this trail segment, with the double track ending in the foreground and the waterfront park parking lot in the background on the right.



Immediately north of the waterfront park is another very challenging section where the raised railroad bed is positioned between Route 24 and the Cathance River. Constructing a rail-with-trail along the river (east) side of the railroad would involve extensive retaining walls and two pedestrian bridges over the West Branch. This option would be costly and the trail fills would result in direct river impacts. Constructing a rail-with-trail along the



Route 24 (west) side of the railroad does not appear feasible without shifting the railroad toward the river and/ or Route 24 to the west.

North of the West Branch crossing the rail corridor passes through rolling wooded terrain away from the river, crossing Browns Point Road at grade, and then passing through areas with ledge cuts, shown at right, fills and wetlands in repeated rapid succession. Construction of rail-with-trail along this challenging stretch would likely require ledge cuts, large fills and retaining walls in wetland areas.



The railroad corridor crosses the Abagadasset River and one of its tributaries just prior to crossing River Road (Route 24) at grade, as shown below. The river crossings would require pedestrian bridges parallel to the railroad bridges as well as long retaining walls along the bridge approaches to minimize fills in the wetlands.

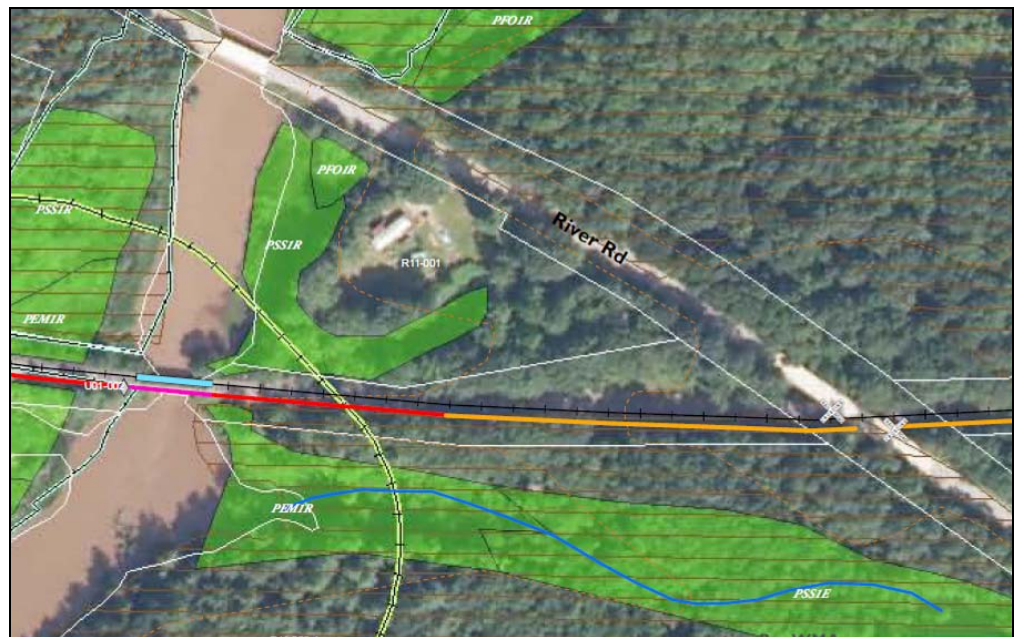

The at-grade River Road crossing shown has good sight distances, but crossing aids such as bike actuated flashers may be desired due to high observed vehicle speeds and skewed crossing angle.

SECTION 4 - River Road to High Street

(Refer to plan sheets 16 thru 22)

Length: 18,595 Feet (3.52 Miles)

Towns: Bowdoinham/ Richmond

Cost: \$ 1,470,000.

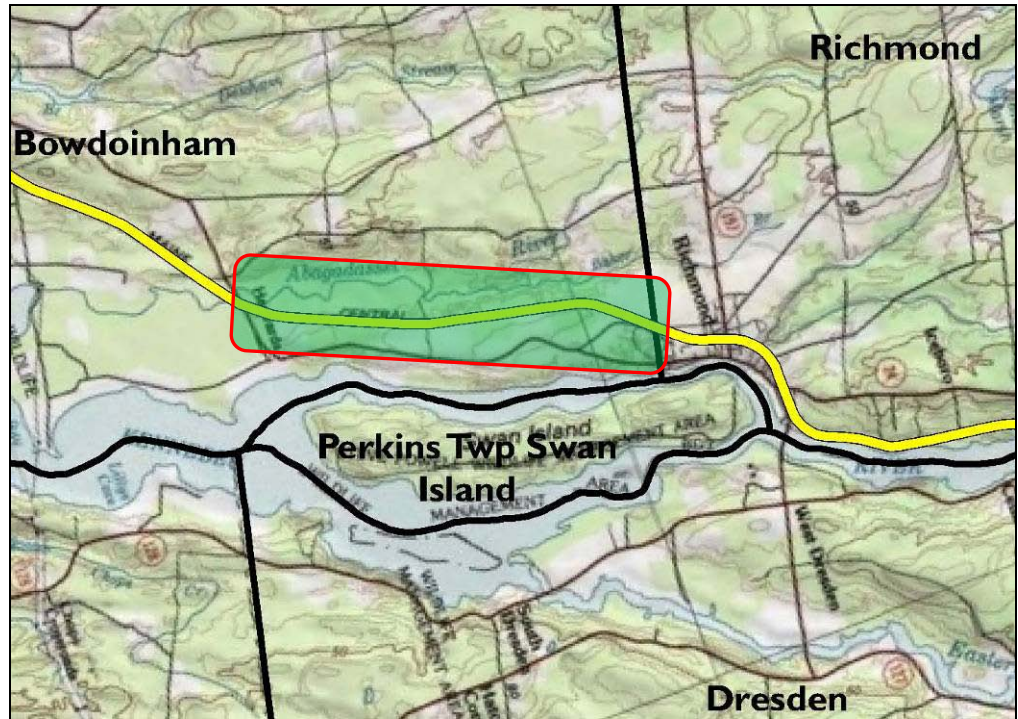

This segment passes through rolling wooded terrain and is set well away from the river. The rail corridor alternates between cuts and fills and there are small wetlands adjacent to the majority of fill sections. Construction of the rail-with-trail would result in expansion of the cuts and fills and would likely require retaining walls to minimize wetland impacts. This segment is therefore deceptively challenging to construct. It lacks the dramatic river crossings and high fills of other sections, but the rolling terrain dictates that the trail will almost always be in a ledge cut or a fill section if the trail is to remain relatively confined to the railroad right-of-way.



This segment ends at High Street, which is located on the Richmond side of the Bowdoinham/ Richmond town line. This segment combined with the previous segment would essentially provide a 6.7 mile long multi-modal connection between the centers of the two communities.

SECTION 5 - High Street to Lincoln Street

(Refer to plan sheets 22 thru 23)

Length: 5,824 Feet (1.10 Miles)

Town: Richmond

Cost: \$ 262,000.

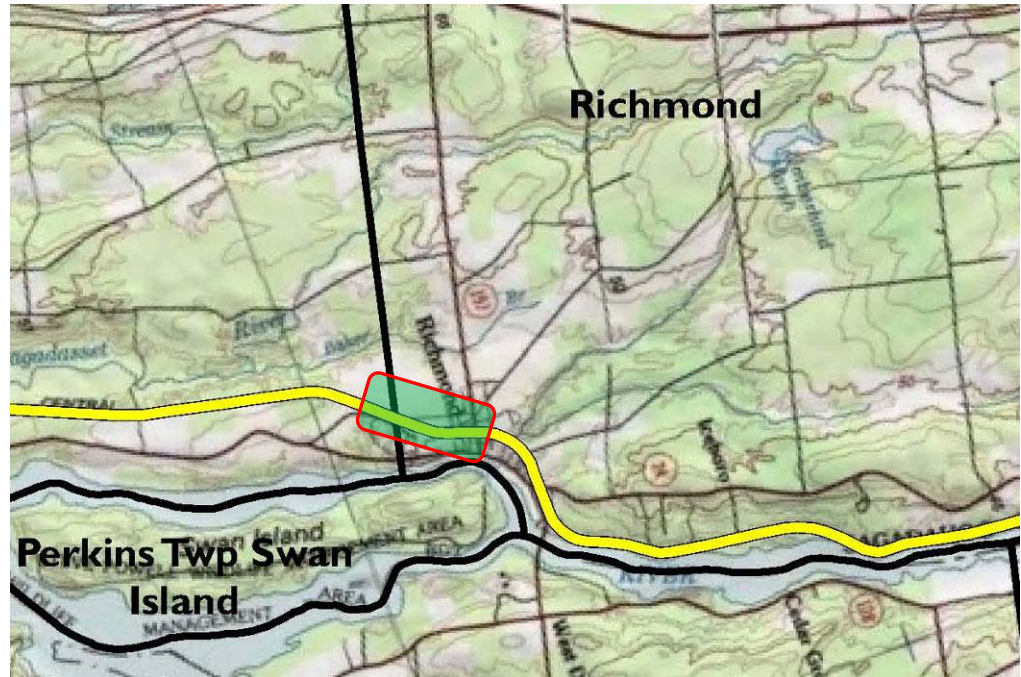

After crossing High Street at grade, the railroad corridor passes close to the Marcia Buker School as it enters the south side of Richmond village. The school and its associated athletic fields is an important origin/ destination, as is the village center beyond. The trail would provide an important alternative transportation function within the village, and it would also provide regional connectivity from the village center to the adjoining towns and beyond. This segment includes approximately seven road crossings, with Main Street being the busiest one. It will be important to add the appropriate crossing signs, pavement markings and possibly flashers at the busiest crossings. Wayfinding signs for trail users and trail identification signs for road users should be included all along the trail.

The rail corridor becomes very constrained between commercial buildings as it reaches Main Street. It may be necessary to deal with encroachments and utilize all of the remaining right-of-way for the trail. Paving the trail within the village center may help increase its visibility as a formal bike/ pedestrian facility.



SECTION 6 - Lincoln Street to River Road

(Refer to plan sheets 23 thru 24)

Length: 1,400 Feet (0.27 Miles)

Town: Richmond

Cost: \$ 1,213,000.

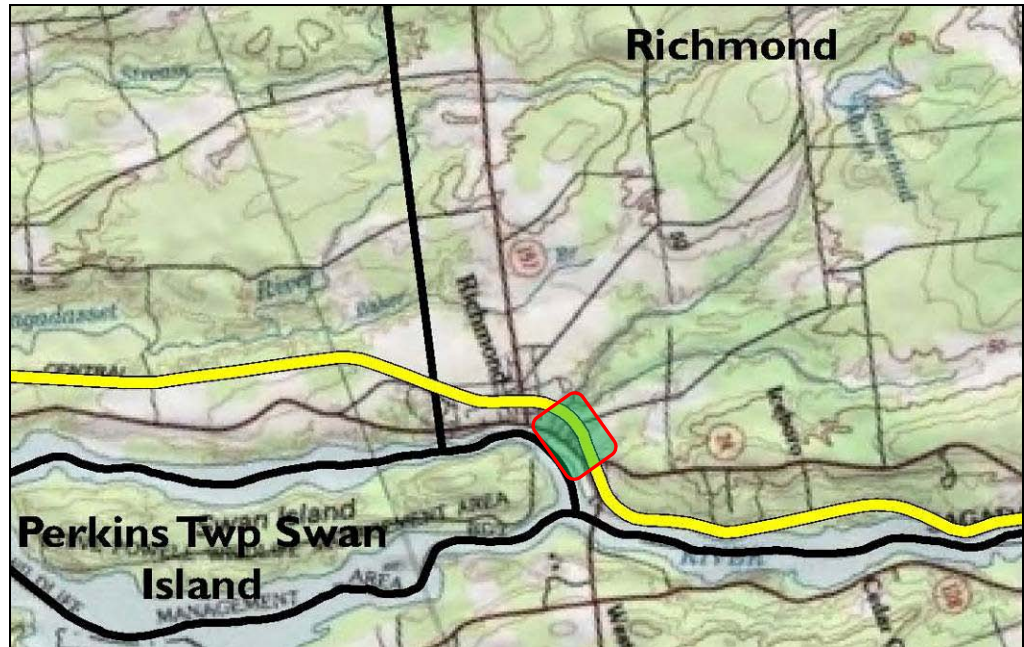

This short segment of rail corridor passes over a significant fill section between Lincoln Street and River Street in Richmond. This area will require special consideration since the engineered solutions, such as retaining walls, will be costly and difficult to construct. Both sides of the track have steep embankments, so the trail should be built on the side that makes the most sense for adjoining segments.



SECTION 7 - River Road (Route 24) to Gardiner Town Line

(See plans 24 thru 31)

Length: 26,096 Feet (5.50 Miles)

Town: Richmond

Cost: \$ 20,554,000.

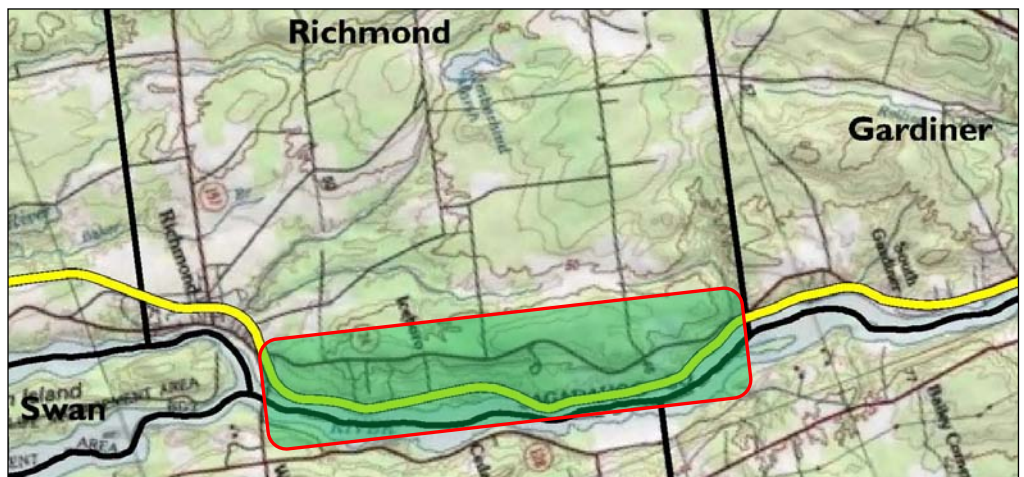

There would need to be a grade separated crossing of River Road at the beginning of this long segment. This could be accomplished with a prefabricated pedestrian bridge parallel to the existing rail bridge. The photo at right shows the existing railroad bridge over River Road, which rises steeply to the left. The trail would then follow the rail corridor at-grade across Old Ferry Road and then to the shores of the Kennebec River. It would then follow the river for the remainder of the segment.



This segment includes rolling forested terrain and excellent river views. The rail corridor alternates between ledge cuts and fills and there are long expanses where the railroad embankment slopes steeply down to the river. Costly engineered solutions in the form of retaining walls, similar to the one shown in the photo, would be required along this segment. The high costs and the potential difficulty obtaining environmental permits are the biggest challenges for this segment and others like it where the river abuts the railroad embankment.



SECTION 8 - Gardiner Town Line to Waterfront park

(Refer to plans 31 thru 40)

Length: 28,5415 Feet (5.40 Miles)

Town: Gardiner

Cost: \$ 12,995,000.

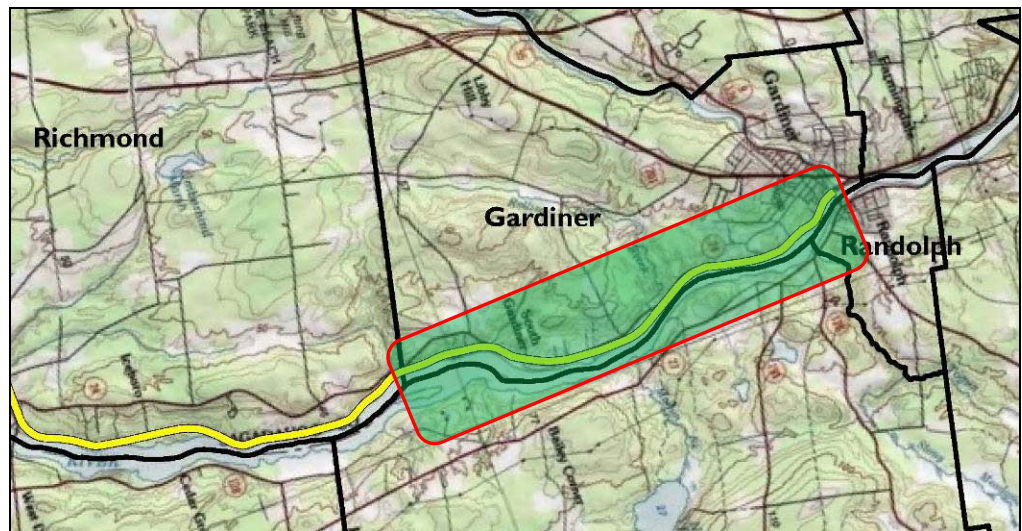

This final segment is similar to the previous segment in that it includes long stretches near the river. In addition, it passes by residential areas and the Riverview

Community School in South Gardiner. This segment also has independent utility since it connects the neighborhoods of South Gardiner to Gardiner center.

The railroad in the northern half of this segment is constrained by both the river and Route 24. Construction of a rail-with-trail through the riverside portions of this segment would be difficult and costly. The photo at the right illustrates the physical constraints that also include utility poles between Route 24 and the track.



Assessment of Probable Costs

5.1 Introduction

In order to evaluate the feasibility of the rail-with-trail project on a segment by segment basis it is first necessary to estimate the likely costs associated with the proposed improvements. At this early stage the costs are very conceptual in nature, as is the design. The estimated costs will, however, provide an overall order of magnitude guide as well as a way to compare individual segments.

5.2 Cost Estimating Methodology

The Study Team prepared two sets of cost estimates representing both a lower end and an upper end estimate:

1. **Assume double track replacement for entire 26 miles.** The first estimate assumes that if there were two sets of tracks for the entire distance (which there are not), one of the tracks could be converted to a trail for a total cost of \$7.7 million. The estimate includes the cost of removing rail and ties, building an unpaved path, and providing required fencing and other miscellaneous trail amenities.
2. **Rail with Trail: trail on east side of rail.** The Study team's engineers calculated linear foot construction costs for each of the rail-with-trail typical sections described previously. The lengths of each typical section were calculated from the plans as defined from the field observations. The linear foot costs were developed from current bid prices for the major construction items involved in each typical section, and contingencies, planning, engineering and permitting costs were also added. The linear foot unit costs therefore represent the conceptual total development costs per length of each type of typical section. The total rail with unpaved trail cost is estimated to be \$50. Million, exclusive of right-of-way costs.

5.3 Cost Estimating Results

The attached table represents a segment by segment breakdown of costs based on the calculated cost per linear foot of each typical section within the corridor. The mile segments are shown on the attached plans and are designated MP 30 on sheet 1 to

MP 56 on sheet 41. The mile posts shown on the sheets correspond to actual mile markers along the rail, the locations of which were recorded by the GPS-based field computer. It should be noted that the costs that are presented are for an unpaved trail as per the Trail Committee's direction. The additional cost to construct a paved trail is estimated to be \$3.7 million. This equates to an increase of approximately \$150,000 per mile for a paved path. This includes the cost of asphalt pavements as well as the additional select base materials that a paved path would require when compared to an unpaved path.

Identification of Alternate Routes

The study team's field observations show that constructing a continuous rail-with-trail facility from Topsham to Gardiner will be costly and difficult to permit and construct. The railroad corridor has very limited double track where one track could conceivably be converted to a trail, and there are long sections of the rail corridor where building the trail would be challenging and expensive due to the physical and environmental constraints. This reality warrants investigating alternative routes to circumvent the most challenging rail-with-trail sections. Some of the alternative routes would likely provide a "user experience" that is equal to or even superior to that along the rail corridor. Eight alternative solutions were evaluated as shown on the project map on the following page and as described below. The alternatives are also shown in greater detail on fifteen Alternative Route Maps that follow the Rail-with-Trail Plans. There may be other alternatives to the ones documented in this feasibility study, such as the trails and tracks shown on the Mainewatch Institute's planning maps; *Forgotten Assets: Trails for the 21st Century* (2008), but an examination of those potential alternatives or ancillary trails is beyond the scope of this study.

6.1 ALT 1 - Cathance Road & Fisher Road

Approximate Length: 4.9 miles

Approximate Cost: \$ 2.3 Million

Approximate Cost Savings vs. Rail with Trail: \$ 4.4 million

Cathance Road (Topsham) Fisher Road (Bowdoinham)

The most challenging location within the entire rail-with-trail concept is the railroad crossing of the Cathance River in Topsham. That crossing has long and narrow approach fills that tower over the adjacent water body and wetlands. Constructing a trail parallel to the railroad (rail-with-trail) will be a daunting endeavor, and engineered solutions, though possible, will be very expensive. Cathance Road (which becomes Fisher Road in Bowdoinham) provides a potential alternative route around this significant rail-with-trail hurdle.

Cathance Road runs through rolling, rural countryside and provides an alternative route that would start where Cathance Road crosses the railroad track north of mile 32. Cathance Road becomes Fisher Road where it enters Bowdoinham. Fisher Road then enters Route 125 (Main Street), and the route returns to both the railroad corridor and to Route 24 in Bowdoinham Village.

Cathance Road could be made into a "bike route" with relatively little effort; however that level of improvement would fall well short of the Merrymeeting Trail

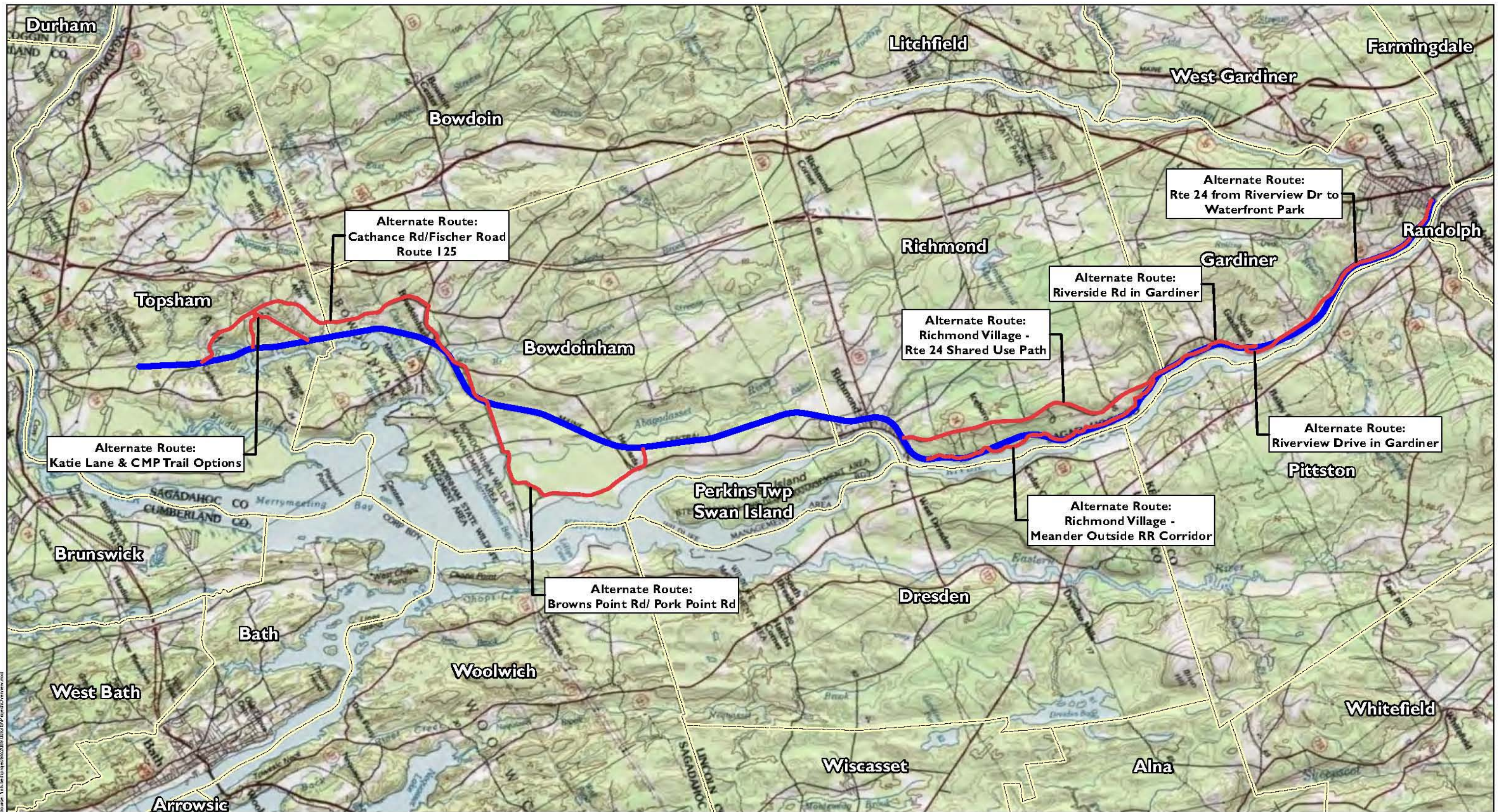

- Legend**
- Merrymeeting Trail
 - Alternate Route
 - Town Boundary

Overview Map
**Merrymeeting Trail
 Corridor Study**
 Topsham to Gardiner Maine
 March 2011

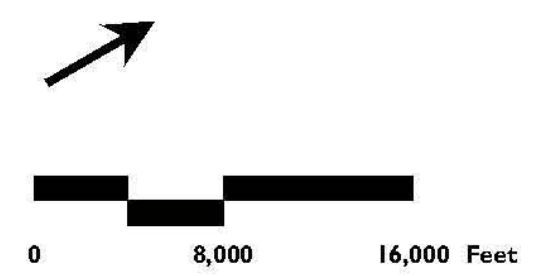

vision in that it would only accommodate a narrow set of users comprised mostly of experienced cyclists who are comfortable riding on the side of narrow, rural winding roads with rolling hills.

It would be possible to add paved bike lanes to Cathance Road to make it more “bike friendly”; however this would do little to accommodate pedestrians, children or inexperienced cyclists. This is not consistent with the goals and vision of the project. Furthermore, adding paved shoulders on both sides would increase the overall pavement width which could lead to increased motor vehicle speeds on Cathance Road.

To better satisfy the vision for the Merrymeeting Trail along the Cathance Road corridor it would be necessary to construct a shared use path. The shared use path would be constructed to a width of ten feet and would be separated from the road by a vegetated buffer or by guardrail with pedestrian railings for safety where the available width is constrained. The assumption is that the path would roughly follow the roadway alignment on one side or the other. The path would be built within the roadway right-of-way where there is room, and where there is insufficient right-of-way width additional space would be acquired. To enrich the experience of trail users and to improve safety, the buffer between the road and the path would be maximized where practical.

A field review of Cathance Road was conducted to assess the feasibility of such a shared use path. The number of trail / road crossings should be minimized due to safety and operational considerations, so special consideration should be given to keeping the path on one side of the road if practical.

The field inspection quickly revealed that the Cathance Road alternative is not without physical, environmental and property constraints, however it is considerably more feasible than the rail-with-trail option. The following paragraphs describe some of the primary considerations and/ or challenges within this alternate route.

Terrain

Cathance Road is similar to the railroad in that it was built on a series of cuts and fills through the rolling terrain. As a result, there are segments where constructing a shared use path adjacent to the road would require significant cuts, fills and/ or retaining walls. The use of a context sensitive design approach is encouraged due to the number of homes adjacent to Cathance Road as well as the rural scenic nature of the corridor. The Cathance Road corridor is not nearly as physically challenging as the rail corridor in this region, but it should not be considered an “easy” alternative.



Cathance River Crossing

By following Cathance Road the shared use path would still need to cross the Cathance River. The existing steel girder bridge shown here is approximately 24 feet wide so a parallel prefabricated pedestrian bridge would likely be the best solution. Such a bridge would need to be approximately 80 feet long if positioned south of the bridge, and 100 feet long if positioned north of the bridge. Although not funded yet, the Town is planning to construct a prefabricated pedestrian bridge on the north side. The pedestrian bridge should therefore be designed to accommodate bicyclists, and the shared use path should therefore continue in both directions along the north (east) side of the road.



Property Impacts

There are approximately 64 individual properties on the west side of Cathance Road and 64 on the east side. In addition, there are approximately 25 homes that are in relatively close proximity to the road on the west side and 35 on the east side.

Developing a shared use path with a vegetated buffer between it and the road will invariably result in right-of-way impacts to the majority of the adjacent properties. At the same time the path would provide a valuable amenity to the affected properties. Some of the property impacts will be minor in nature, while others will involve extensive slope impacts, depending on the topography. Some of the impacts will be of little consequence since they will occur in wooded or open areas that are well removed from any homes or buildings. The assessed values for these sorts of impacts should be low. But where the homes are close to the road the consequences from the impacts could be more pronounced and the design concessions and compensation to the homeowners is expected to be higher. In some instances the impacts will affect driveways, fences, mature trees and other landscape features, and mitigating these impacts through design modifications such as roadway alignment shifts and reductions in trail width may be necessary.

The photograph that follows shows the Bennett property on the east side of Cathance Road. Note the fence, utility pole and the mature trees on both sides of the road. This location is one of several severely constrained locations on the Cathance Road alternate route. A solution may involve bringing the path right up to the edge of the road and either protecting it with guardrail or delineating it with striping and warning signs. It may also be possible to shift the fence a few feet onto the Bennett property to provide more room for the path.



If this alternate route is pursued a more detailed assessment of actual home values and likely right-of-way impacts would be warranted to make a final decision on which side of the road the path should be constructed on.

Route 125

The Cathance Road / Fisher Road alternate route reaches Bowdoinham village via Route 125 (Main Street). Route 125 provides a 0.6 mile long connection through the village to Route 24. Shoulders and sidewalks are either missing or narrow along Main Street; however the Town has plans to construct a 5' wide sidewalk and on-street parking along the south side to School Street. This will preclude the construction of a shared use path along that stretch, however it may be considered more acceptable for bicyclists to either ride in the road or walk on the sidewalks once they are in the village.

The Cathance Road/ Fisher Road/ Route 125 alternate route can rejoin the Merrymeeting rail corridor at the base of the Main Street hill.

Analysis:

This alternative provides considerable cost savings vs. rail-with-trail. It does this by avoiding the severe challenges at the railroad bridge crossing of the Cathance River, as well as other rail-with-trail constrained areas (ledge cuts, large fills, etc.).

This alternative connects well to the Bowdoinham village center and other sections of the community, including the residences along the corridor.

The route is moderately hilly when compared to the flat rail with trail. Though potentially challenging to children or inexperienced cyclists, the hills also add interest and make for a varied experience.

Constructing the shared use path with an adequate buffer from the road will result in right-of-way impacts to frontages of many of the properties along the road. This

alternate route will at the same time provide the abutters direct access to this wonderful alternative transportation and recreation asset.

This alternative will closely parallel the roads as described above, which will be a different trail experience than the rail-with-trail option. It will, however, provide an interesting rural trail experience with its own set of views and points of interest.

Within Bowdoinham village there is insufficient space for a shared use path, however cyclists will be accommodated in the low speed village center road, and pedestrians will use sidewalks. Children and inexperienced cyclists may walk their bikes on the sidewalks within the village center if they are uncomfortable riding in the road. The village centers are important destinations along the Merrymeeting Trail.

Cathance Road Sub-Alternate Routes

There are three “sub-alternatives” that were also examined. All three consist of connections from Cathance Road back to the railroad corridor in an effort to shorten the length of shared use path that follows the roadway. These are shown on the overall route map and described as follows:

ALT 1.1 - Katie Lane connection:

This sub-alternate returns to the railroad corridor from Cathance Road a short distance north of the railroad bridge over the Cathance River. Katie Lane is a very low volume paved residential dead-end street. It was deemed undesirable by some Trail Committee members because it is relatively hilly and winding. The low traffic volumes suggest that the road could be used as a bike route rather than constructing a separate shared use path, however the path would be the first choice since it would also accommodate pedestrians. This sub-alternate is good in that it returns quickly to the railroad corridor, but there would still be challenging rail-with-trail sections to contend with north of the Katie Lane connection.

ALT 1.2 - Central Maine Power (CMP) power line right-of-way:

This is a potential connection back to the railroad corridor from a point on Cathance Road just north of Katie Lane.

The Trail Committee questioned whether the CMP corridor would provide a good experience for trail users since the corridor appears to be mostly cleared and since the power lines and towers dominate the scene. The early consensus was that it would not be a suitable environment for a trail of this importance. The corridor is also hilly and not without wetlands in the low areas.

A viable solution may be to construct the trail through the woods along the edges of the CMP right-of-way. It is not currently known whether the woods provide suitable width on either side of the corridor, but if they do this sub-alternate may be viable, assuming CMP is agreeable to the concept.

ALT 1.3 - Connector between Fisher Road and the Railroad Corridor

There are several large properties that extend between Fischer Road and the railroad corridor, one of which has an easement held by the Maine Farmland Trust. It may be possible to gain permission to construct the trail between Cathance Road and the railroad along the border between or elsewhere within one or more of these properties. This connection would avoid the constrained sections along Route 125 (Main Street) through the village and would provide an easier connection for bicyclists from the alternative route back to the rail corridor.

6.2 ALT 2 – Browns Point Road / Pork Point Road

Approximate Length: 5.3 miles

Approximate Cost: \$ 4.0 Million

Approximate Cost Savings vs. Rail with Trail: \$2.3 Million

Browns Point Road, Bowdoinham

This mostly alternate route would provide relief from some difficult rail-with-trail sections north of the center of Bowdoinham. This alternate route is not without its own challenges, as described below, but it also includes unique attributes that make it very worthy of consideration.

Causeway

The first challenge will be going between Main Street and Browns Point Road along Route 24. The town of Bowdoinham is improving Route 24 with sidewalks from the waterfront to Ridge Road, but the segment along the causeway will be difficult and costly. One option is to widen the northwest side of the Route 24 causeway to expand the existing sidewalk visible in the photo below into a shared use path. This would be an alternative to constructing a rail-with-trail path on the river side of the railroad track. The path could potentially be partially built on a pile supported deck to minimize wetland impacts. Guardrail would separate the path from Route 24.



Property Impacts

Once beyond the wetlands the path would be cut into the adjacent embankments with a narrow grass buffer between it and the road. Several of the adjacent homes are close to the road and it would be difficult to minimize impacts to their driveways, lawns, fences and trees. The photograph that follows is an example of a property located between the causeway and Browns Point Road where it would be extremely disruptive to construct a shared use path parallel to the southbound side of Route 24. For this reason it would be preferable to keep the path on the river side of the railroad (rail-with-trail option). The river side option would also eliminate the need to cross Route 24 in this area, and it would provide continuity from the waterfront park to Browns Point Road.



This alternate would include a separate shared use path along Browns Point Road and Pork Point Road which eventually returns to Route 24. This scenic alternate route could initially be an on-road route since it is on low volume roads with good pavement and in most areas adequate sight distances. Signs would be used to designate the route, and rather than bike lanes it may be desirable to install shared access arrows (also known as sharrows, shown below) to the pavement to alert motorists that this is a bike route.



Once funding becomes available to construct an entirely off-road shared use path along Browns Point Road it appears that the east side of the road would be the most accommodating and it would also provide the best views and rural experience.



The bridge that heads east towards Browns Point is a concern in that it is narrow and it does not have bike or pedestrian safe railings. The bridge effectively functions as a one lane bridge today, however the low volumes and speeds appear to support this. A separate parallel shared use path bridge would need a considerably longer span than the existing bridge since the existing bridge approaches are also very narrow and would not accommodate a path. Pile supported prefabricated spans may be the best solution if a separate path is envisioned in this location since this would minimize resource impacts. If the existing roadway bridge is scheduled for replacement it may be preferable to modify the new structure and approaches to also accommodate either a path or wider shoulders and railings, than to build a separate bike/ ped bridge. In the interim it may be best to improve the railings and add “Share the Road” signs at either end to alert motorists that they may see oncoming bicyclists on the bridge.



At the end of Pork Point Road where it intersects Route 24 there may be opportunities to travel directly west across open and wooded land for a short distance to reconnect with the rail corridor where the trail will head north as rail-with-trail to Richmond Village.

Analysis:

This alternate route provides considerable cost savings compared to the rail-with-trail corridor. Constructing the shared use path through the constrained causeway and bridges area along Route 24 will still be difficult and costly. Once past the Route 24 area it will be relatively easy to construct a shared use path parallel to the roads, although the stream crossing at the narrow Browns Point Road bridge will be costly and potentially difficult to permit.

This alternate would result in property impacts due to the construction of the shared use path, however once past the Route 24 area there are few homes close to the road.

The Browns Point Road/ Pork Point Road shared use path would provide a very scenic user experience. The route is already popular with on-road cyclists.

6.3 ALT 3 – Richmond Village to Riverside Road

Approximate Length: 4.4 miles

Approximate Cost: \$ 2.0 Million

Approximate Cost Savings vs. Rail with Trail: \$15. Million +/-

Richmond Village to Riverside Road in Gardiner.

There are two alternate routes to consider:

1. Route 24 Shared Use Path
2. Path along west side of Railroad Corridor

Route 24 Shared Use Path. This potential alternative route would involve constructing a shared use path primarily along the east side of Route 24 from the Route 24 railroad overpass in Richmond to Riverside Road in Gardiner. This alternative would avoid significant riverside sections of rail-with-trail that are challenging and very costly to build.

The Route 24 alternate would entail temporary and permanent right-of-way impacts along private residential property. There are segments where the right-of-way appears to be sufficiently wide and level to accommodate the trail, however, it may be desirable to locate segments of the path further off the road to improve the buffer and therefore the user experience.

Analysis:

This alternate route provides considerable cost savings compared to the rail-with-trail corridor since it avoids severe rail-with-trail constrained areas (ledge cuts, large fills, bridges).

The shared use path along Route 24 is not as remote as Alternative 4 on the west side of the railroad, but it offers the user its own form of scenic experience traversing open fields and attractive mixed growth forest with views of historic farmsteads. Although Route 24 is not an officially listed scenic byway by the Maine Department of Transportation it is described as one of the most scenic routes in Maine in John Gibson's book, *Maine's Most Scenic Roads: 25 Routes off the Beaten Path* (1998). If allowed to cross private property, the shared use path could be built with an interesting meandering alignment that would offer a similar experience for pedestrians and bicyclists. This alternative would provide the residents that live along and near Route 28 with direct access to this regional trail.



6.4 ALT 4 – West Side of Railroad Corridor

Approximate Length: 4.4 miles

Approximate Cost: \$ 3.7 Million

Approximate Cost Savings vs. Rail With Trail: \$13.0 Million +/-

West Side of Railroad Corridor Alternate.

This alternative would extend the trail along the west side of the rail line, either within the right-of-way or to the west of it. Constructing the trail west of the rail line would avoid construction and filling immediately adjacent to the river and would therefore have less of an environmental impact. It would, however, involve the purchase of easements or land from the adjacent private property owners.

The intent would be to allow the trail to meander outside of the railroad right-of-way to avoid significant constraints or impacts to wetlands. The trail would follow the topography to minimize steep grades and large cuts and fills. This would greatly reduce construction difficulties and costs, and would also result in a more interesting trail alignment and profile than the east side rail-with-trail.

Analysis:

This alternate route provides considerable cost savings compared to the east side rail-with-trail option since it avoids severe rail-with-trail constrained areas (ledge cuts, large fills, bridges).

This scenic path would follow interesting horizontal and vertical alignments to avoid difficult areas, such as wetlands and ledge outcrops. This alignment would provide greater separation distance from the railroad track than the east side rail-with-trail option, which would be advantageous if rail service is ever renewed.

Acquiring easements or license to use the adjacent private property is expected to be less difficult and costly than the Route 24 shared use path option because the homes in this area tend to be clustered along the roadway as opposed to the railroad right-of-way.

It has been suggested that this west side rail corridor route and the Route 24 route could both eventually be constructed since they provide such different experiences, and would create a dramatic loop trail connecting the village centers of Richmond and South Gardiner.. Both alternatives offer many benefits and are worth exploring further.

6.5 ALT 5 – Riverside Road

Approximate Length: 1.0 miles

Approximate Cost: \$ 0.02 Million

Approximate Cost Savings vs. Rail-with-Trail: \$1.5 Million

Riverside Road, Gardiner

Riverside Road in Gardiner provides a parallel alternate route that eliminates the need for significant rail-with-trail construction along the river. Route 24 does not provide a viable alternate route in this area due to the terrain, so Riverside Road is the only viable alternative to rail-with-trail.

Riverside Road is a level unpaved town road that receives very little automobile traffic, and therefore it may not be necessary to construct a shared use path. Signing could be used to designate the route and to direct cyclists and pedestrians to stay along the sides of the gravel road.



Analysis:

This alternate route provides considerable cost savings compared to the east side rail-with-trail corridor since it avoids severe rail-with-trail constrained areas (large fills, walls, bridges).

Using this road for the trail is not as desirable as a shared use path, although it is a considerably more feasible alternate than the rail-with-trail option.

Rejoining Route 24 at the north end, as shown in the below photo, would involve constructing a shared use path behind the guardrail to avoid entering traffic and to skirt around the adjacent wetlands between Route 24 and the rail corridor.



6.6 ALT 6 – Route 24 from Riverside Road to Past Riverview Drive

Approximate Length: 1.0 miles

Approximate Cost: \$ 0.8 Million

Approximate Cost Savings vs. Rail With Trail: --minor

Route 24 from Riverside Road to past Riverview Drive

This alternate route continues the shared use path northward along Route 24 from the point where the Riverside Road alternate ends at Route 24.

The shared use path would follow the east side of Route 24 up to where it would cross Route 24 to the River View Community School with assistance from a pedestrian signal and possibly curb extensions to improve motorist recognition of the crossing. The below photo facing northbound shows the general area where the crosswalk might be positioned. Note the wide shoulders, good sight distance and space to build the shared use path.



North of the school the Route 24 corridor becomes very constrained. There is a cemetery, homes and walls on the west side and a steep embankment down to the railroad corridor on the east side. These constraints could possibly be dealt with through engineered solutions and reduced path width, but the costs would be high. The photo below shows one such constrained area.



Analysis:

This alternate avoids rail-with-trail constrained areas and associated costs. It provides good access to the River View Community School.

Route 24 is very constrained north of the school. This alternate may be easier to construct than the rail-with-trail, however it will be difficult or impossible to get through the constrained sections north of the school where there is a cemetery, residences and steep slopes.

6.7 ALT 7 – Route 24 from Riverside Road onto Riverview Drive

Approximate Length: 1.0 miles

Approximate Cost: \$ 0.5 Million

Approximate Cost Savings vs. Rail With Trail: \$ 0.5 Million

Route 24 from Riverside Road then onto Riverview Drive

This is an alternative to the one discussed above in that instead of continuing along Route 24 it diverts onto Riverview Drive. It would still include a shared use path connection to the River View Community School. On Riverview Drive the improvements would involve reconstructing the existing sidewalk to a continuous and uniform 5 foot width along the west side of the road to accommodate pedestrians. Cyclists would be accommodated in the road since traffic volumes are very low and the paved surface is good. The photo below of Riverview Drive shows the existing narrow sidewalk that would be replaced with a continuous 5 foot wide sidewalk. Also note the clear view of the river to the left.



Analysis:

This very scenic alternate is easier to construct than the rail-with-trail, and it will avoid the constrained Route 24 sections north of the school. It will, however, still provide a connection to the school.

Riverview Drive is a very low volume and low speed residential road, so on-road cycling seems appropriate and adequate as opposed to constructing a shared use path. Upgrading the sidewalk to a continuous and consistent 5' width will still improve access for pedestrians.

6.8 ALT 8 – Route 24 from Riverside Road Northward past Riverview Drive

Approximate Length: 3.4 miles

Approximate Cost: \$ 3.5 Million

Approximate Cost Savings vs. Rail With Trail: \$5.5 Million

South Gardiner to Waterfront Park, Gardiner

There are two alternatives to consider:

1. **Route 24 Shared Use Path.**
2. **West Side of Rail.**

Route 24 Shared Use Path

This potential alternate route would include a shared use path primarily along the west side of Route 24 from the Richmond town line to near the project end at Waterfront Park in Gardiner. This alternate would not be without constrained segments but it would replace an extremely costly segment of rail-with-trail along the river.

The photo below shows a constrained area where the options include replacing the metal bin walls with a two tier wall system that would perch the shared use path above the road on a constructed terrace. These options would be very difficult and costly, and they would result in right-of-way impacts. A potentially more feasible option would include constructing the path at the base of the existing bin walls and shifting the road to the east. That option would include a barrier between the path and the road, and it might also require reducing the road width. These options would also be costly; however the rail-with-trail option along the river would be even more difficult and costly.



Analysis:

This alternative would produce cost savings compared to Rail-with-Trail on the river side, however some sections will still be costly.

This alternate provides good access to the trail from intersecting roads and neighborhoods.

The path experience adjacent to Route 24 will differ than under the rail-with-trail option along the river.

The path will likely need to cross Route 24 twice.

6.9 ALT 9 – West Side of Rail Corridor

Approximate Length: 3.4 miles

Approximate Cost: \$ 3.5 Million

Approximate Cost Savings vs. Rail With Trail: \$5.5 Million

West Side of Rail Corridor

This alternate route would extend the trail along the west side of the rail line instead of the river side. Constructing the trail west of the rail line would avoid retaining wall construction and fill immediately adjacent to the river and would have less of an environmental impact. It would involve moving utility poles and in some locations creating adequate separation distance from the railroad by modifying the alignment and geometry of the road.



The photo above shows a typical segment where a shared use path would be difficult to construct west of the track due to the close proximity of Route 24 and the utility poles. A solution could include shifting the poles to the opposite side of Route 24 and constructing a retaining wall and guardrail to support and protect the path.

Analysis:

This alternate would result in considerable cost savings and reduced environmental impacts compared to the Rail-with-Trail option on the river side.

7

Summary

If the Merrymeeting Trail were constructed along the east side of the railroad corridor it would provide wonderful views of the Kennebec River, Merrymeeting Bay and other streams, woodlands and wetlands. However, it may prove to be challenging to obtain the requisite environmental permits from the regulatory agencies and it would be very costly to construct. The high construction costs and the potential difficulties obtaining permits from the regulatory agencies place the feasibility of the continuous rail-with-trail concept into question, and thus alternative solutions were explored.

The alternate trail solutions that were presented in this feasibility study provide lower cost solutions with reduced environmental impacts. In many instances the alternate routes provide their own unique trail experiences that include inviting views and unique natural settings.

It is estimated that the alternate routes could reduce the overall project construction costs by as much as 28 million dollars. This is accomplished by avoiding the worst of the challenging rail-with-trail sections. If built this trail would be accessible to a region of Maine where nearly half of its population resides and as described in Appendix A has the characteristics necessary to qualify it as a trail of statewide significance.

This feasibility study is intended to help the communities and various stakeholders define their priorities and select the preferred Merrymeeting Trail options that will be advanced in subsequent phases of project development.

Appendix

A - A Trail of Statewide Significance

- by Tom Reeves; Reeves Consulting, Gardiner, Maine

A trail of statewide significance is one of significant length, connecting population centers, and serving multiple communities. There are only three trails in Maine which have been designated by the Maine Department of Transportation as trails of statewide significance. These are the Downeast Sunrise Trail, The Mountain Division Trail, and the Eastern Trail.¹

The proposed 26 mile long Merrymeeting Trail will connect the State's capital, Augusta with its 6.5 mile long Kennebec River Rail Trail to Brunswick and Topsham's Androscoggin River Bicycle and Pedestrian Path. These trail systems will link eight communities and offer expanded transportation and recreational opportunities to over 66,000 people who live and work in the eight communities, and over 588,000 people (46% of the State's population) who live within 30 miles of these trails.

Brunswick

Brunswick has a population of 21,000 and would be the largest community connected to the trail. It is situated at the head of Casco Bay and along the Androscoggin River. It is home to Bowdoin College, which has approximately 1,700 students, and which is consistently ranked among the 10 top liberal arts colleges in the United States. Brunswick is just 28 miles north of Portland, Maine's largest city. Brunswick was rated second in 2004 as a top 10 emerging market for second homes in the United States by EscapeHomes.com. The Androscoggin River Bicycle and Pedestrian Path, constructed by the Maine Department of Transportation, has helped Brunswick become one of the most bicycle friendly towns in the country. Brunswick is the only town in Maine to receive the designation of "Bicycle Friendly Community" by the League of American Bicyclists and is just one of four

t

¹ <http://www.maine.gov/mdot/opt/pdf/biketourismexecsumm.pdf>

communities to receive this designation in New England. The Merrymeeting Trail would connect with the Androscoggin River Bicycle and Pedestrian Path and the city's other bicycle and pedestrian facilities. Both the Androscoggin River Bicycle and Pedestrian Path and the Kennebec River Rail Trail are part of the East Coast Greenway, a planned 3,000 mile long off-road bicycle and pedestrian trail extending from Calais, Maine to Key West, Florida. It is envisioned that the Merrymeeting Trail will be part of the Greenway.²

Topsham

Topsham has a population of about 9,100 and is situated where the Androscoggin River enters Merrymeeting Bay. The southern terminus of the Merrymeeting Trail will be in Topsham. Topsham's 2005 Comprehensive Plan emphasizes its regional relationships: "As the bicycle and pedestrian network in the region grows, we believe our town has a tremendous opportunity to connect communities together and provide our residents with a higher level of service. These important connections include the Androscoggin River Swinging Bridge, the Frank Wood Bridge, a potential Androscoggin River Bike Path, and trail corridors in rural Topsham." The plan adopts as a strategy "to improve the bicycle and pedestrian connections between our town and neighboring communities"³ (p. 87).

With a one-mile radius of the terminus of the Merrymeeting Trail and the Androscoggin Bike Path are four schools (Woodside K-5, Williams Cone K-5, MSAD 75 Mt. Ararat Middle and High Schools, all of which have either implemented or have planned pedestrian connections to the Bike Path systems. The MSAD 6-12 population is nearly 2,000 students. Highland Green retirement community is directly adjacent to the trail. It is one of Maine's fastest growing retirement communities and bills itself as an "active lifestyle" residential community. Highland Green is linked through improved facilities (sidewalks – future bike path) and seven miles of hiking trails along the Cathance Corridor which terminates at Head of Tide Park adjacent to the Merrymeeting Trail.

Bowdoinham

Bowdoinham is on the west side of Merrymeeting Bay. The Cathance, Abagadasset, and Kennebec Rivers all flow through this rural village community of 2,600. The trail would extend through the village center, abut Philip Mailly Park, and be within easy walking distance of the community school and library. The trail would serve as a

² <http://www.greenway.org/>

³ Topsham's Comprehensive Plan 2005 (as amended in 2007) p.25
<http://www.topshammaine.com/vertical/Sites/%7B95A28B10-4485-4BEC-B8FC-5E8BF056A147%7D/uploads/%7BA020BC80-219B-4377-B9CB-741D3EDCB92A%7D.PDF>

link to several Inland Fisheries and Wildlife management areas and lands managed under conservation by the Maine farmland Trust and other land trusts.

Bowdoinham is not served by public transit nor does it have an extensive sidewalk network. The Merrymeeting Trail would serve as a spine for connecting Bowdoinham by non-motorized modes. In addition to providing local transportation the trail would be consistent with the economic, natural resources, and recreation goals for Bowdoinham's Comprehensive Plan (2000) and its Waterfront Plan (2005). Both plans note the importance of the village center to the economic and social well being of the community: "The economic vitality and the attractiveness and livability of the village area are inextricably linked." The Comprehensive Plan notes the need for "safe places for walking and biking and for off road recreational trails available to the public."

Richmond

Richmond is a community of 3,300 inhabitants on the Kennebec River. The trail would extend through the village center and would abut the elementary school and be just a couple of blocks from the middle and high schools and its waterfront park. The trail would be consistent with the vision for non-motorized transportation contained in Richmond's Comprehensive Plan (1990) which in its section on a suitable transportation network notes: "Access and transportation play an important role in determining the quality of life. This includes transportation in its broadest senses including the opportunity to walk, ride bicycles or utilize public transportation" (p. 36-37). The plan calls for promoting "the Village as a pedestrian environment," expanding "the opportunities for trails and walking paths in outlying area of the community," and viewing the railroad right of way as "a significant resource for a wide variety of potential uses including transportation (short line rail service, pipeline, bikeway), communications (fiber optic network), and recreation (linear park and trail system)." This right of way offers the "potential for creating long distance walking paths that could link local trails and assure a permanent backbone of a path system for the Town" (p. 12, 37, 67 and 111). The Richmond Village Downtown Revitalization Plan (2004) establishes a goal to "Make Richmond the most "Walkable" Village in Maine" (p. 7).

Swan Island

Richmond is the access point for Swan Island. The Master Plan for Swan Island (Winter, 1999 - 2000) describes the 4 mile long island as "a wildlife sanctuary, wildlife management area, an abandoned 19th century village listed on the National Register of Historic Places, a recreational resource, an open space preserve on the edge of a growing community, and a natural resource located in a watershed which is the largest tidal estuary on the Atlantic coast" (p. 5). The Master Plan calls for establishing "a framework that encourages partnerships with similar or complementary organizations" (p. 46). In 2010 the Commissioner of Inland Fisheries and Wildlife issued an updated management plan as a report to the joint Standing

Committee on Inland Fisheries & Wildlife which notes the suggestion for rail trails in Richmond and the need for better connectivity to the island through them (p. 24).

Gardiner

Gardiner is a riverfront community of 6,200. The Merrymeeting Trail would pass by Riverview Elementary School, the village center of South Gardiner, and end in downtown Gardiner's newly reconstructed waterfront park on the Kennebec River. The Merrymeeting Trail would be in close proximity to Gardiner's other three schools.

The trail would connect with the 6.5 mile long Kennebec River Rail Trail and the planned Cobbossee Corridor Trail.⁴ The planned Cobbossee Corridor Trail is a strategic component of the Cobbossee Corridor Master Plan (2005). One of the key goals of the plan "is to improve access to the Stream and associated open space, and make connections between the Corridor, the KRRT, the downtown and waterfront park, and adjacent neighborhoods and three nearby schools" for pedestrians and bicyclists.⁵ Gardiner has created a specific zoning district for the Cobbossee Corridor which seeks to maximize visual and physical connections to "a network of pedestrian trails."⁶ This urban zone is the first of its type in Maine to focus on non-motorized transport as a focus of land use development.

The three trails would all provide easy access to Gardiner's historic riverfront downtown district which is on the National Register of Historic Places. Downtown Gardiner is also part of the Main Street Program and is one of four communities selected in Maine to start this program.⁷ Gardiner has the strong potential for being a hub for trails.

The bridge between Gardiner and Randolph is the first bridge upstream from Bath to have a sidewalk offering access to non motorized traffic to both the east and west sides of the Kennebec such as the Narrow Gauge Rail Trail in Randolph. With their relatively small sized populations the communities on the east side of the Kennebec view the west side trails as a regional asset. Thus, Randolph's 1996 Comprehensive Plan establishes as a policy participating "in regional recreation programs and facilities" (p. 60). Chelsea's 2003 Comprehensive Plan notes that "the town is dependent upon the automobile for access to work, shopping and recreation" and

t

⁴ Cobbossee Corridor Bike/Ped Trail Design Report (December, 2009)
http://www.gardinermaine.com/Public_Documents/GardinerME_EcDev/CobbosseePDRRevMay2009.pdf
Cobbossee Corridor Trail Route. http://www.gardinermaine.com/Public_Documents/GardinerME_EcDev/trailroute.pdf

⁵ Cobbossee Corridor Master Plan, p.18-19.
http://www.gardinermaine.com/Public_Documents/GardinerME_EcDev/CobbosseeCorridorMasterPlanpages11_20.pdf

⁶ Gardiner zoning districts. Section 7.5.12
http://www.gardinermaine.com/Public_Documents/GardinerME_PCode/Section7ZoningDistricts4.21.10.pdf

⁷ Main Street Maine. http://www.mdf.org/mdc_main_st_maine.php

that for pedestrian modes “sidewalks are not available which is usual considering the town lacks a town center and is a rural community” (p. 32, 42). The plan notes that the community has access to “regional recreational resources” such as the Kennebec River Rail Trail and calls for Chelsea to develop “regional solutions” (p. 52, 54). Pittston’s 2005 Comprehensive Plan observes that “the most significant influence on Pittston’s 20th Century has been the automobile” and that “opportunities for other forms of transportation” for this rural community are “currently very limited” (p. 9, 29). Though Pittston has extensive river frontage on both the Kennebec and Eastern Rivers it has no significant public access to these resources (p.45). The plan does see “opportunities in nearby towns” and has adopted a policy to “cooperate with neighboring towns on access and management of the Kennebec River” (p. 45, 56). This form of cooperation may echo the historical fact that Gardiner, Randolph and Pittston were originally all one town incorporated as Pittston in 1799.

Gardiner to Augusta The Kennebec River Rail Trail

The Merrymeeting Trail would connect in Gardiner with the Kennebec River Rail Trail which extends through Farmingdale, Hallowell, and passes by Capital Park and the Statehouse and ends in downtown Augusta’s waterfront where the University of Maine at Augusta is relocating its art and architecture programs to a downtown facility very near to the trail. Augusta is also having its newly acquired Bond Brook Park turned in to a 17 mile Nordic center, mountain bike, and hiking facility.⁸ The Nordic facilities are so outstanding that Augusta will be offering a Nordic track that is on par with the recently built facilities for the Winter Olympics at Vancouver, British Columbia. Once completed Augusta hopes to have the Bond Brook trails connect with both the Kennebec River Rail Trail to its immediate south and to the campus of the University of Maine Augusta to its immediate north.

The Kennebec River Outstanding River Stretch and Historic Waterway

The Merrymeeting Trail will parallel in part the Kennebec River which over the past quarter century has been transformed from a heavily polluted river to one which is increasingly clean and beautiful. In 2009 American Rivers named Augusta, Maine as

t
.....
⁸ Augusta Trails and Central Maine New England Mountain Bike Association are two nonprofits working to advance this park and facility.
<http://webcache.googleusercontent.com/search?q=cache:2BRWOHy-ozQJwww.augustamaine.gov/index.asp%3FType%3DBASIC%26SEC%3D%257B9E26B069-3859-48F9-81FB-48D8BB33D6AB%257D+AUGUATA+TRAILS,+MAINE&cd=3&hl=en&ct=clnk&gl=us>

just one of eight communities nationally as a “water wise” community in recognition of the progress made in restoring the Kennebec River in this region.⁹ The Maine legislature has designated the section of the Kennebec through which both the Kennebec River Rail Trail and the Merrymeeting Trail extend as an “outstanding river” stretch.¹⁰ There are only 18 stretches of river in Maine to receive this designation.

This part of the Kennebec River has been designated by resolve in 2003 as the Kennebec River Historic Waterway.¹¹ The resolve directs the Department of Conservation to “integrate state land holdings and easements with municipal holdings and launches” and to “coordinate where possible with existing trails, historic sites and scenic opportunities.” The Department is also asked to “seek to identify funding sources and technical assistance that could help implement joint projects and strategies in connection with the waterway...” The proposed Merrymeeting Trail could act as the land based connector for the section of the trail extending from Gardiner south to Richmond.

Summary

As can be seen from the above review, the proposed Merrymeeting Trail warrants serious consideration by the Maine Department of Transportation to become the 4th trail in Maine to receive the designation as a trail of statewide significance. Since the Kennebec River Rail Trail would directly connect to the Merrymeeting Trail the two trails should be looked at as one trail connecting coastal Maine to the river communities along the Cathance and Kennebec Rivers and to the state capital. This combined trail of statewide significance, over 32 miles in length, would offer non motorized transportation to over 66,000 inhabitants within the eight communities and provide recreational opportunities to over 588,000 people who reside within a thirty mile range. The trail would be long enough and associated with so many other attractions that it would encourage travelers to visit the region, which in turn would stimulate economic growth, attracting new residents to live and work in this area. The Merrymeeting Trail and Kennebec River Rail Trails would be the first trail system of statewide significance to parallel a major river in Maine and would be the first trail system of statewide significance in Midcoast Maine.

t

⁹ <http://www.americanrivers.org/our-work/global-warming-and-rivers/infrastructure/natural-security-augusta.html>

<http://mdf.org/publications/Augusta-named-a-water-wise-community/165/>

¹⁰ <http://www.mainelegislature.org/legis/statutes/12/title12sec402.html>

¹¹ <http://www.legislature.maine.gov/legis/bills/121st/billtexts/LD068001-1.asp>