

# *Instruction Book*

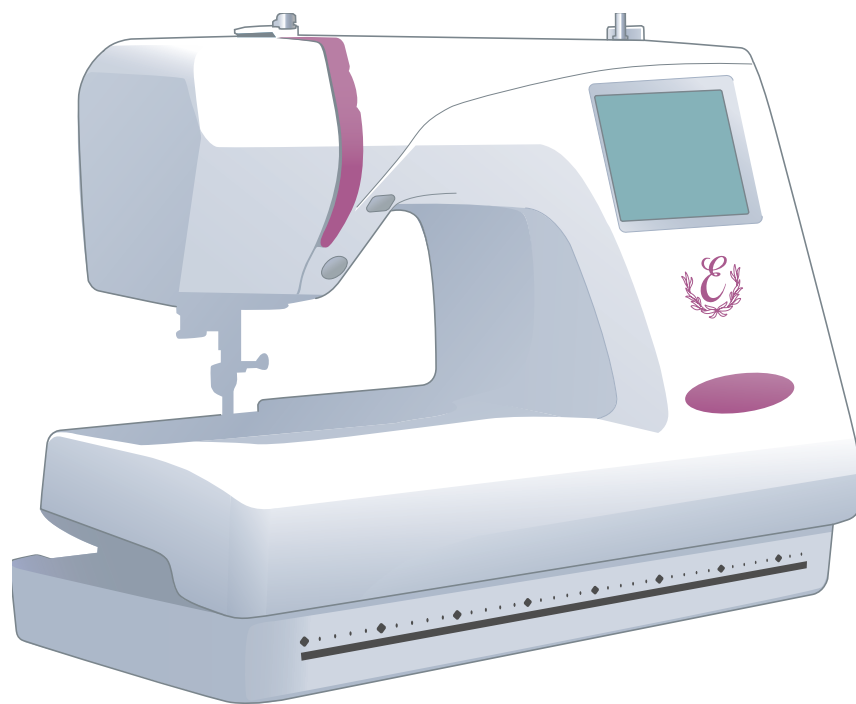

*Memory Craft 350e*

**JANOME**

# IMPORTANT SAFETY INSTRUCTIONS

This sewing machine is not a toy. Do not allow children to play with this machine.  
The machine is not intended for use by children or mentally infirm persons without proper supervision.

This sewing machine is designed and manufactured for household use only.

Read all instructions before using this sewing machine.

## **DANGER** — To reduce the risk of electric shock:

1. An appliance should never be left unattended when plugged in. Always unplug this sewing machine from the electric outlet immediately after using and before cleaning.
2. Always unplug before replacing a sewing machine bulb. Replace bulb with same type rated 12 Volts, 5 Watts.

## **WARNING** — To reduce the risk of burns, fire, electric shock, or injury to persons:

1. Do not allow children to play with the machine. The machine is not intended for use by children or infirmed persons without proper supervision.  
Do not allow to be used as a toy. Close attention is necessary when this sewing machine is used by or near children.
2. Use this appliance only for its intended use as described in this owner's manual.  
Use only attachments recommended by the manufacturer as contained in this owner's manual.
3. Never operate this sewing machine if it has a damaged cord or plug, if it is not working properly, if it has been dropped or damaged, or dropped into water.  
Return this sewing machine to the nearest authorized dealer or service center for examination, repair, electrical or mechanical adjustment.
4. Never operate the appliance with any air opening blocked. Keep ventilation openings of this sewing machine and foot controller free from accumulation of lint, dust and loose cloth.
5. Never drop or insert any object into any opening.
6. Do not use outdoors.
7. Do not operate where aerosol (spray) products are being used or where oxygen is being administered.
8. To disconnect, turn all controls to the off ("O") position, then remove plug from outlet.
9. Do not unplug by pulling on cord. To unplug, grasp the plug, not the cord.
10. Keep fingers away from all moving parts. Special care is required around the sewing machine needle.
11. Always use the proper needle plate. The wrong plate can cause the needle to break.
12. Do not use bent needles.
13. Do not pull or push fabric while stitching. It may deflect the needle causing it to break.
14. Switch this sewing machine off ("O") when making any adjustment in the needle area, such as threading the needle, changing the needle, threading the bobbin or changing the presser foot, and the like.
15. Always unplug this sewing machine from the electrical outlet when removing covers, lubricating, or when making any other adjustments mentioned in this owner's manual.

## **SAVE THESE INSTRUCTIONS**

The design and specifications are subject to change without a prior notice.



Please note that on disposal, this product must be safely recycled in accordance with relevant National legislation relating to electrical/electronic products. If in doubt please contact your retailer for guidance. (European Union only)

<b>KNOW YOUR MACHINE</b> .....	2-4
Names of Parts .....	2
Standard Accessories .....	3
Detachable Extension Table .....	4
<b>GETTING READY TO SEW</b> .....	5-18
Connecting the Power Supply .....	5
Start/Stop Button .....	5
AutoThread Cutter Button .....	5
Winding the Bobbin .....	6
Removing the bobbin .....	6
Setting the spool of thread .....	6
Additional spool pin .....	6
Winding the bobbin .....	7
Inserting the bobbin .....	8
Raising the Presser Foot .....	9
Threading the Machine .....	9
Needle Threader .....	11
Drawing up the Bobbin Thread .....	12
Adjusting the Thread Tension .....	13
Changing Needles .....	14
Embroidery Hoops .....	15
Templates .....	15
Stabilizers .....	16
Types of stabilizers .....	16
Usage .....	16
Setting the Fabric in an Embroidery Hoop .....	17
Attaching the Embroidery Hoop to the Machine .....	18
<b>KEY OPERATIONS</b> .....	19-25
Pattern Selection Window .....	19
Mode Setting .....	20
Machine Settings .....	21
Language Selection .....	24
On-screen Help .....	24
Selecting Built-in Designs .....	25-27
<b>EMBROIDERY SEWING</b> .....	28
Starting to Sew Embroidery .....	28
<b>MONOGRAMMING</b> .....	29-45
Monogram Selection Window .....	29-30
Monogram Embroidery .....	31-32
2-Letters Monogram .....	33
Correcting the Monogram .....	34
<b>OPTIONAL ITEMS</b> .....	35-36
PC Card .....	35
USB Memory .....	35
<b>EDITING MODE</b> .....	37-41
Editing the Embroidery Designs .....	38
<b>SAVING AFILE</b> .....	42-44
Creating a new file .....	43
Assigning the file name .....	43
Deleting the file .....	44
<b>CREATING AN ORIGINAL DESIGN</b> .....	45-46
<b>CARE AND MAINTENANCE</b> .....	47-48
Cleaning the Hook Race .....	47
Replacing the Light Bulb .....	48
Troubleshooting .....	49

## KNOW YOUR MACHINE

### Names of Parts

- ① Visual touch screen
- ② Bobbin winder spindle
- ③ Bobbin thread cutter
- ④ Spool holder (large)
- ⑤ Spool pin
- ⑥ Bobbin winding thread guide
- ⑦ Thread guide plate
- ⑧ Thread take-up lever
- ⑨ Thread tension dial
- ⑩ Face plate
- ⑪ Thread cutter & thread holder
- ⑫ Needle threader
- ⑬ Needle plate
- ⑭ Hook cover plate
- ⑮ Extension table (accessory box)
- ⑯ Hook cover plate release button
- ⑰ Start/stop button
- ⑱ Auto thread cutter button
- ⑲ Needle clamp screw
- ⑳ Needle
- ㉑ Embroidery foot

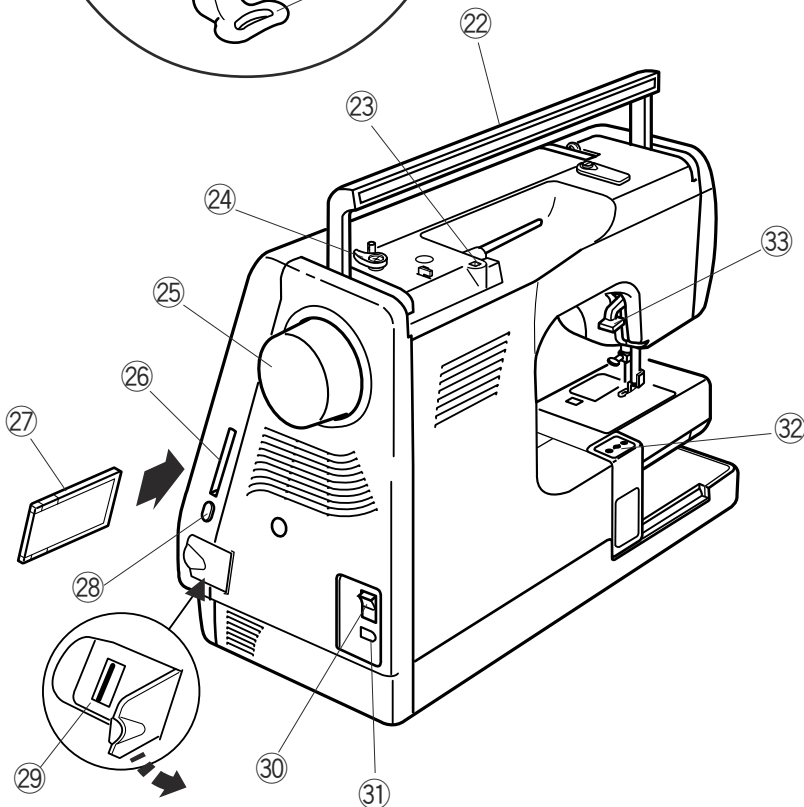
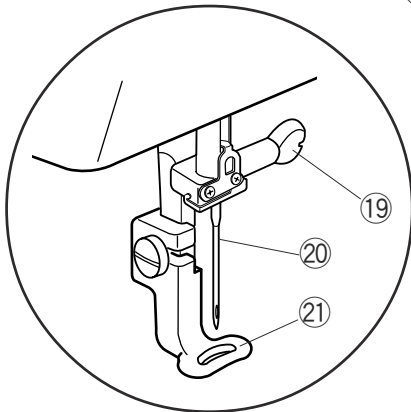
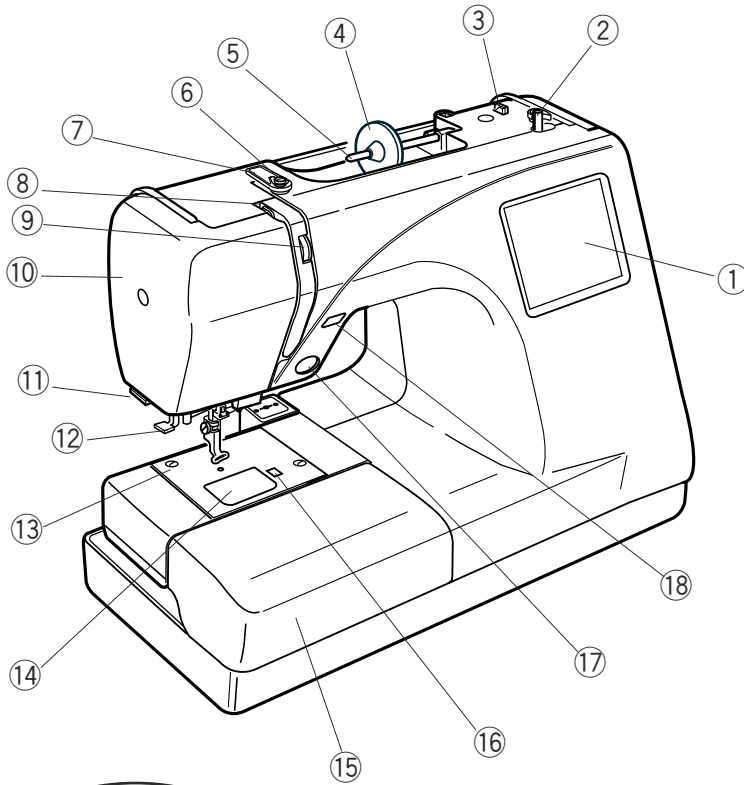

- ⑳ Carrying handle
- ㉑ Hole for additional spool pin
- ㉒ Bobbin winder stopper
- ㉓ Handwheel
- ㉔ PC card slot
- ㉕ PC card (optional item)
- ㉖ Card eject button
- ㉗ USB socket (for usb memory)
- ㉘ Power switch
- ㉙ Machine socket
- ㉚ Carriage (for embroidery)
- ㉛ Presser foot lifter

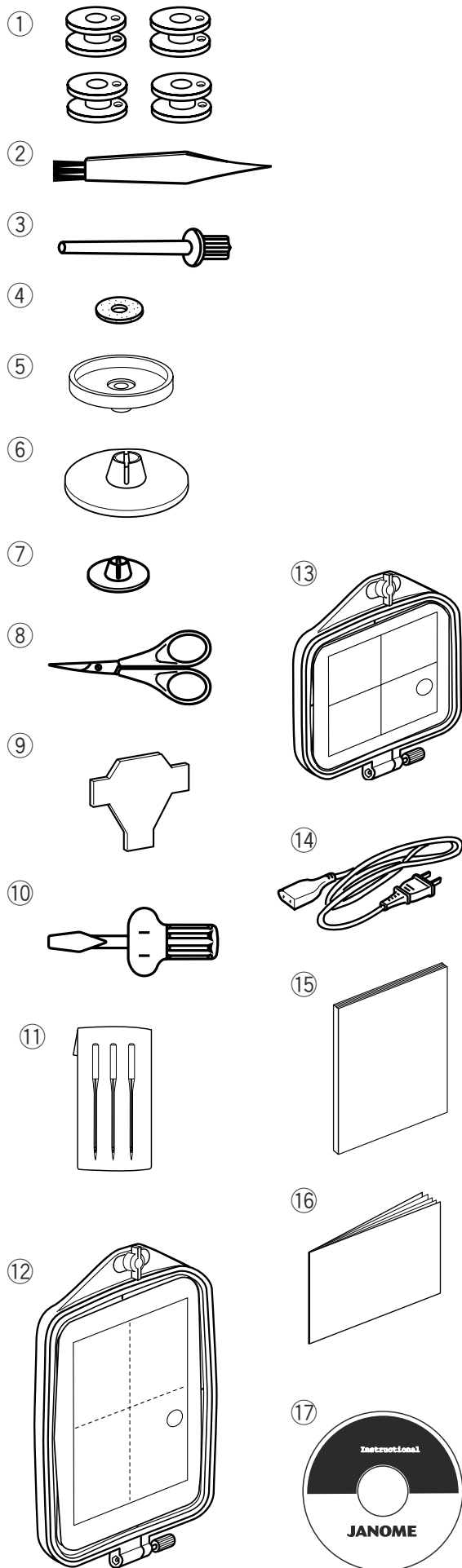

## Standard Accessories

- ① Bobbins
- ② Lint Brush
- ③ Additional Spool Pin
- ④ Spool Pin Felt
- ⑤ Spool Stand
- ⑥ Spool Holder (Large)
- ⑦ Spool Holder (Small)
- ⑧ Scissors
- ⑨ Screwdriver
- ⑩ Screwdriver
- ⑪ Set of Needles
- ⑫ Embroidery hoop B (with template)
- ⑬ Embroidery hoop A (with template)
- ⑭ Power Supply Cord
- ⑮ Instruction Book
- ⑯ Template Sheets (for Built-in Designs)
- ⑰ Instructional movie CD

## Detachable Extension Table

Detach the extension table when you use the optional Free arm hoop C.  
To remove, lift out the extension table toward you as illustrated.

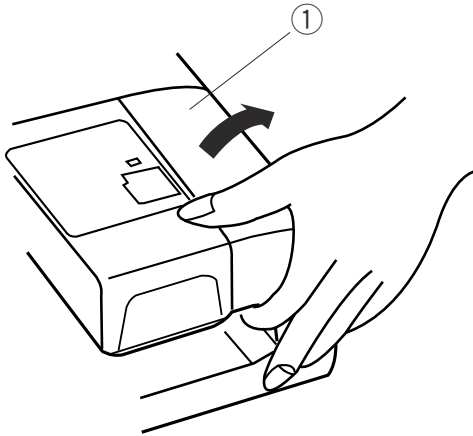

To attach, position the tabs on the base tab holes and push down gently.

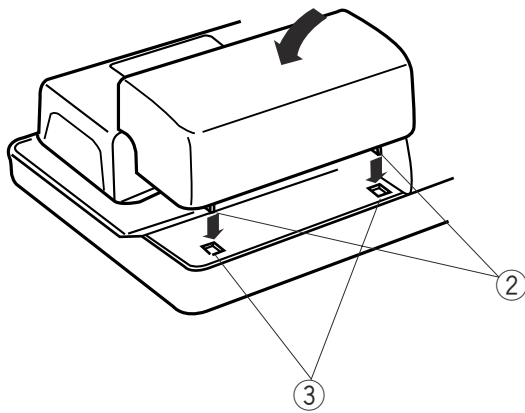

- ① Extension table
- ② Tabs
- ③ Base tab holes

Accessories are stored in the extension table.

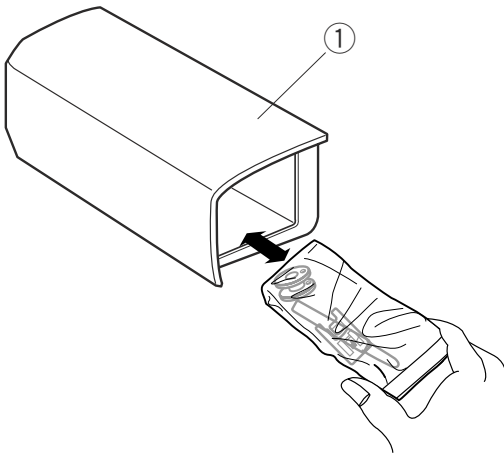

## GETTING READY TO SEW

### Connecting the Power Supply

Turn off the power switch and insert the machine plug into the machine socket. Insert the power supply plug into the wall outlet and turn the power switch on.

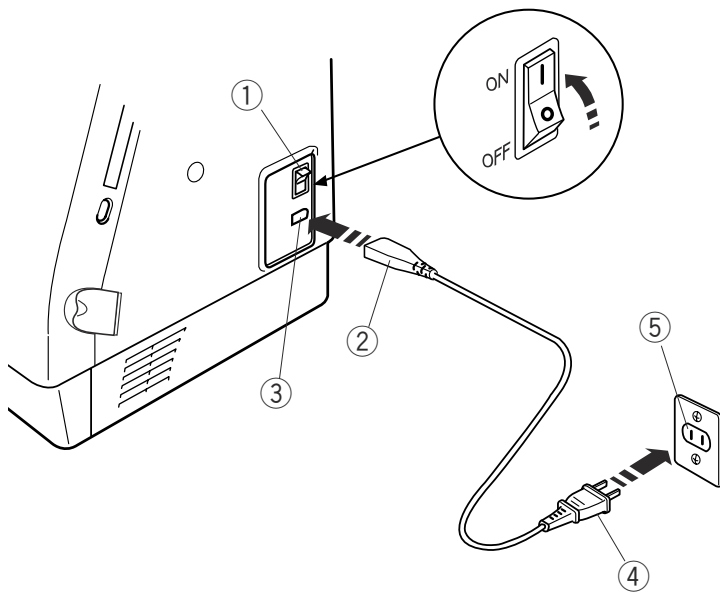

- ① Power switch
- ② Machine plug
- ③ Machine socket
- ④ Power supply plug
- ⑤ Wall outlet

#### NOTE:

After turning on the power, it takes approximately six seconds for the pattern selection window to be displayed on the visual touch screen. (This is the required boot up time and is not a defect)

#### Operating Instructions:

“The symbol "O" of a switch indicates the "off" position of a switch.”

“For appliances with a polarized plug (one blade wider than the other). To reduce the risk of electric shock, this plug is intended to fit in a polarized outlet only one way. If it does not fit fully in the outlet, reverse the plug. If it still does not fit, contact a qualified electrician to install the proper outlet. Do not modify the plug in any way.” (for the USA and Canada only)

#### For Your Safety:

While in operation, always keep your eyes on the sewing area, and do not touch any moving parts such as the thread take-up lever, handwheel or needle.

Always turn off the power switch and unplug the power supply:

- when leaving the machine unattended.
- when attaching or removing parts.
- when cleaning the machine.

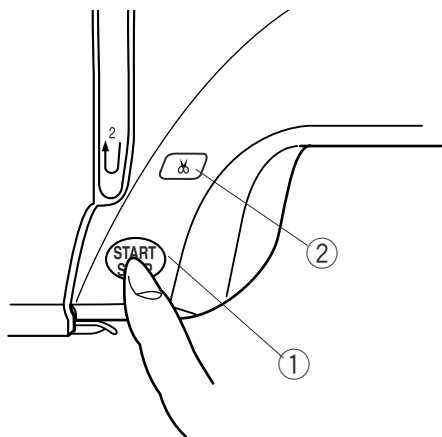

#### Start/Stop Button

Press this button to start or to stop the machine. The color of the button changes each time you press it—red when the machine is running, and green when it is stopped.

- ① Start/stop button

#### NOTE:

The Memory Craft 350E is equipped with an automatic shutdown safety feature to prevent overheating when the machine is running overloaded. Follow safety instructions that appear on the visual touch screen if it happens.

#### Auto Thread Cutter Button

Press this button to trim the threads after sewing is finished (refer to page 28).

- ② Auto thread cutter button

## Winding the Bobbin

### Removing the bobbin

Slide the hook cover plate release button to the right, and remove the hook cover plate. Lift out the bobbin from the bobbin holder.

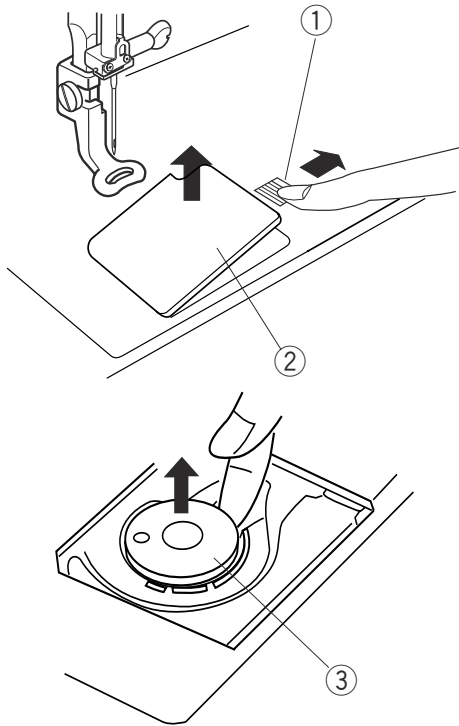

- ① Hook cover plate release button
- ② Hook cover plate
- ③ Bobbin

### Setting the spool of thread

Place the spool of thread on the spool pin with the thread coming off the spool as shown. Attach the large spool holder, and press it firmly against the spool of thread.

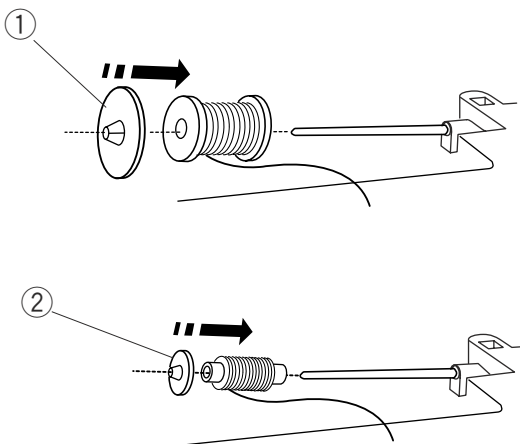

#### NOTE:

Use the small spool holder to hold narrow or small spools of thread.

- ① Large spool holder
- ② Small spool holder

### Additional spool pin

Use the additional spool pin when you need to wind the bobbin without unthreading the machine while working on a sewing project.

Insert the additional spool pin into the spool stand then into the hole besides the horizontal spool pin.

Place the felt on the spool pin and place a spool of thread on it as shown.

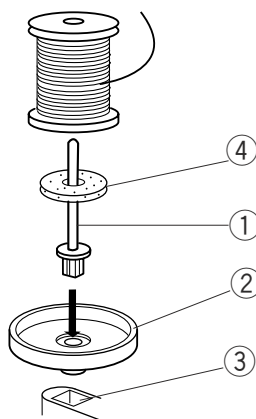

- ① Additional spool pin
- ② Spool stand
- ③ Hole
- ④ Felt



## Winding the bobbin

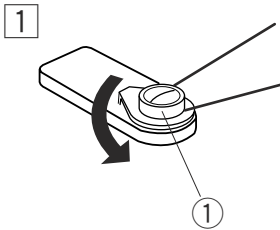
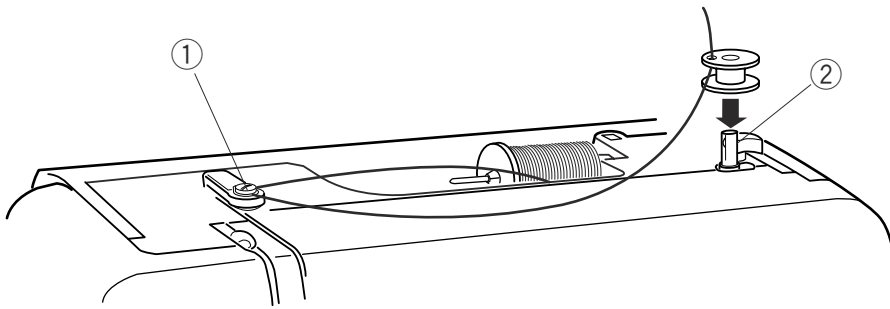

- 1 Guide the thread around the bobbin winder thread guide while holding the thread at the spool.

① Bobbin winder thread guide

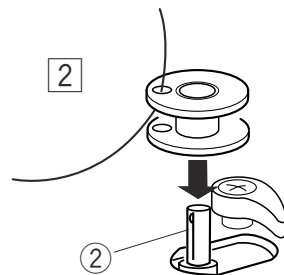

- 2 Thread through the hole in the bobbin from the inside to the outside. Put the bobbin on the bobbin winder spindle.

② Bobbin winder spindle

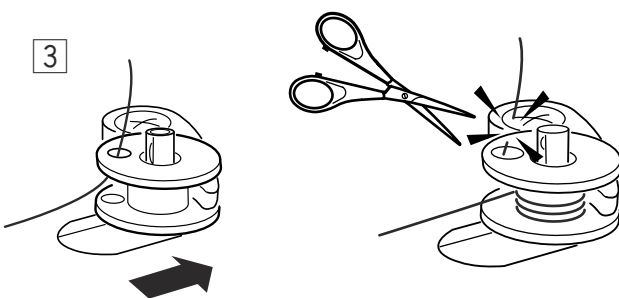

- 3 Push the spindle to the right. Press the Start/Stop button while holding the end of the thread. Stop the machine after the bobbin has made a few turns. Cut the thread close to the hole in the bobbin.

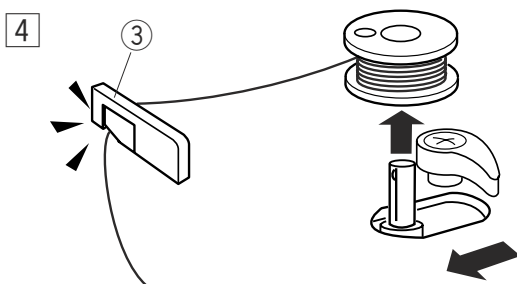

- 4 Press the Start/Stop button again. When the bobbin is fully wound it will stop automatically. Press the Start/Stop button to stop the machine then return the bobbin winder spindle to the left. Remove the bobbin and cut the thread with the bobbin thread cutter.

③ Bobbin thread cutter

### NOTES:

Do not move the bobbin winder spindle while the machine is running.

For safety purposes, the motor will stop automatically after running for two minutes.

## Inserting the bobbin

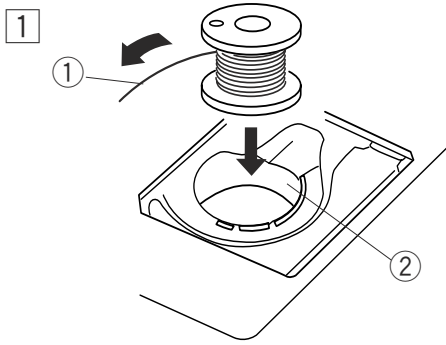

- 1 Place the Bobbin in the Bobbin Holder with the thread running off in the counterclockwise direction.

- ① Thread
- ② Bobbin holder

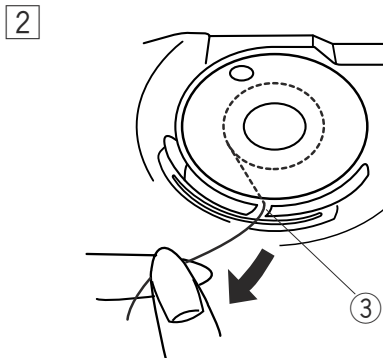

- 2 Guide the thread into front notch on the front of the bobbin holder. Draw the thread to the left, sliding it between the tension spring blades.

- ③ Front notch

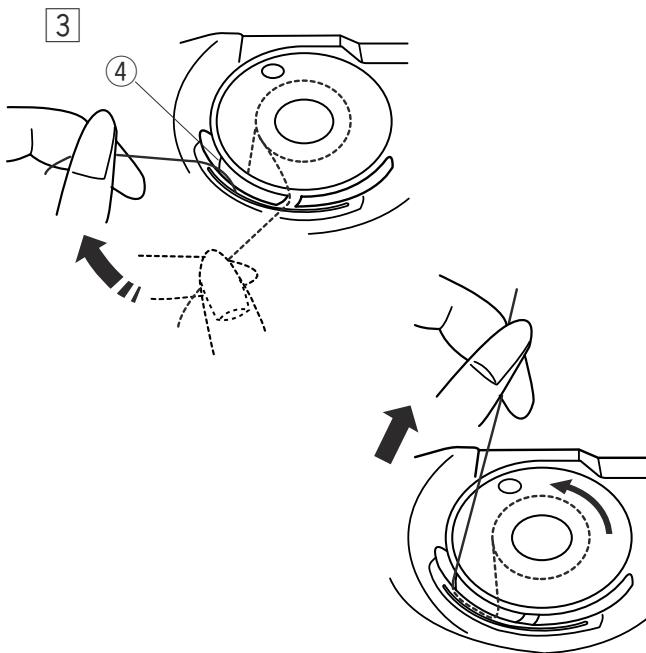

- 3 Continue to draw the thread lightly until the thread slips into side notch. Pull out about 10 cm (4") of thread to the rear.

- ④ Side notch

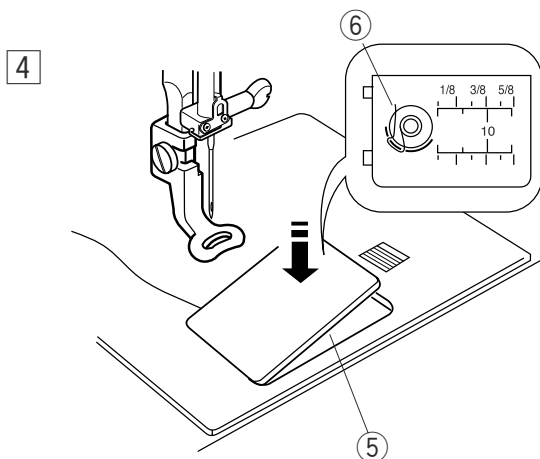

- 4 Refer to the threading chart shown on the hook cover plate. Reattach the hook cover plate.

- ⑤ Hook cover plate
- ⑥ Threading chart

## Raising the Presser Foot

The presser foot lifter raises and lowers the presser foot. You can raise the presser foot about 6 mm (1/4") higher than the normal up position by exerting more pressure when lifting the presser foot lifter.

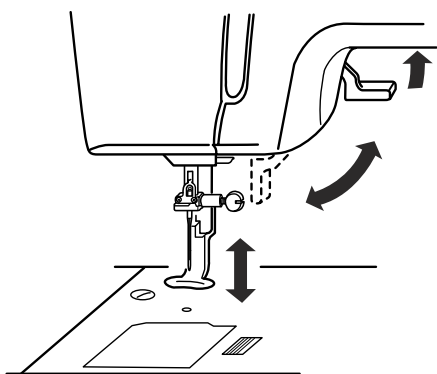

## Threading the Machine

1 Raise the presser foot lifter. Turn the handwheel to bring the needle to its highest position. Draw the thread around and under the thread guide while holding the thread at the spool. Then draw the thread down through the right channel of the thread guide plate.

- ① Presser foot lifter
- ② Thread guide

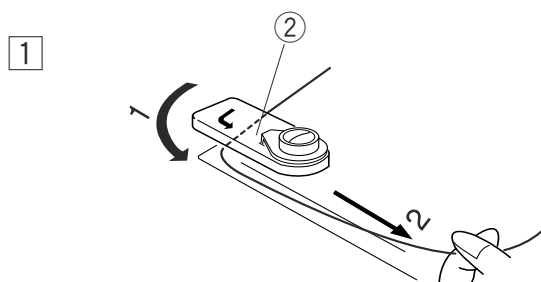
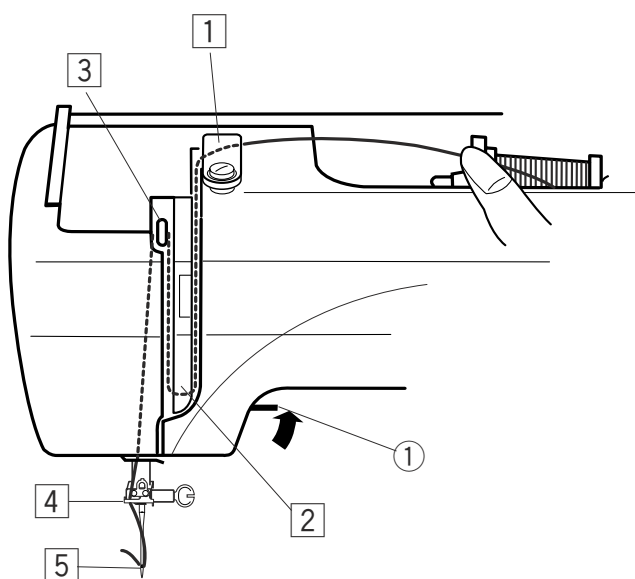

2 Firmly draw the thread around the thread guide plate and up to the thread take-up lever.

- ③ Thread guide plate

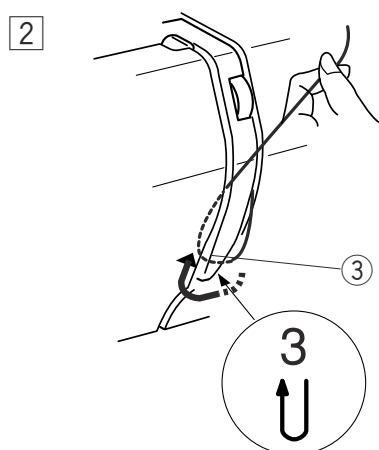

3

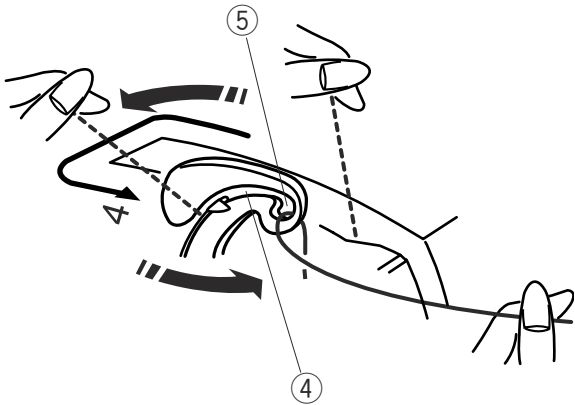

3 Slip the thread through the slit and down into the eye of the take-up lever as shown. Draw the thread down through the left channel.

- 4 Slit
- 5 Eye of the take-up lever

4 5

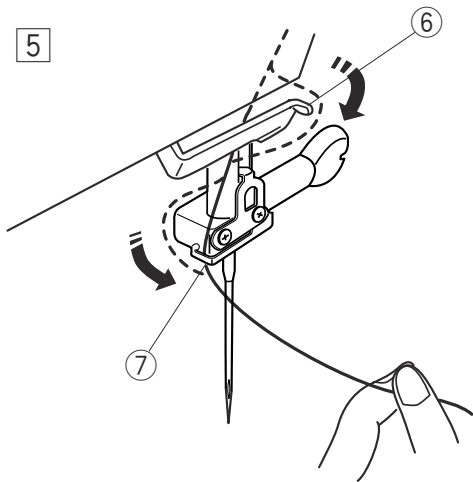

4 Slip the thread behind the lower thread guide from the right.

6 Lower thread guide

5 Slip the thread in the needle bar thread guide from the left.

7 Needle bar thread guide

Thread the needle from front to back by hand or use the built-in needle threader.

**NOTE:**  
Refer to page 11 for built-in needle threader

## Needle Threader

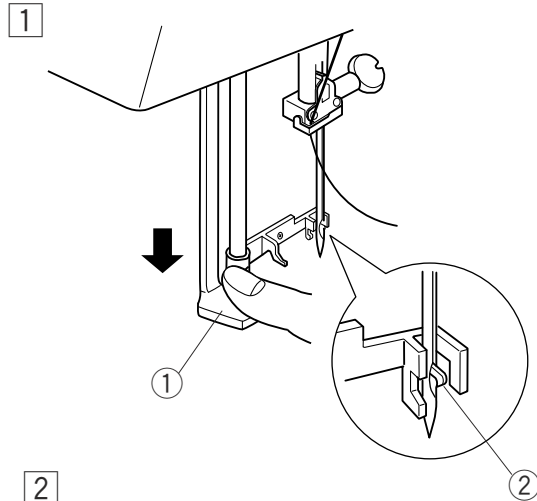

- 1 Lower the presser foot. Depress the needle threader knob as far as it will go. The hook comes out through the needle eye from behind.

- ① Needle threader knob
- ② Hook

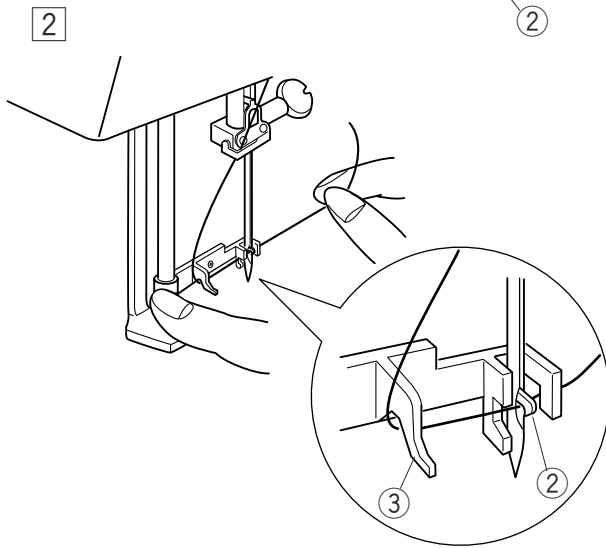

- 2 Draw the thread down around the threader guide and under the hook.

- ③ Threader guide

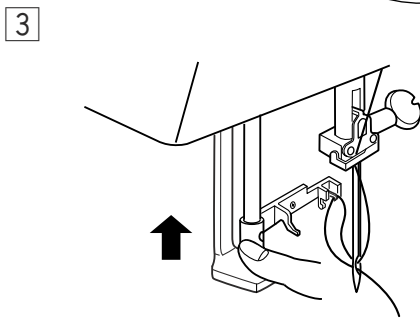

- 3 Release the threader knob slowly while holding the thread end with your hand. A loop of the thread is pulled up through the needle eye.

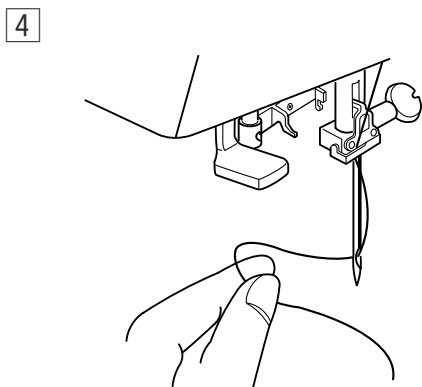

- 4 Remove the loop from the threader and pull out the thread end from the needle eye.

### NOTES:

The needle threader works well with the threads #50-90 and needles #11-16, the blue tipped needle as well.

If the needle stops too low to use the needle threader after the automatic thread cutting, raise the needle to its highest position by turning the handwheel.

## Drawing up the Bobbin Thread

1

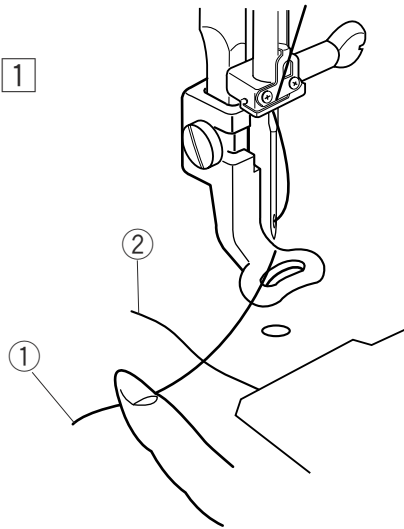

- 1 Raise the presser foot lifter. Hold the needle thread with your finger.

- ① Needle thread
- ② Bobbin thread

2

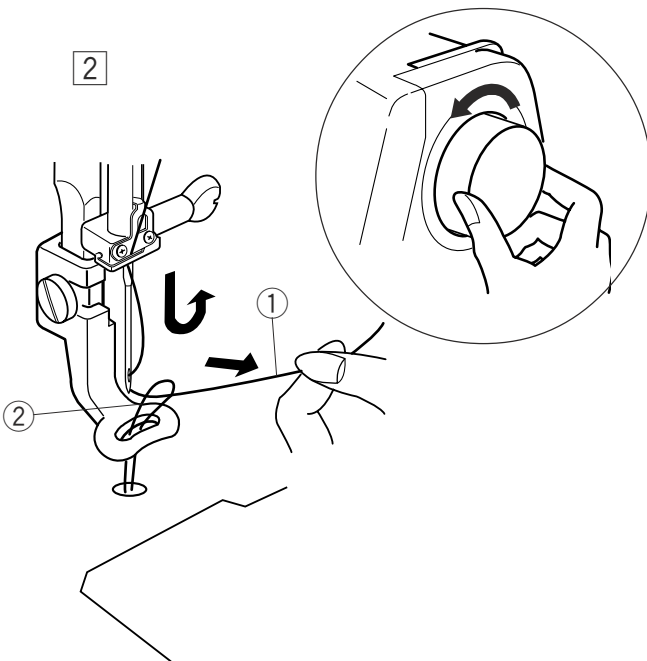

- 2 Turn the handwheel one complete turn toward you. Draw the needle thread to bring up a loop of the bobbin thread.

3

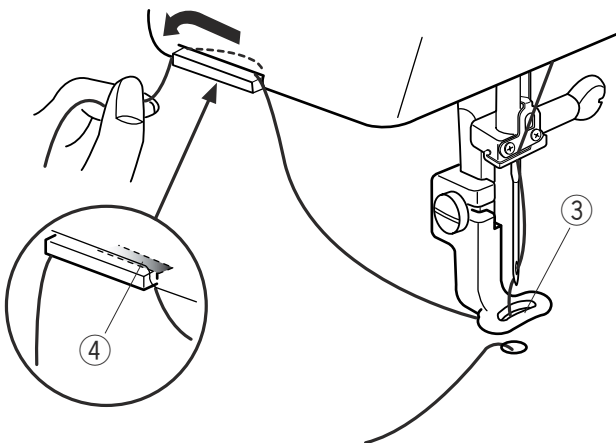

- 3 Pass the needle thread through the hole in the embroidery foot and draw it up to the thread holder leaving an inch of free thread.

- ③ Hole
- ④ Thread holder

## Adjusting the Thread Tension



### Balanced thread tension:

Small amount of the needle thread shows on the wrong side of the fabric.

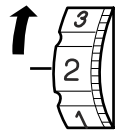

### When the needle thread tension is too tight:

The bobbin thread shows on the right side of the fabric. Reduce the tension by turning the tension dial to a lower number.

① Bobbin thread

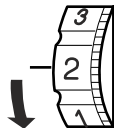

### When the needle tension is too loose:

The needle thread forms loops and the stitches look shaggy. Increase the tension by turning the dial to a higher number.

## Changing Needle

Turn off the power switch. Raise the needle by turning the handwheel and lower the presser foot. Loosen the needle clamp screw by turning it counterclockwise. Remove the needle from the clamp.

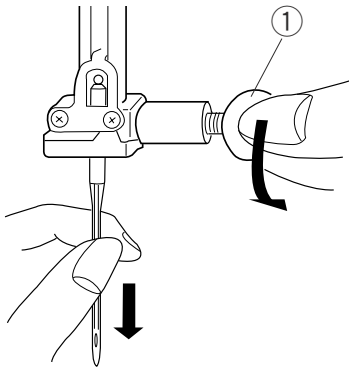

Insert a new needle into the needle clamp with the flat side of the needle to the rear.

- ① Needle clamp screw
- ② Flat side of the needle

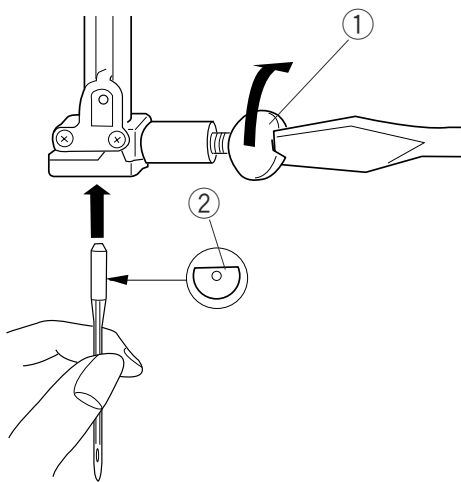

When inserting the needle into the needle clamp, push it up as far as it will go and tighten the needle clamp screw firmly.

To check needle straightness, place the flat side of the needle onto something flat (a needle plate, glass etc.) The gap between the needle and the flat surface should be consistent.

- ③ Gap

Never use a blunt needle.

### NOTES:

Use the size 11 Blue Tipped Needles for fine fabrics. For medium to heavy weight fabrics, use the size 14 needles.

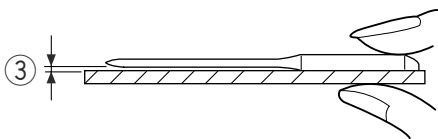



## Embroidery Hoops

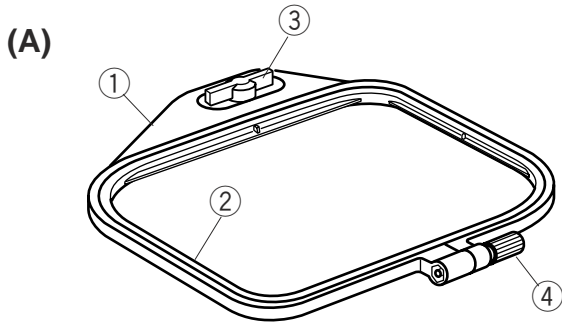

### (A) Embroidery Hoop A:

This is the standard size hoop, with a 12.6 cm (5") by 11 cm (4 3/8") embroidery area for sewing PC Card embroidery designs etc.

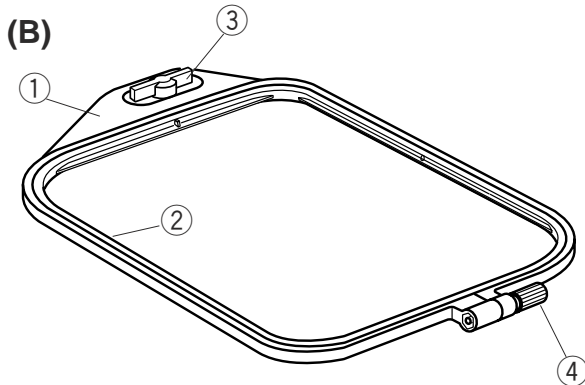

### (B) Embroidery Hoop B:

This is the large-size hoop, with a 20 cm (8") by 14 cm (5 1/2") embroidery area for sewing large-size designs and combined designs.

- ① Outer hoop
- ② Inner hoop
- ③ Attaching knob
- ④ Hoop tightening screw

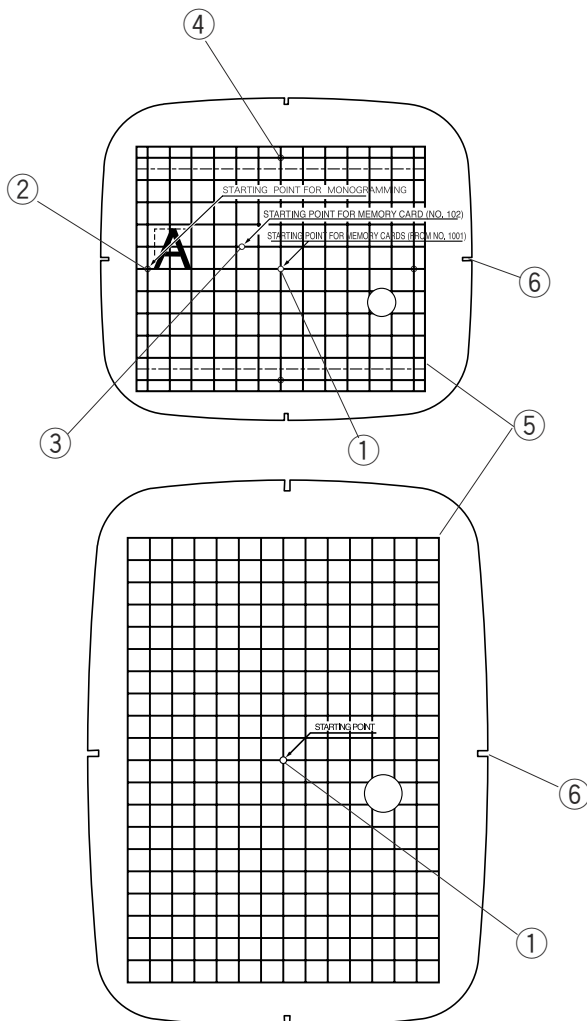

## Templates

When positioning the fabric into the hoop, use the template to align the centerlines on the fabric with the center of the hoop. First mark the centerlines on the fabric and place the fabric on the outer hoop. Place the inner hoop and template over the fabric and adjust the fabric placement.

- ① Starting point for built-in and PC Card designs
- ② Starting point for monogramming in horizontal placement
- ③ Starting point for Memory Card No. 102 and up for Memory Craft 5700/9000.
- ④ Starting point for monogramming in vertical placement
- ⑤ Embroidery boundary for built-in and PC Card designs.

### NOTE:

The four indentations on the template do not correspond with reference lines.

- ⑥ Indentations for positioning the template

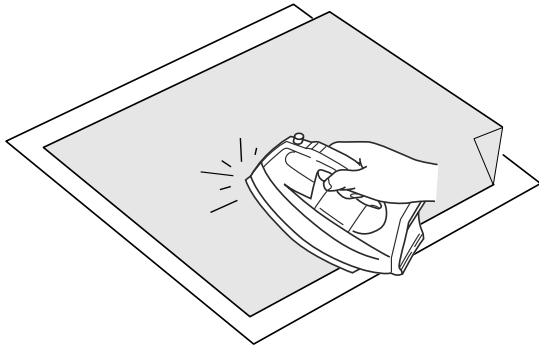

### **Adhesive (Iron-on) Stabilizer**

Place the Wrong side of fabric and the glossy side of the stabilizer together. Fold up a corner of the stabilizer and fuse it with an iron.

#### **NOTES:**

- Fold up a corner of the stabilizer, to make it easier to peel off the excess stabilizer after stitching.
- Ironing temperatures vary depending on kind of adhesive type stabilizer.

## **StabilizerS**

To obtain the best quality embroidery, it is important to use stabilizers.

### **Types of stabilizer**

Tear-away Stabilizer is made from a fiber that will tear easily. Use tear-away stabilizers for stable woven fabrics. After stitching, tear away the stabilizer so that the small portion left in the back of the stitching will not affect the wear.

Iron-on Stabilizer is an adhesive type stabilizer for knits and all kinds of unstable fabrics. Fuse it to the wrong side of the fabrics with an iron.

Cut-away Stabilizer is a non-woven fabric that does not tear. Cut the excess portion after stitching. Use cutaway

stabilizers for knits and all kinds of unstable fabrics.

Water Soluble Stabilizer will dissolve in water. Use this stabilizer for cutwork or lace embroidery, and also for the right side of looped fabrics such as towel to avoid loops coming through the embroidery.

Sticky Stabilizer is a sticky paper used for securing a small fabric or work that cannot be secured in the hoop.

It is also used for velvet and other napped fabric that would be permanently marked by the hoop.

### **Usage:**

- The stabilizer should be attached to the wrong side of fabric.
- More than one layer may be required.
- Felt or stable fabrics do not need to be stabilized and you may embroider directly on it.
- For firm fabrics, you may place a thin paper under the fabric.
- The non-adhesive type should be used when embroidering fabric, which cannot be ironed or for sections, which are difficult to iron.
- Cut the stabilizer larger than the embroidery hoop and set it on the hoop so that the entire piece is fastened with the hoop to prevent looseness of the fabric.

## Setting the Fabric in an Embroidery Hoop

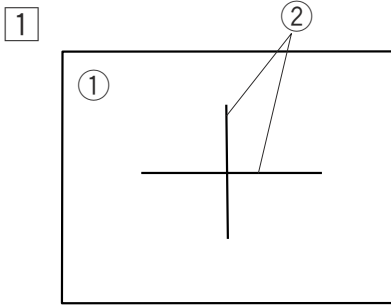

- 1 Mark the centerlines on the right side of the fabric with tailor's chalk.

- ① Fabric
- ② Centerlines

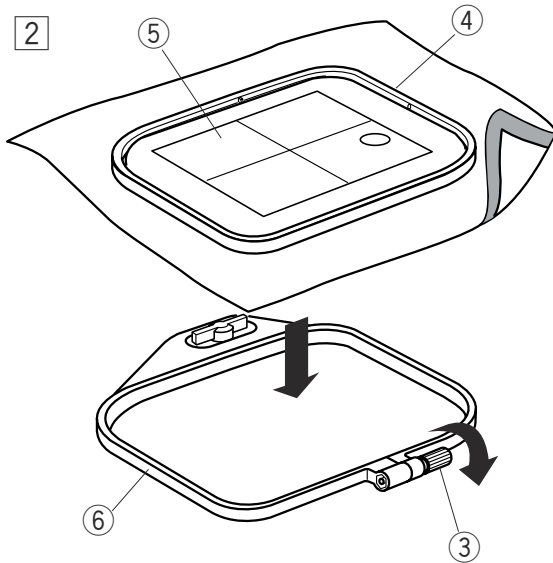

- 2 Loosen the hoop tightening screw of the outer hoop and lay the fabric and the inner hoop over the outer hoop. Place the template over the fabric, matching centerlines.

- ③ Hoop tightening screw
- ④ Inner hoop
- ⑤ Template

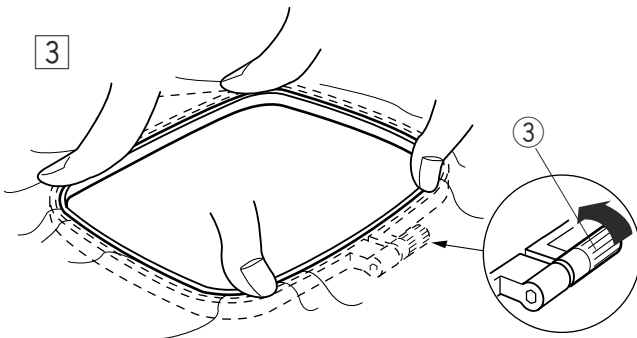

- 3 Set the inner hoop into the outer hoop and tighten the hoop tightening screw.

- ⑥ Outer hoop

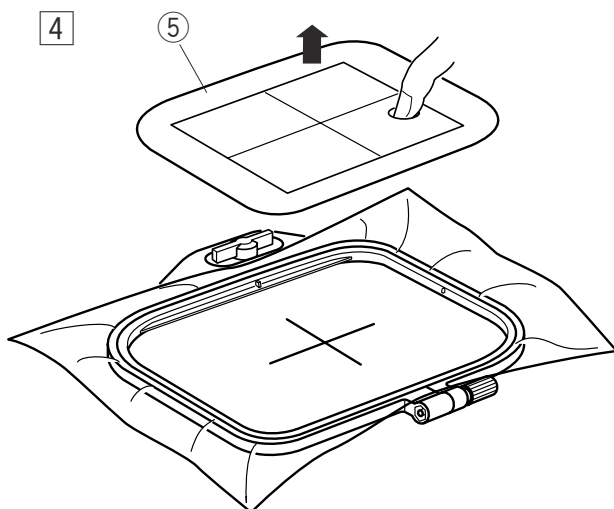

- 4 Remove the template.

### NOTES:

When placing the fabric on the embroidery hoop, place the outer hoop on a flat surface. For thin and stretchy fabrics, use an adhesive type stabilizer (iron-on type) on the wrong side of the fabric. More than one layer of the stabilizer may be required.

The Cloth Setter 10000 (optional Item) is very helpful when setting a fabric to a hoop in the right position.

## Attaching the Embroidery Hoop to the Machine

Turn the attaching knob so it is parallel with the hoop, and set it on the carriage. Attach the hoop by fitting the pins into the carriage holes.

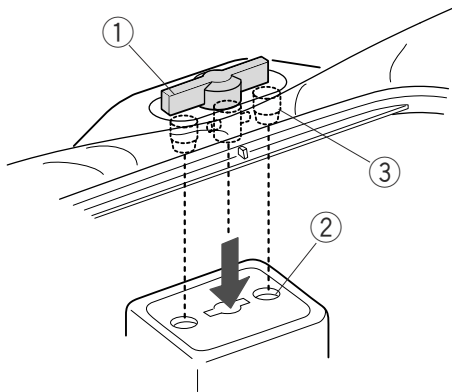

- ① Attaching knob
- ② Carriage holes
- ③ Pins

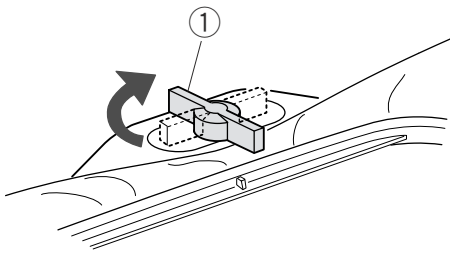

Turn the attaching knob clockwise.

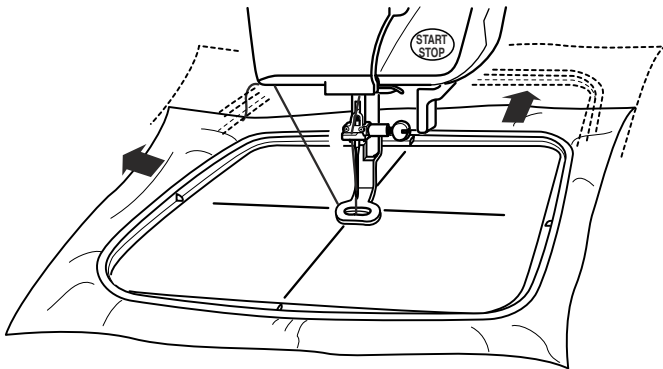

### **! CAUTION:**

Always provide sufficient clearance for the embroidery carriage behind your machine before starting the machine.

Never try to move the carriage by hand or touch the carriage while it is moving.

Make sure to return the carriage to the home position before turning the power off.

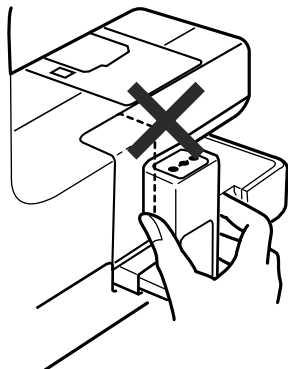

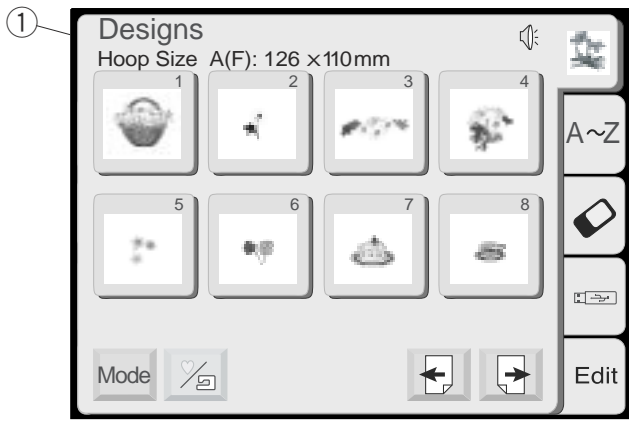

## KEY OPERATIONS

### Pattern Selection Window

When the machine is turned on, the pattern selection window of the built-in design appears on the visual touch screen.

**NOTE:**

After turning on the power, it takes approximately six seconds for the pattern selection window to be displayed on the visual touch screen.  
(This is the required boot up time and is not a defect)

The following 5 categories are available in the pattern selection window:



**① Built-in designs**

There are 100 ready-to-sew designs available in this category.  
You can also open design files saved in the internal memory.

**② Monogramming**

You can sew three styles of lettering (Gothic, Script and Cheltenham), as well as 3-letter and 2-letter monogramming.



**③ PC card**

You can sew embroidery designs from the optional PC Design cards as well as your favorite designs stored in the Compact flash (optional item).

**④ USB memory**

You can save and open embroidery design files stored in the USB memory (optional item).

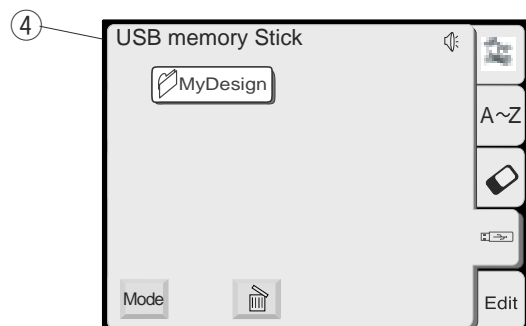

**⑤ Editing**

The editing function allows you to modify and combine the embroidery designs from various sources.

Press the tab of the desired category to open the appropriate window.

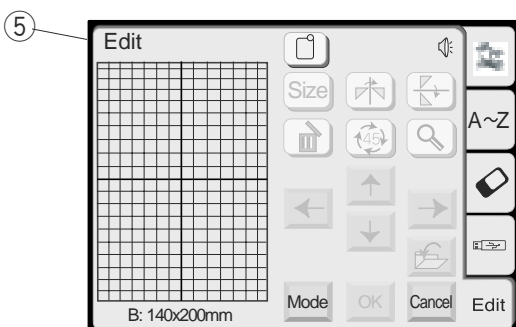

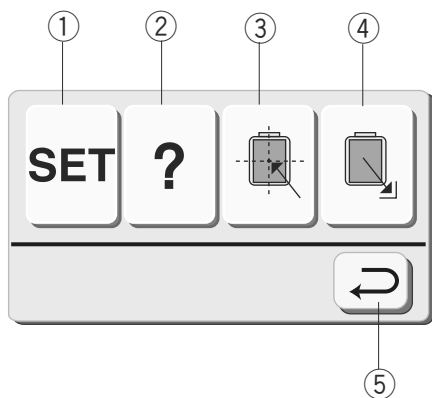
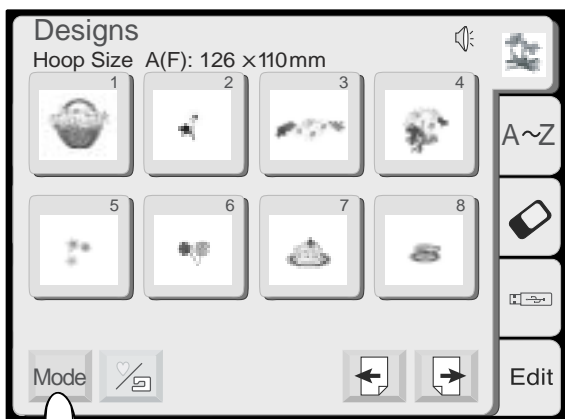

## Mode Setting

Press the Mode key and the mode selection dialog box will open.

Press one of the following keys to select the desired operation.

### ① SET key

Press this key to open the machine setting window. You can customize the machine settings to suit your preference.

### ② Help key

Press this key to view the help topics for basic operations.

### ③ Carriage centering key

Press this key to move the carriage to the center position (starting point for embroidery).

### ④ Return carriage key

Press this key to bring the carriage back to its stored position after finishing embroidery.

### ⑤ Return key

Press this key to close the mode selection dialog box and return to the previous screen.

#### NOTE:

Before you turn the power switch OFF in Embroidery Mode, always be sure to press the return carriage key to return the carriage to its stored position.

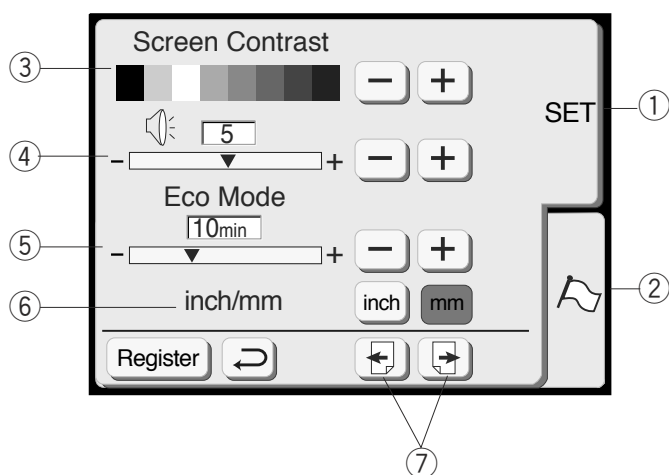
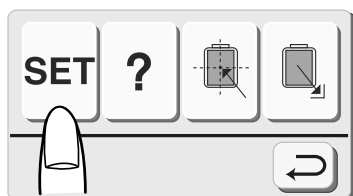

## Machine Settings

Pressing the **SET** key will open the machine setting dialog box.

### ① SET tab

Press the **SET** tab to customize the machine settings.

### ② Flag tab (Language selection tab)

Press the **Flag** tab to select the language for the screen display. You can select one of 11 languages.

### ③ Screen contrast

The visual touch screen contrast can be adjusted. Press the **Plus** **+** key, to sharpen the screen contrast. Press the **Minus** **-** key, to fade the screen contrast.

### ④ Sound control

The buzzer volume can be adjusted. The volume level can be set from (0 to 10) and the default setting is 5. Press the **Plus** **+** key, to increase the buzzer volume. Press the **Minus** **-** key, to decrease the buzzer volume.

When you select 0 the buzzer turns off.

### ⑤ Eco mode

After turning on the power switch, if you have not used the machine, after a while, the machine will enter Eco Mode. The visual touch screen will go dark and the sewing light will turn off.

Whenever you touch the screen while the machine is in Eco mode, the screen and sewing light will turn on again.

You can set the Eco mode timer from 1 minute to 30 minutes. The default setting is 10 minutes.

### To set the Eco Mode timer:

Press the **Plus** **+** key to increase the timer setting. Press the **Minus** **-** key to decrease the timer setting.

To turn off the Eco mode, Press the **Plus** **+** key until **"OFF"** shows in the box.

### ⑥ Inch/Millimeter

You can set your machine's measuring unit to either inch or millimeter depending upon your preference. The default unit setting is millimeter.

Press the **inch** or **mm** key to select the unit you preferred.

### ⑦ Page key

You can turn the pages by pressing the page keys. Press the **Next page** **→** key to view the next page. Press the **Previous page** **←** key to view the previous page.

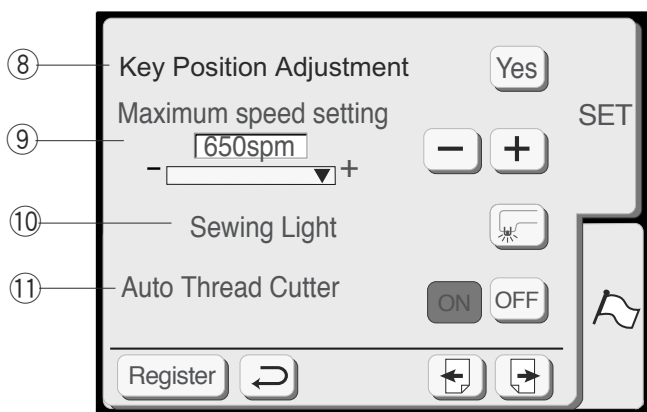

### ⑧ Key position adjustment

If you think the touch panel keys are out of alignment, you can correct it in the key position adjustment window.

When you press the **Yes** key, the window (A) will be shown. With your finger, press the **Black cross (+)** signs as they appear in order. When you press the last **Black cross (+)** sign, the window (B) will be shown.

### ⑨ Embroidery maximum speed

The maximum sewing speed can be changed from 400 to 650 spm for embroidery sewing. The default setting is 650 spm.

Press the **Minus** key to reduce the maximum sewing speed.

Press the **Plus** key to increase the maximum sewing speed.

#### NOTE:

Reduce the sewing speed when sewing patterns with narrow zigzag stitches that tend to deform at the high speed.

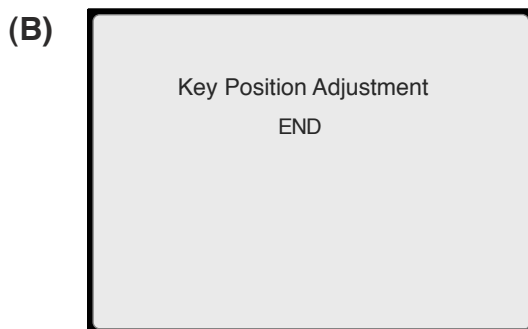
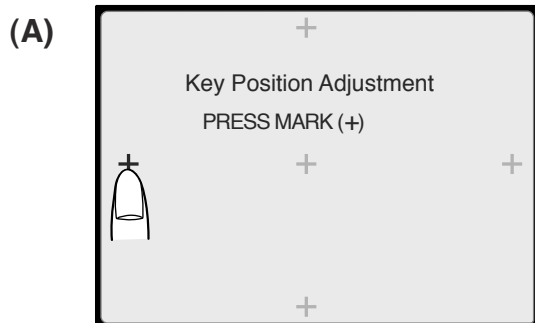

### ⑩ Sewing light

You can turn the sewing light on or off by pressing the **Sewing light** key.

### ⑪ Auto thread cutter

If the auto thread cutter command is enabled, the machine will stop and cut the threads automatically when each color section is finished.

Press the **ON** key to enable auto thread cutter. Press the **OFF** key to disable auto thread cutter.

Press the next page key to view the next page.



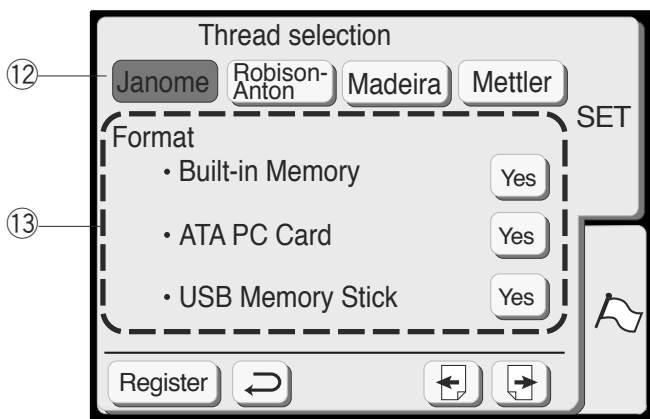

⑫ **Thread selection**  
There are four brands of embroidery threads to choose from. Press the corresponding key of the thread you wish to use. The color code of the selected brand will be shown in the embroidery screen.

⑬ **Formatting the built-in memory**  
If the internal memory, ATA PC card or USB memory does not function due to damage to the memory bank, you need to re-enable it by formatting the memory.

To format the memory press the **Yes** Yes key next to the memory location.

**NOTE:**  
Formatting will erase all data stored in the memory.

Press the next page key to view the next page.

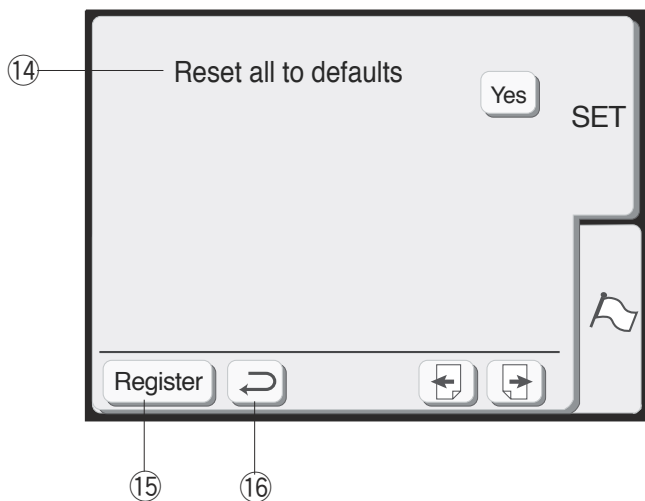

⑭ **Reset all to default**  
Pressing the **Yes** Yes key will return all settings except for language to defaults (the same settings as when you purchased the machine).

⑮ **Register key**  
Press this key to register the settings and return to the previous screen.

⑯ **Return key**  
Press this key to return to the previous screen without registering the settings.

## Language Selection

You can select one of the following 11 languages by pressing the corresponding key.

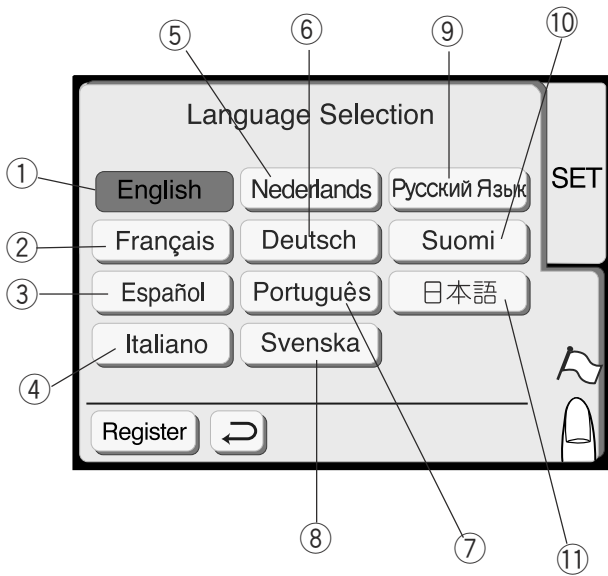

- ① English
- ② French
- ③ Spanish
- ④ Italian
- ⑤ Dutch
- ⑥ German
- ⑦ Portuguese
- ⑧ Swedish
- ⑨ Russian
- ⑩ Finnish
- ⑪ Japanese

Press the register key to confirm your selection.

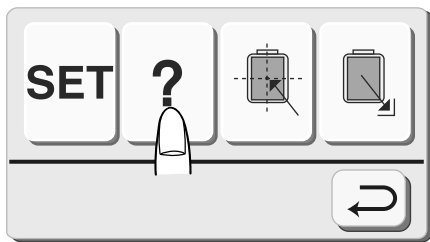

## On-screen Help

You can view on-screen help for the basic operations of the machine.

Press the **Help** (?) key and the help index window will open.

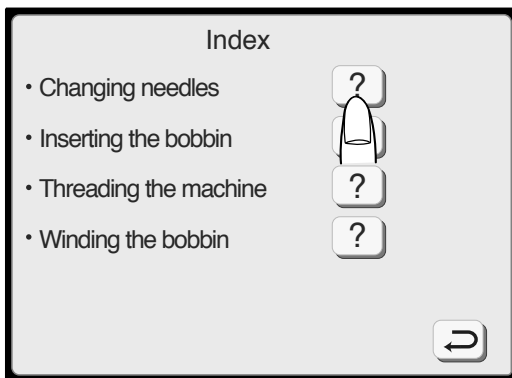

Press the (?) key next to the help topic you wish to view.

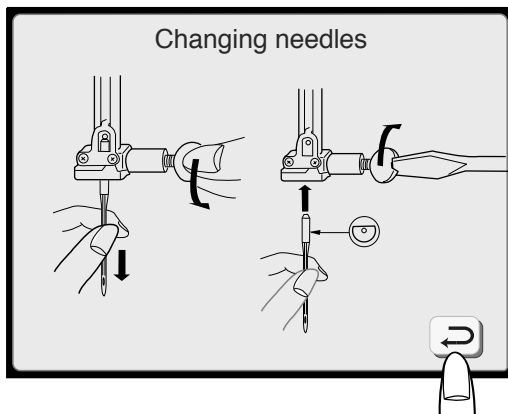

The illustrated help of the selected topic will be displayed on the screen.

**NOTE:**  
Press the **Return** (↩) key to go back to the previous screen.

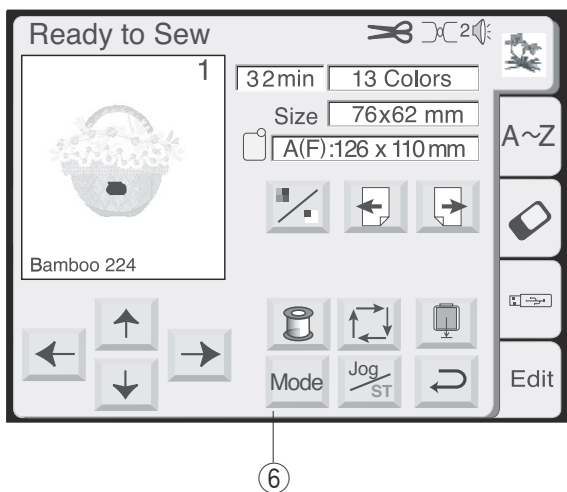
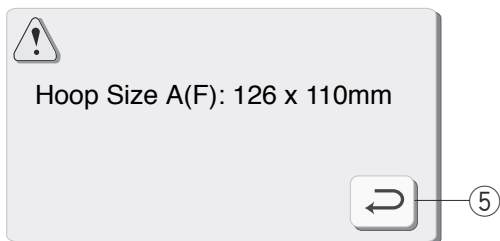
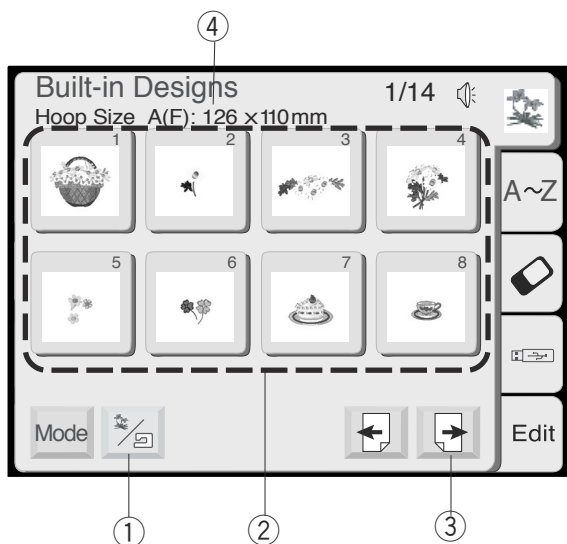

## Selecting Built-in Designs

The pattern selection window for the built-in designs will appear when the machine is turned on.

There are 100 ready-to-sew designs available in this category.

You can also open design files saved in the internal memory.

Press the **Built-in/Saved**  key to switch between the built-in designs and saved designs.

- ① Built-in/Saved key

To select the embroidery design, press the desired pattern selection key.

- ② Pattern selection keys

Press the **Next page** key to display the designs on the following pages.

There are 14 pages of designs grouped by the hoop size.

- ③ Next page key
- ④ Hoop size

When you press the **Pattern selection** key, the screen will show a message advising you the hoop to be used. Press the **Return** key and the **Ready to Sew** screen will open.

- ⑤ Return key
- ⑥ Ready to Sew screen

## Ready to Sew screen (continued)

A stitch image of the selected design and function keys as well as information of the selected design are indicated in the **Ready to Sew** screen.

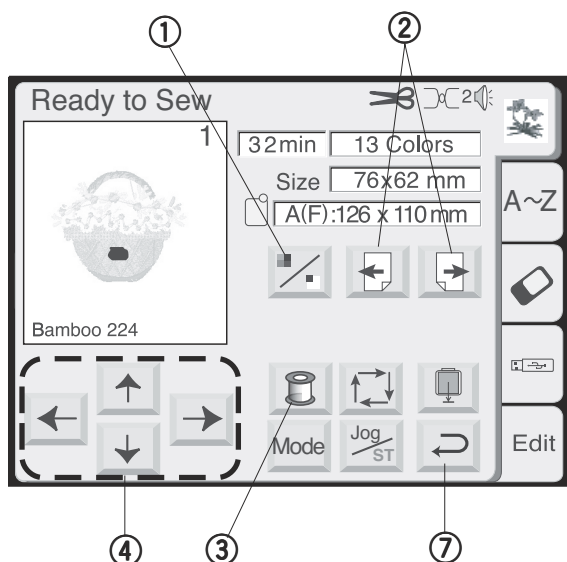

### ① Color section key

Press this key to show the complete image of the selected design or partial image of each color section.

### ② Next/Previous section keys

To view the next color section, press the **Next section** key. Press the **Previous section** key to view the previous color section.

### ③ Color list key

Press this key to display a list of thread colors employed in the selected design.

### Sewing the specific color (section) by skipping:

You can sew only the specific section of the design by skipping the sections before it.

Press the next section key until the desired section is displayed.

### ④ Jog Keys

Adjust the hoop position with the **Jog keys** so that the needle drop position comes right above the center of the centerlines on the fabric.

⑤ Needle drop position

⑥ Centerlines

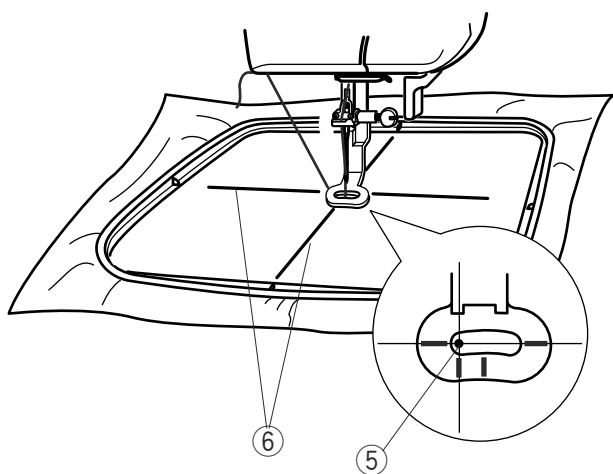

### ⑦ Return key

Press this key to return to the pattern selection window.

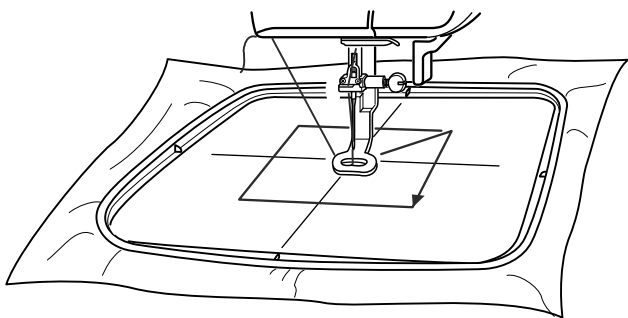
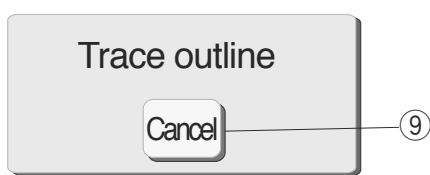
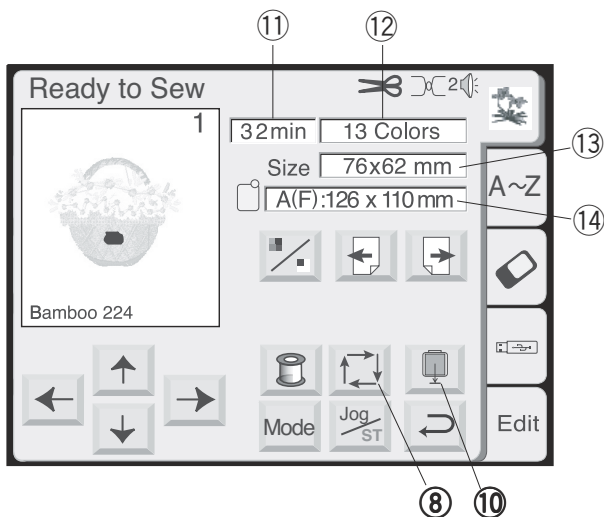

### ⑧ Trace key

You can check the size of the sewing area by pressing this key. The carriage traces the outline of the selected embroidery pattern without stitching.

The carriage will return to the starting position after tracing and the screen will return to the previous display.

To cancel the outline tracing, press the cancel key.

⑨ Cancel key

### ⑩ Carriage store key

Press the **Carriage store** key to bring the carriage back to its stored position after finishing embroidery.

### Screen Information

Besides the design image, approximate sewing time in minutes, number of colors, design size and the hoop that should be used for the selected design are shown.

⑪ Sewing time in minutes

⑫ Number of colors

⑬ Design size

⑭ Hoop

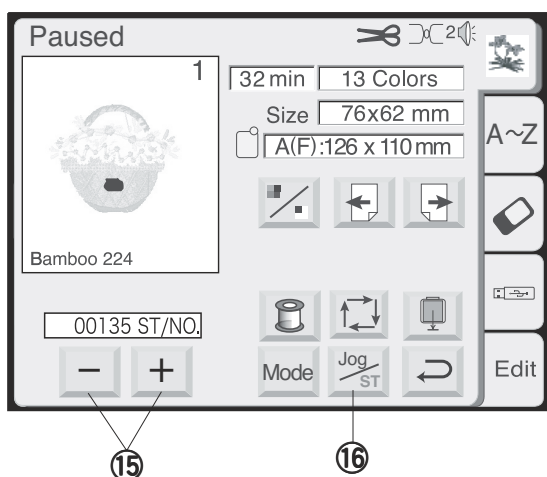

### ⑮ Stitch Back/Forward keys

When embroidery sewing has started, the screen will indicate the current stitch counts. The **Jog keys** will disappear and the **Stitch back/forward** keys will be indicated on the screen. You can use these keys to move the embroidery hoop to where the thread has broken or run out.

Press the **Minus** (-) key to move the hoop back to a previous sewing point. The hoop will move backward every 10 stitches when you press this key.

Press the **Plus** (+) key to move the hoop ahead. The hoop will move forward every 10 stitches when you press this key.

### ⑯ Jog/ST key

Press this key to switch the **Jog** keys to the **Stitch back/forward** keys before sewing.

### NOTE:

Before you turn the power switch **OFF**, always be sure to return the carriage to its stored position.

## EMBROIDERY SEWING

### Starting to Sew Embroidery



- 1 Select the desired pattern.

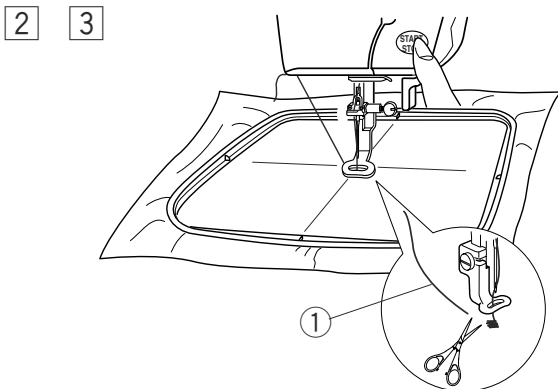

- 2 Lower the presser foot, press the **Start/Stop** button and sew 5 to 6 stitches. Press the **Start/Stop** button again to stop the machine.

- 3 Raise the presser foot, cut off the thread tail close to the beginning of the starting point and lower the presser foot.

① Thread tail

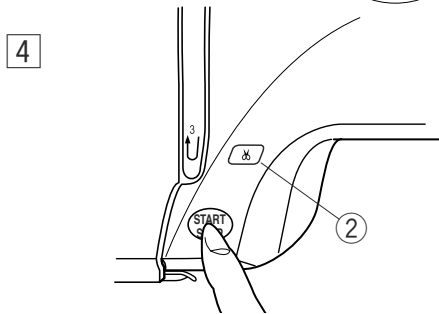

- 4 Press the **Start/Stop** button to start sewing again and the machine stops sewing automatically when the first color section is finished.

The machine will trim the threads automatically if you enabled the auto thread cutting command.

#### NOTE:

If you disabled auto thread cutting, press the **Auto thread cutter** button or trim the threads manually.



- 5 After finishing embroidery, press the auto thread cutter button to cut the threads.

Press the **Carriage store** key to return the carriage to the stored position.

② Auto thread cutter button

③ Carriage store key

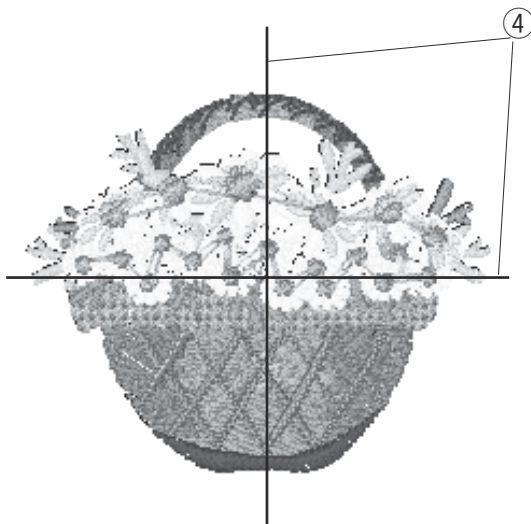

### Sewing results

The embroidery stitch pattern is sewn on the centerlines on the fabric as shown .

④ Centerlines on the fabric

#### NOTES:

The embroidery stitch pattern position against the centerlines is indicated on the template sheets. For embroidery sewing with the PC cards, use the included template sheets to set correct sewing position.

## MONOGRAMMING

### Monogram Selection Window

In the monogram selection window, you can program lettering by pressing the alphabet keys directly. After you press an alphabet key, the letter is memorized and the cursor is moved to the right side.

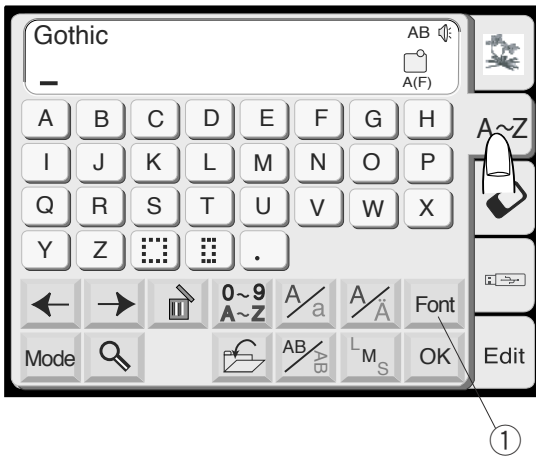

### Selecting the fonts

You can select one of 3 styles of font as well as 2-letters and 3-letters monogramming.

Press the **Font** key and the font selection window will open.

- ① Font key

Pressing one of the following keys to select the desired font.

- ② Gothic font
- ③ Script font
- ④ Cheltenham font
- ⑤ 2-Letters
- ⑥ 3-Letters

To cancel your selection, press the **Return** key.

- ⑦ Return key

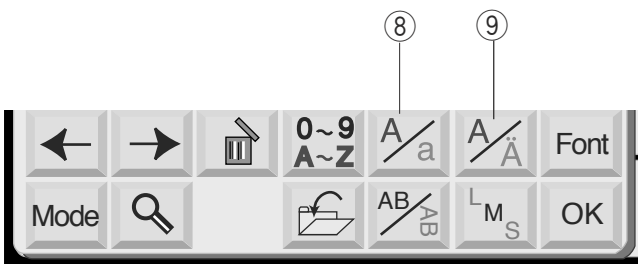
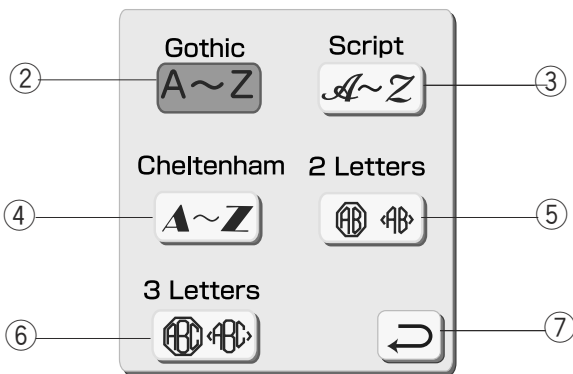

### Letter case

You can select upper or lower case letters by pressing the **Letter case** key.

- ⑧ Letter case key

### European letters

You can select the European letters, such as diaeresis, by pressing the **European letter** key.

- ⑨ European letter key

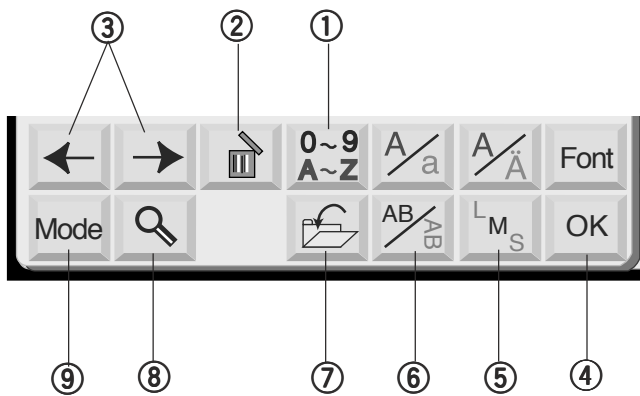

### ① Number/Symbol key

When you press this key, the number and symbols will appear. To select the number or symbol, press the correspondent key.

Press this key again to return to the letter selection window.

### ② Delete key

Characters can be deleted when they are underlined by the cursor. Move the cursor under the letter, number or symbol you want to delete and press the **Delete** key.

### ③ Cursor keys

Slide the cursor to the right or left by pressing either of the arrow keys. To add letters/numbers/symbols (character) into a monogram, move the cursor under a character. Press the new character key and it will be inserted on the left side of the underlined character.

### ④ OK key

The selected letter/number/symbol monogram combination is confirmed by pressing the **OK** key. After the key is pressed the screen will change to the **Ready to Sew** screen.

### ⑤ Letter Size key

You can choose 3 different sizes of letters: large, medium and small. Set the size of monogram before selecting the characters.

### ⑥ Horizontal/Vertical key

You can choose the direction of the monogramming either horizontal or vertical.

### ⑦ File Save key

You can save the programmed monogram by pressing this key. The **File Save** window will appear (refer to page 42).

### ⑧ Magnifier key

Pressing this key enlarges the Letter/Number keys to make entry easier.

Press the **Return** key to return to the original screen.

⑩ Enlarged keys

⑪ Return key

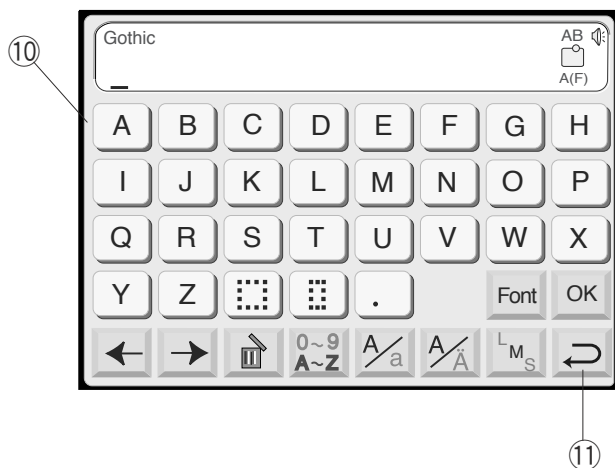

### ⑨ Mode key

Refer to page 20.



## Monogram Embroidery

**Example: “Bear” in Gothic style**

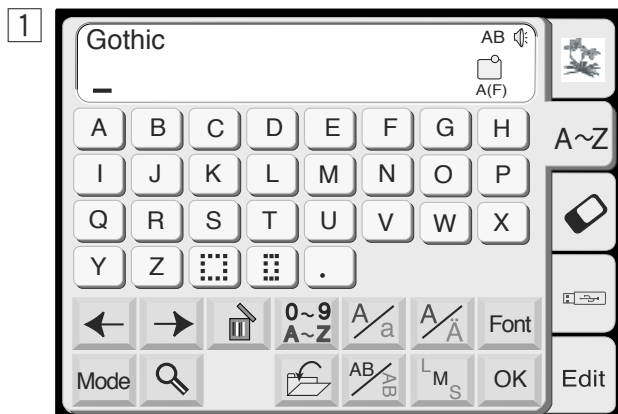

- 1 Press the font key and select the Gothic style letters. Select “**B**”.



- 2 Press the **Letter case**  $\frac{A}{a}$  key to select lower case letters.



- 3 Select “e”, “a” and “r”. Press the **OK** key.

**NOTE:**  
If you wish to change the orientation of monogramming, press the Horizontal/Vertical key before you press the OK key.



- 4 The display will change to the **Ready to Sew** screen.

### Multi-color monogramming

You can sew a multi-color monogram by changing the thread color of each letter if you press the **Color change** key before sewing.

The machine will stop automatically when each letter has been sewn. Change the thread and start sewing again.

- ① Color change key

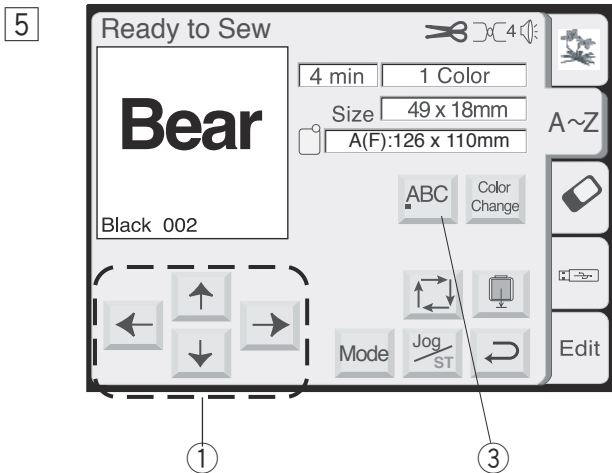

5 Use the **Jog** keys to adjust the position of the hoop to match the centerlines.

- ① Jog keys
- ② Centerlines

**NOTE:**

You can select one of the 3 placements of the monogramming, left justified, center justified or right justified, by pressing the **Justification** key.

- ③ Justification key

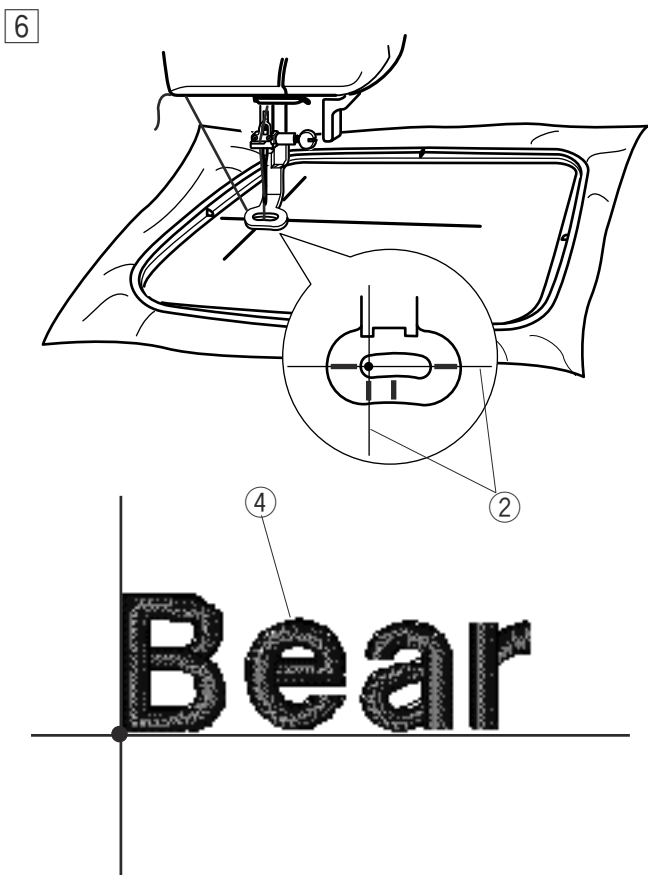

6 Lower the presser foot, press the **Start/Stop** button and sew 5 to 6 stitches.

Press the **Start/Stop** button again to stop the machine.

Raise the presser foot, cut off the thread tail close to the beginning of the starting point and lower the presser foot.

Press the **Start/Stop** button to start sewing again and the machine stops sewing automatically when the sewing is finished.

**Orientation of monogramming**

You can sew the monogramming in horizontal or vertical orientation.

Press the **Horizontal/Vertical** key before pressing the OK key to select the orientation.

- ④ Monogramming in horizontal orientation
- ⑤ Monogramming in vertical orientation

1

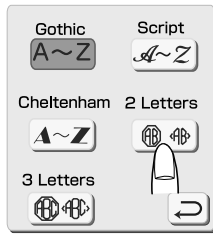
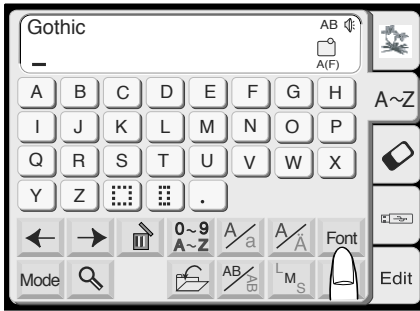

## 2- Letters Monogram

**Example:** 2-Letters with a crest

1 Press the **Font** key. Select 2-Letters.

2

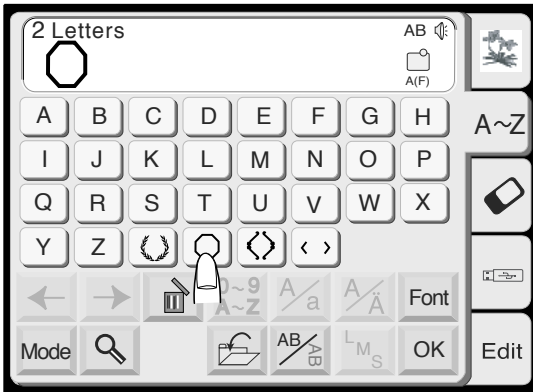

2 Select the crest.

3



3 Select letters "A" and "B". Press the **OK** key.

4 5

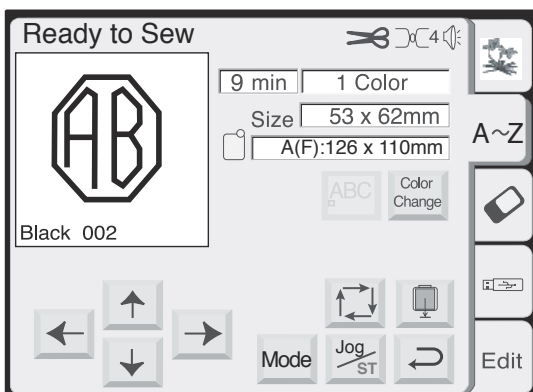

4 The screen will change to the **Ready to Sew** screen.

5 Press the **Start/Stop** button to start sewing.

### NOTES:

The 3-Letters monogram will be sewn in the same way as the 2-Letters monogram.  
 The starting position for the 2-Letters and 3-Letters is in the center of the hoop.

## Correcting the Monogram

### Deleting a letter

**Example:** To delete “E” from “BEAT”

- 1 Press the  key to shift the cursor under the letter to delete.

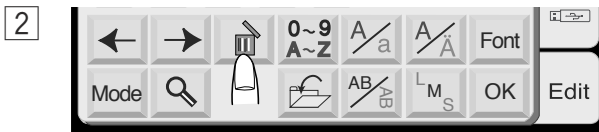

- 2 Press the **Delete**  key.



- 3 The letter “E” will be deleted.

### Inserting a letter

**Example:** To insert “O” to “BAT”

- 1 Press the  key to shift the cursor under the next letter where you wish to insert a letter.



- 2 Select the letter “O”.  
The letter “O” will be inserted between “B” and “A”.



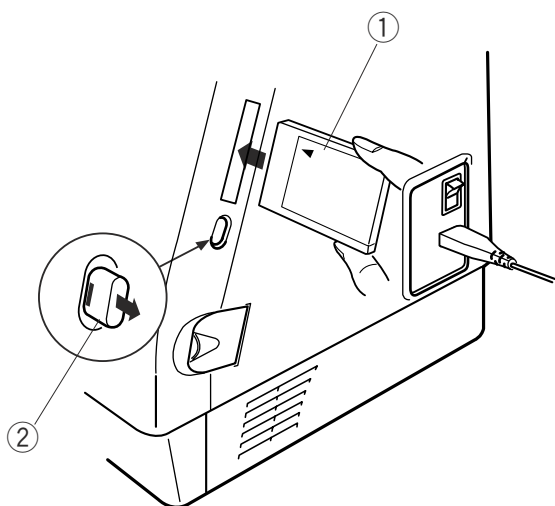

## OPTIONAL ITEMS

### PC Cards (optional item)

#### Inserting and ejecting a PC card

Insert the PC card into the slot with the front side facing toward you.  
Push the card in until it clicks, the eject button will pop out.

- ① PC card
- ② Eject button

#### NOTE:

When the card is properly set, the red bar on the eject button will show.

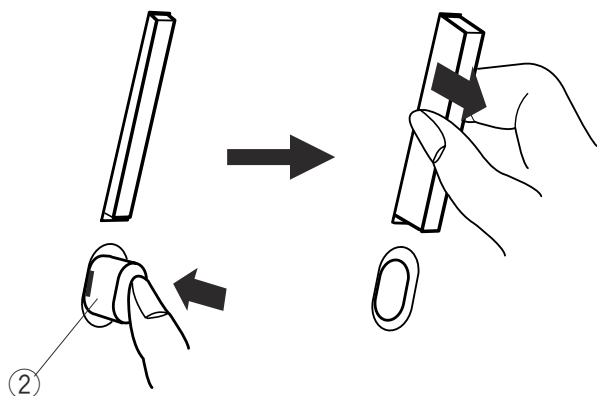

#### Ejecting the PC card

Press the Eject Button to eject the PC card.  
Take out the PC card from the machine.

#### NOTE:

When the power is turned on with a PC card inserted in the machine, it will take a few moments to get the machine booted up.



#### Selecting the PC card designs

Press the **PC card** tab. The designs contained in the card are displayed on the pattern selection keys.

Press the **Pattern selection** key to select the design you wish to sew.  
The **Ready to Sew** screen will appear.

#### CAUTION:

Do not turn the power off or eject the card while the warning sign or hourglass is displayed.

## USB Memory (optional item)

The USB memories can be used to save stitch data and transfer the embroidery designs between the MC 350E and your PC.

The USB memory is available at camera shops, PC supplies stores etc. in various sizes and forms.

Open the small door under the card slot.

Insert the USB memory into the USB socket on the MC350E.

- ① Small door
- ② USB memory (optional item)
- ③ USB socket

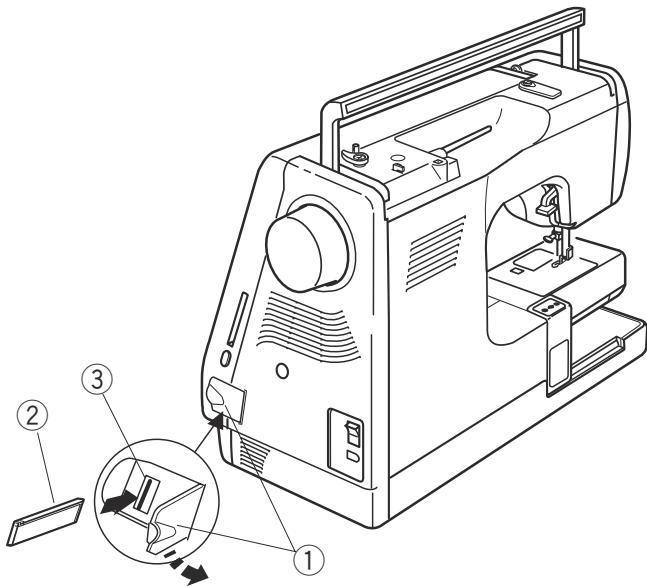

### CAUTION:

Do not turn the power off or disconnect the USB memory while the warning sign    or hourglass is displayed.

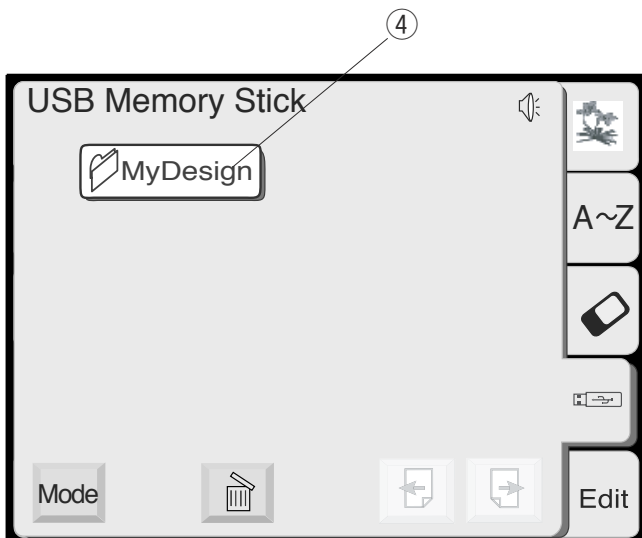

## Opening the designs on USB memory

Press the **USB memory** tab.

The folder list is displayed in the window.

Press the desired **Folder selection** key to select it.

- ④ Folder selection key

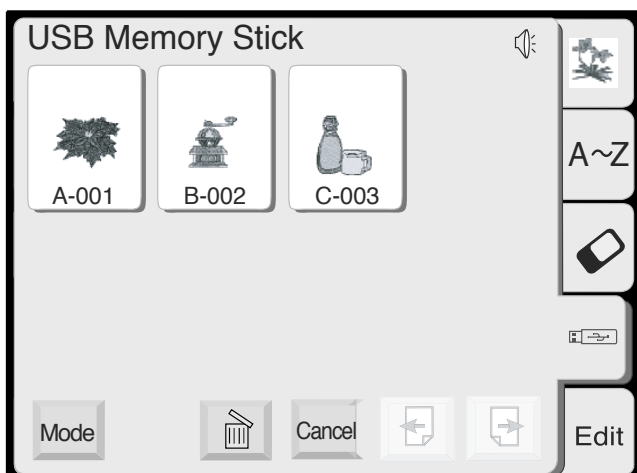

The designs contained in the selected folder will be displayed on the **Pattern selection** keys.

Press the **Pattern selection** key to select the desired pattern.

## EDITING MODE

The editing function allows you to modify and combine embroidery patterns to create your own original designs.

### Editing Screen

Press the **Edit** tab to open the Editing window.

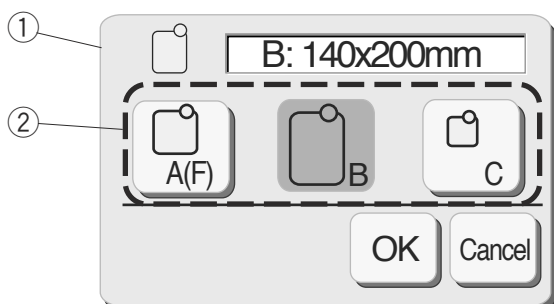
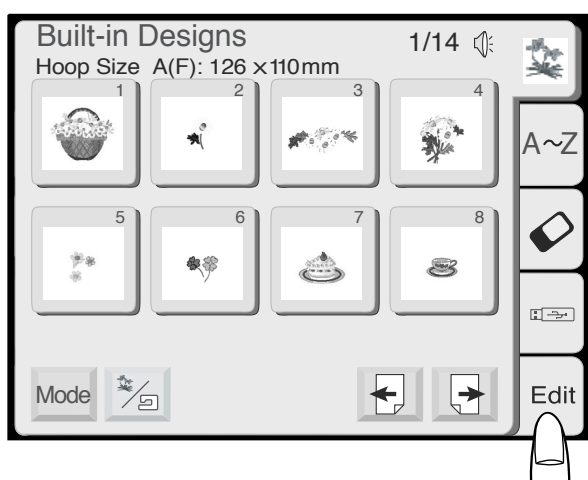

The **Hoop selection** dialog box opens to allow you to select the hoop you wish to use.

You can select one of the following hoops:

Standard Hoop A: 126 mm by 110 mm

Round Hoop F: 126 mm by 110 mm (Optional item)

Large Hoop B: 140 mm by 200 mm

Free arm Hoop C: 50 mm by 50 mm (Optional item)

- ① Hoop selection dialog box
- ② Hoop selection key

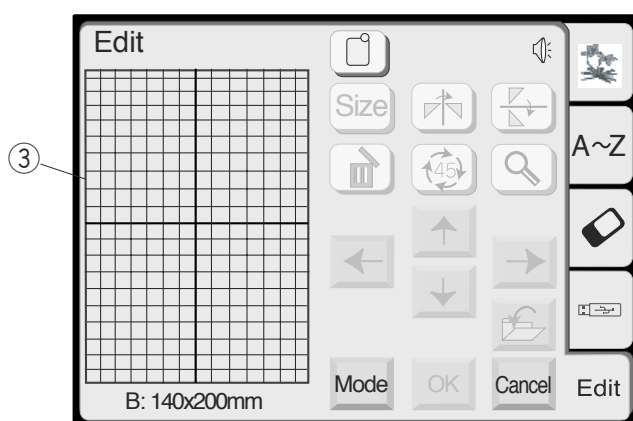

Press the **OK** OK key and the Editing window for the selected hoop will open.

Press the **Cancel** Cancel key to cancel the selection and return to the Editing window for the hoop B.

Refer to page 39 for hoop selection after selecting the embroidery pattern.

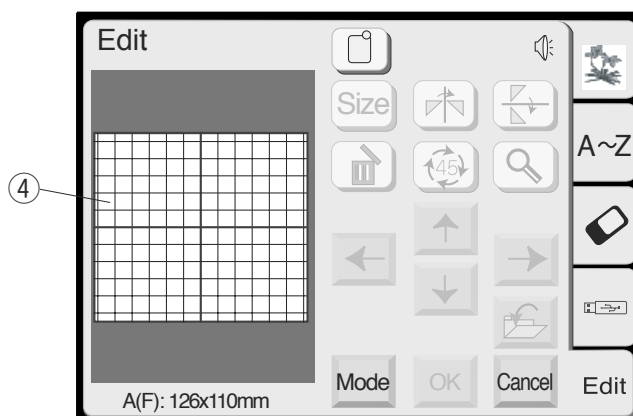

- ③ Editing window for the hoop B
- ④ Editing window for the hoop A

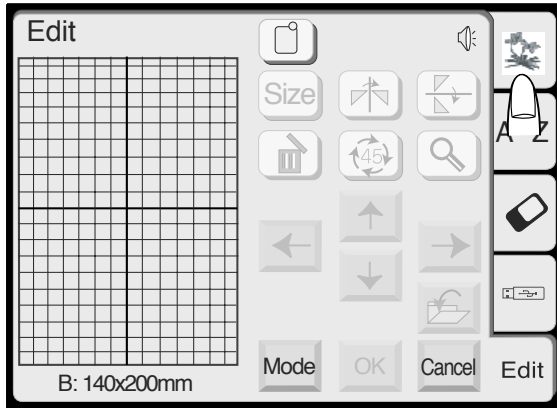

### Importing the designs in the Editing window.

Press the **Built-in design**, **PC card** or **USB memory** tab in the editing window.

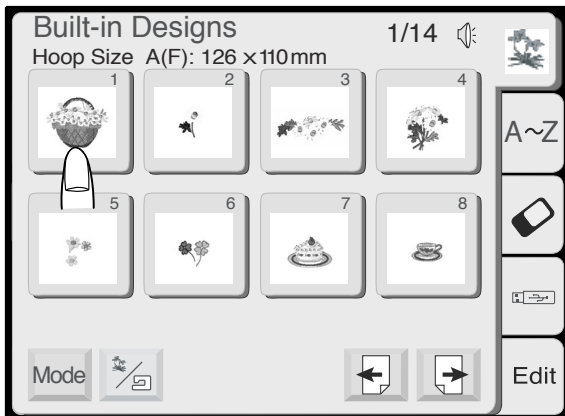

Press the desired **Pattern selection** key or enter characters for monogramming.

The selected pattern will be displayed in the **Editing** window.

### Editing the Embroidery Designs

To select the pattern to edit, press the image of the desired pattern on the Editing window. The pattern will be framed when it is selected.

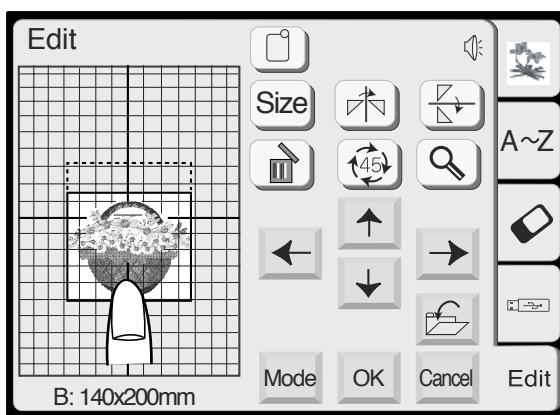

### Moving the selected pattern

To move the embroidery pattern on the Editing window, press and drag the pattern to a desired location with your fingertip.

**CAUTION:**  
Do not drag the pattern on the screen with a sharp pointed object.



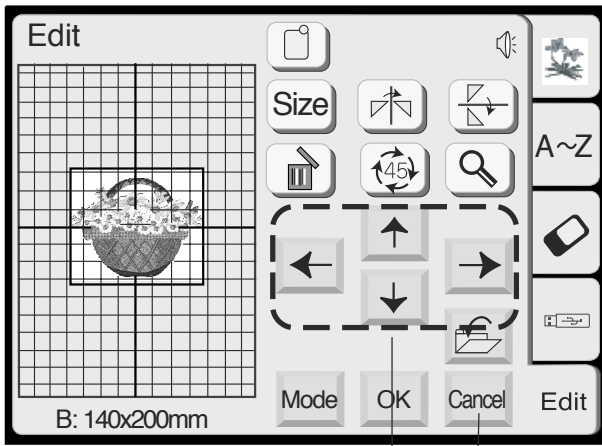

①

### Moving the selected pattern (continued)

You can move the selected pattern also by pressing the **Layout** keys

Press the **Layout** keys to move the pattern to the desired position in the **Editing** window.

The carriage will not move when you are pressing the layout keys since pattern position will move relatively to the hoop, not to the machine.

① Layout keys

### NOTES:

The appearance of the **Layout** keys is the same as the **Jog** keys but their function is different. Use the **Jog** keys to move the carriage.

To cancel any changes that have been made, press the Cancel key.

② Cancel key

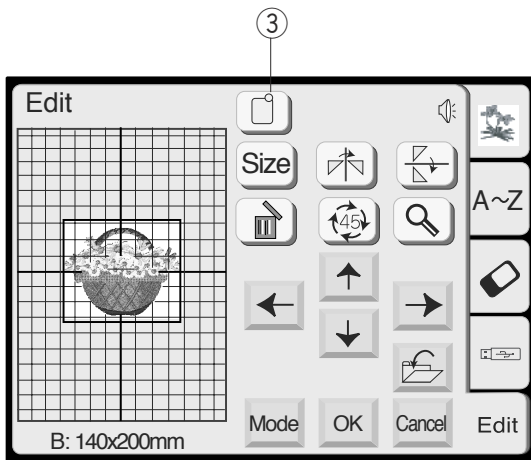

### Changing the hoop size

You can change the hoop size by pressing the **Hoop selection** key.

③ Hoop selection key

Select one of the following hoops:

Standard Hoop A: 126 mm by 110 mm

Round Hoop F: 126 mm by 110 mm (Optional item)

Large Hoop B: 140 mm by 200 mm

Free arm Hoop C: 50 mm by 50 mm (Optional item)

Press the **OK**  key and the **Editing** window for the selected hoop will appear.

④ OK key



④

⑤

Press the **Cancel**  key to return to the default setting (Hoop B).

⑤ Cancel key

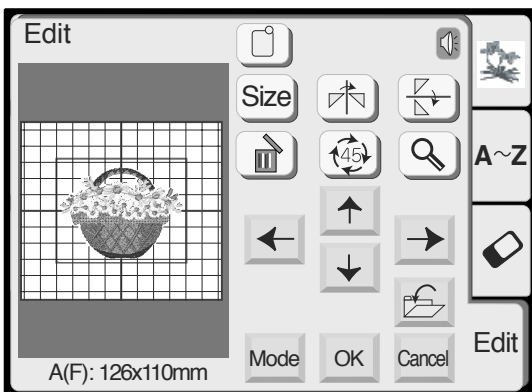

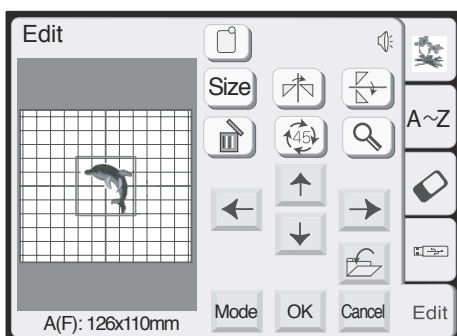
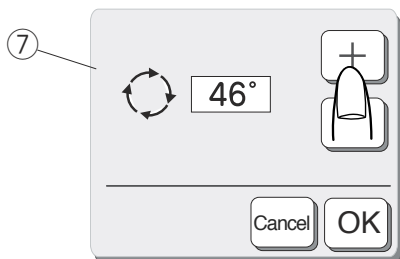
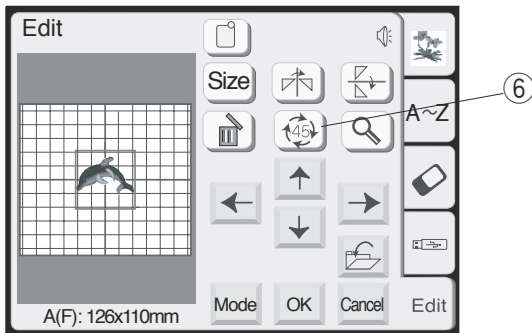
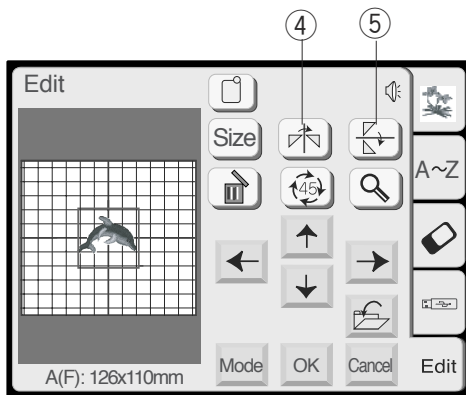
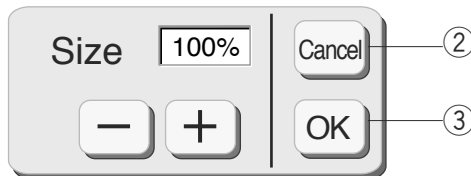
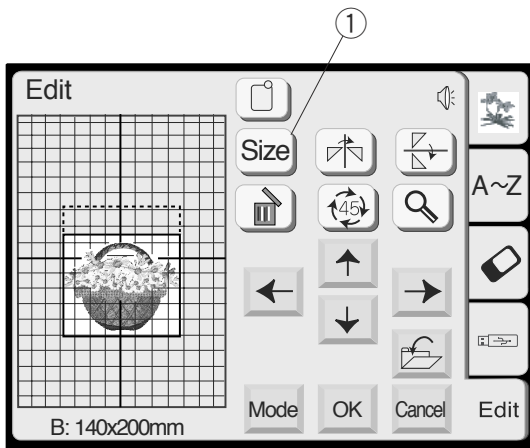

### Resizing the selected pattern

When you press the **Size** key, the size adjusting dialog box will open.

You can change the size of the embroidery patterns from 90% to 120% of the original pattern size.

- ① Size key

The size will change 1% each time you press the plus or minus keys.

Press the **Plus**  $+$  key to enlarge the pattern size. Press the **Minus**  $-$  key to reduce the pattern size.

To cancel size change, press the **Cancel**  $\text{Cancel}$  key. Press the **OK**  $\text{OK}$  key to apply the new size.

- ② Cancel key
- ③ OK key

### Flipping the pattern

When you press the **Mirror Image** keys, you may embroider a mirror image of the pattern.

Press the **Vertical mirror**  $\text{Vertical mirror}$  key to flip patterns from left to right.

Press the **Horizontal mirror**  $\text{Horizontal mirror}$  key to flip from top to bottom.

- ④ Vertical mirror key
- ⑤ Horizontal mirror key

### Rotating the selected pattern

Each time you press the **Rotation** key, the embroidery pattern will rotate 45 degrees clockwise.

- ⑥ Rotation key

When you press and hold the **Rotation** key one second or longer, the **Rotation** dialog box will open.

- ⑦ Rotation dialog box

Press the **Plus**  $+$  key to rotate the pattern every one degree clockwise.

Press the **Minus**  $-$  key to rotate the pattern every one degree counterclockwise.

Pressing and holding the **Plus** or **Minus** key will rotate the pattern quickly.

Press the **OK** key to apply the new angle. To cancel rotation, press the **Cancel** key

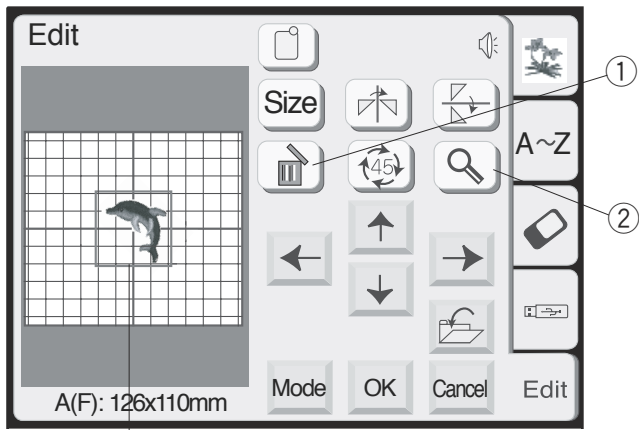

### Deleting the pattern

When you press the **Delete** key, the selected pattern will be deleted.

- ① Delete key

④

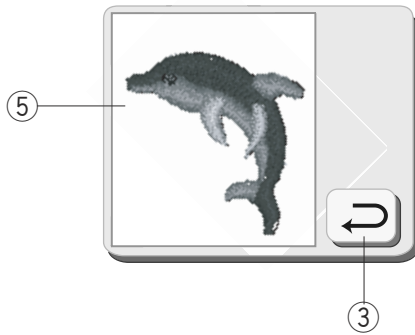

### Magnifying the pattern image

Press the **Magnifier** key to show a magnified image of the selected pattern.

Press the **Return**  key to return to the previous screen.

- ② Magnifier key
- ③ Return key
- ④ Original image
- ⑤ Magnified image

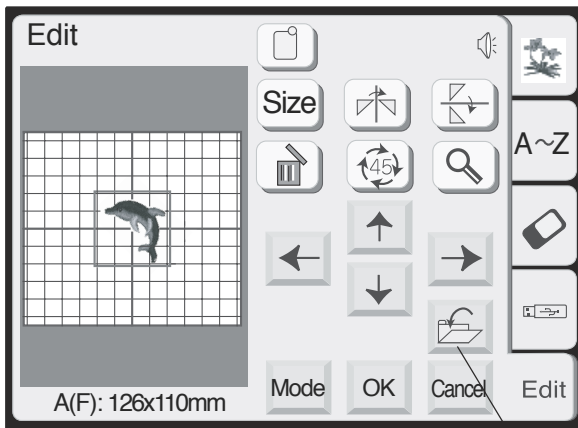

## SAVING A FILE

When you press the **Save file** key, the **Save file** dialog box will open.

- ① Save file key

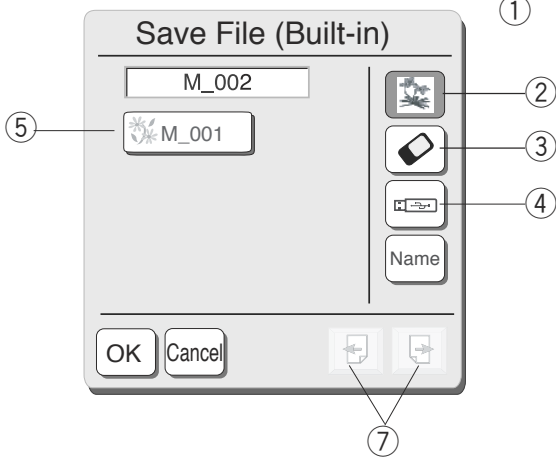

You can select a memory location from Built-in memory, ATA PC card or USB memory.

Press one of the following keys to select the desired location to where you wish to save the file.

- ② Built-in memory key
- ③ ATA PC card key
- ④ USB memory key

The **File list** will open if you press the Built-in memory key, while the **Folder list** will open if you press the PC card key or USB memory key.

- ⑤ File list
- ⑥ Folder list

When you press the **Page** keys, you will be able to see the saved files in the previous and next pages.

- ⑦ Page keys

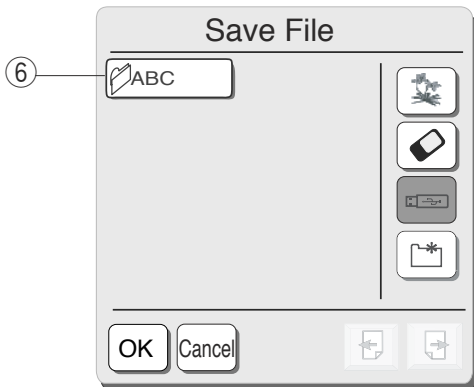

Select the desired folder and the file list of the selected folder will open.

Press the **OK** key to save the file and the screen will return to the original screen.

If you do not want to save the file, press the **Cancel** key to return to the previous window.

- ⑧ OK key
- ⑨ Cancel key

### NOTE:

The file name will be automatically assigned starting from M\_001 in order.

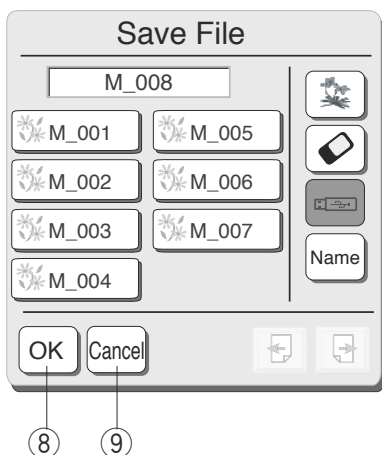

### CAUTION:

Do not turn the power off or eject the card when the warning sign or hourglass is showing on the visual touch screen. Otherwise, the data stored in the memory may be lost or damaged.

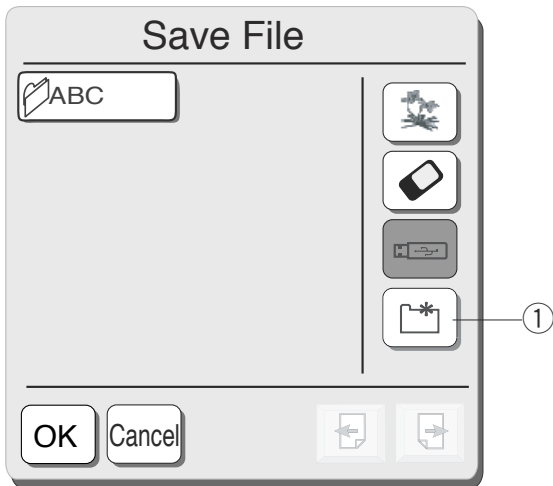

### Creating a new folder

You can create your own folder and assign the desired name to it.

Press the **New folder** key and the keyboard window will open.

① New folder key

Enter the folder name and press the **OK** OK key. The new folder will be added to the folder list.

② OK key

To go back to the folder list without creating a file, press the **Cancel** Cancel key.

③ Cancel key



### NOTES:

Only 8 characters can be entered.

To delete the last character, press the **Backspace** key.

④ Back space key

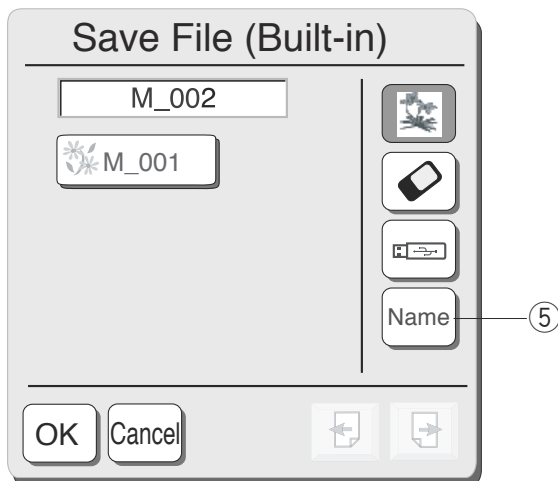

### Assigning the file name

Press the **File name** key if you wish to assign a new name to the file.

⑤ File name key

The keyboard window will open.

Enter the file name and press the **OK** OK key. The file will be saved with the new name.

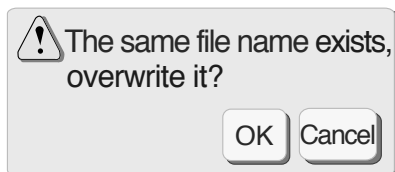

If you attempted to save the file using an existing name, the warning message will appear.

Press the **OK** OK key to overwrite the existing file.

Press the **Cancel** Cancel key if you do not wish to overwrite it. You may need to change the file name and save the file under the different name.

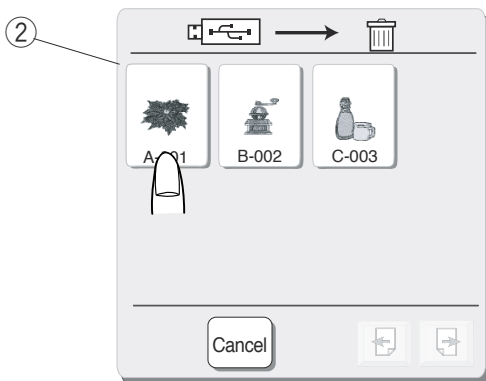
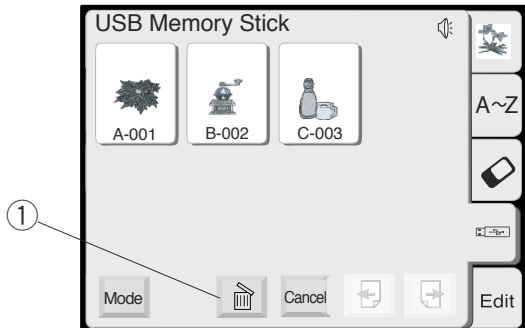
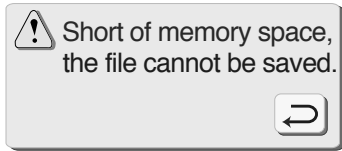

## Deleting the file

When the memory is full, a warning message will appear. Press the **OK** key and go to the open file window then delete the file that you do not need.

Press the **Built-in design**, **PC card** or **USB memory** tab to select the location of the file to delete.

Press the **Delete** key and the **File delete** dialog box will open.

- ① Delete key
- ② File delete dialog box

Press the **Pattern selection** key to select the file you wish to delete.

If you do not wish to delete the file, press the **Cancel** key.

The **Confirmation** dialog box will open. Press the **OK** key to delete the file.

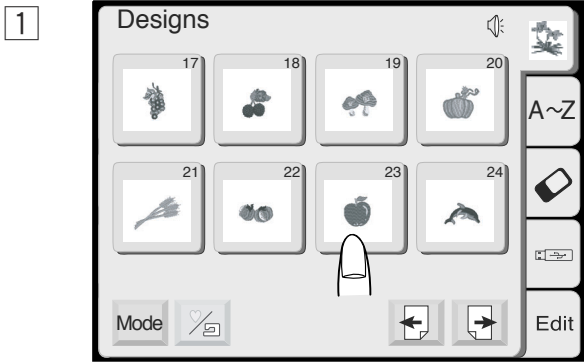

## CREATING AN ORIGINAL DESIGN

**Example:** To combine the built-in design #23 and a word "Apple"

1 Select design #23 from the built-in designs.

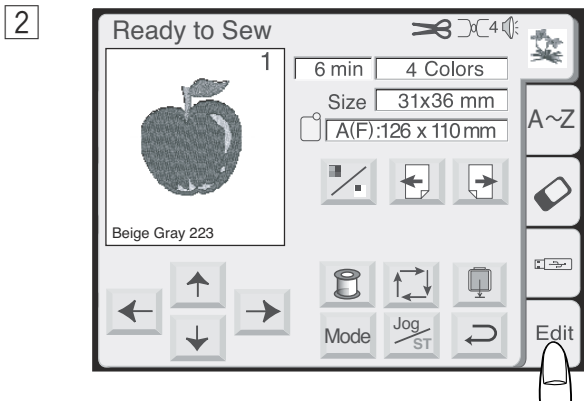

2 Press the **Edit** tab.  
The screen changes to the Editing window with the selected pattern image.

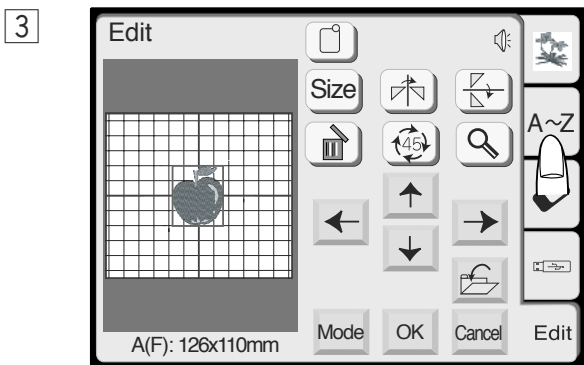

3 Press the **Monogram** tab.

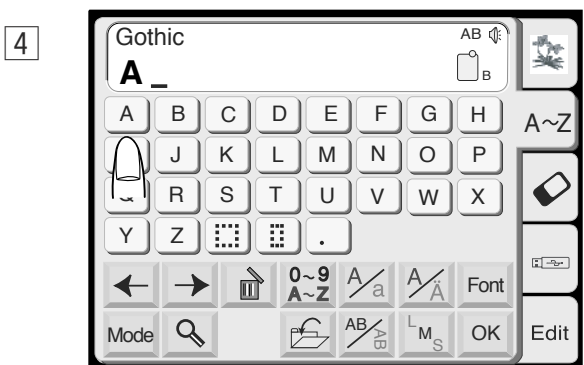

4 Select "A" (Upper case letter in Gothic style).



5 Press the **Letter case**  key to select lower case letters.



- 6 Select “p”, “p”, “l” and “e”.  
Press the **OK** key.

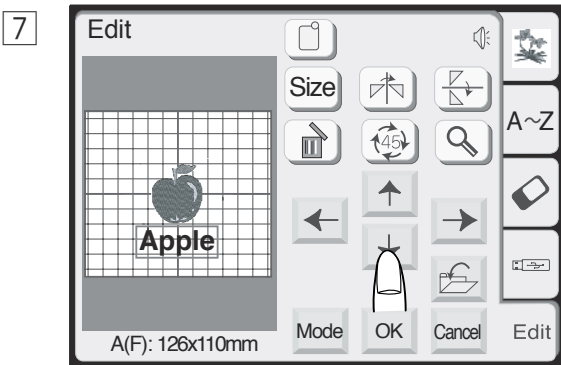

- 7 Lay the patterns out by dragging or using the **Layout** keys.

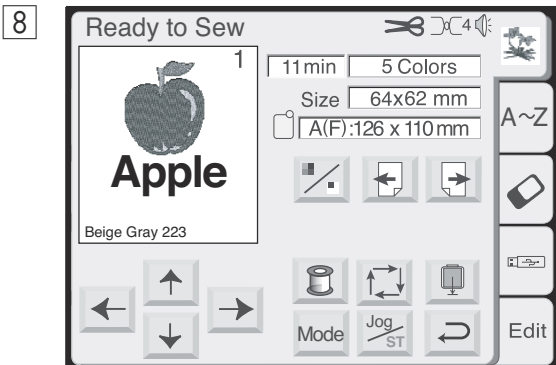

- 8 Press the **OK** key and the display will change to the **Ready to Sew** screen. Start the machine to sew.  
① Sewing result

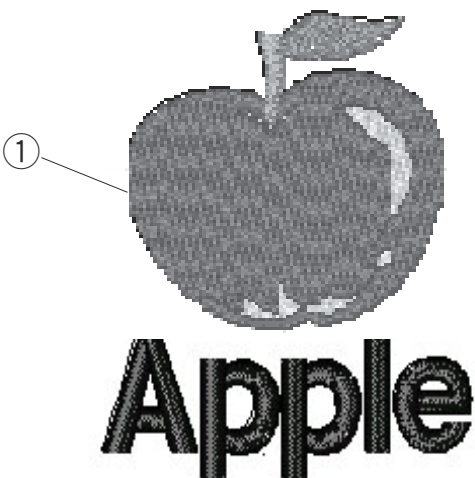



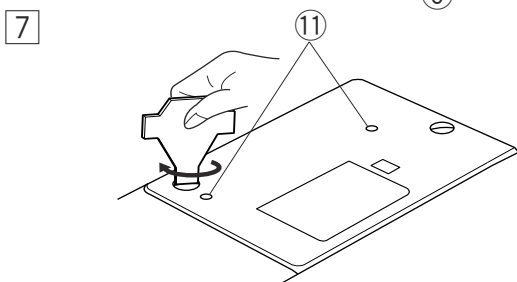
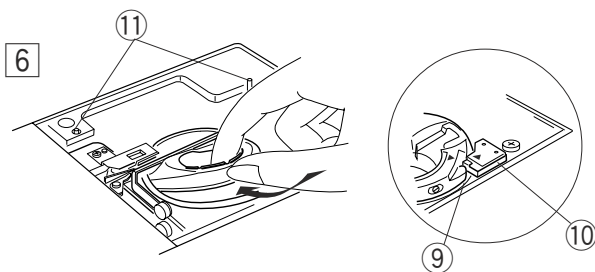
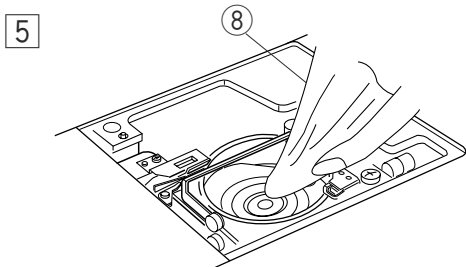
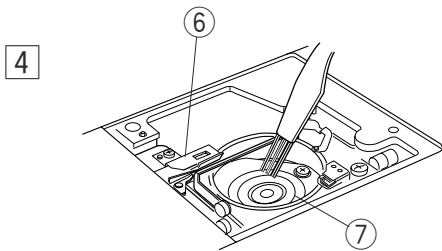
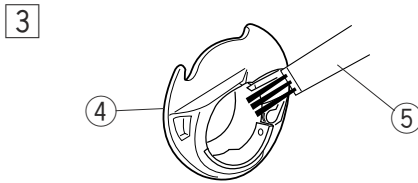
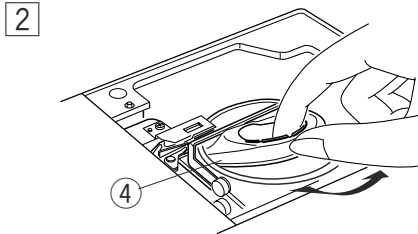
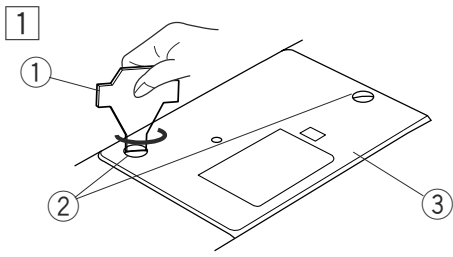

## CARE AND MAINTENANCE

### Cleaning the Hook Race



#### WARNING:

Turn the power switch off and unplug the machine before cleaning.

#### NOTE:

Do not dismantle the machine in any way other than what is explained in this section.

Clean the outside of the machine with a soft cloth and mild soap.

- 1 Remove the setscrews with the screwdriver supplied with the machine. Remove the needle plate.
- 2 Lift up the bobbin holder and remove it.
  - 1 Screwdriver
  - 2 Setscrews
  - 3 Needle plate
- 3 Clean the bobbin holder with a lint brush.
  - 4 Bobbin holder
  - 5 Lint brush
- 4 Clean the Auto thread cutter mechanism and hook race with the lint brush.
  - 6 Auto thread cutter mechanism
  - 7 Hook race
- 5 Clean the hook race with a dry cloth. (You may also use a vacuum cleaner.)
  - 8 Dry cloth

### Assemble the hook race

- 6 Insert the bobbin holder so that the knob fits next to the stopper in the hook race.
  - 9 Knob
  - 10 Stopper
- 7 Reattach the needle plate, aligning the needle plate guide pins with the guide holes on the needle plate and tighten the screw.
  - 11 Needle plate guide pins

#### NOTE:

After cleaning the machine, make sure the needle and presser foot are attached.

## Replacing the Light Bulb



### WARNINGS:

Turn off the power before replacing the light bulb.  
The bulb could be **HOT**, wait until it has cooled down before touching it.

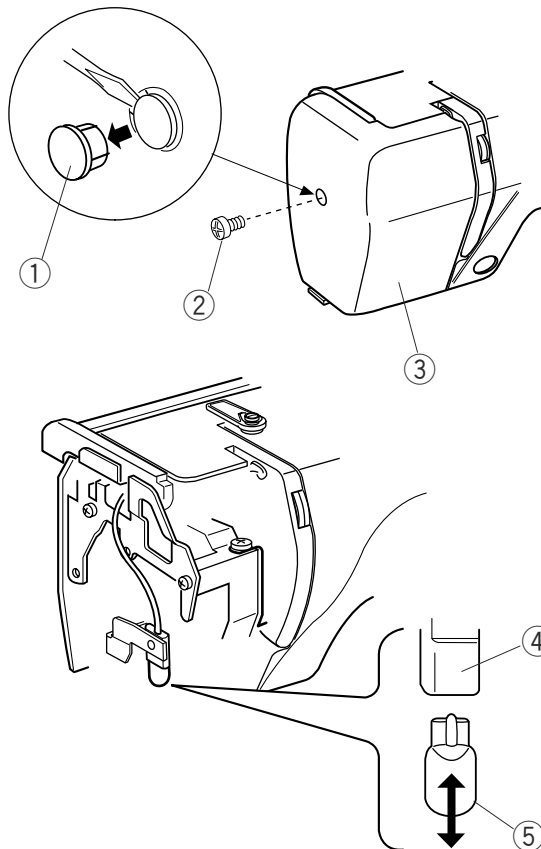

### To remove:

Remove the cap and setscrew. Remove the faceplate.  
Pull out the bulb from the socket.

### To replace:

Insert a new bulb into the opening of the socket.  
Attach the faceplate with the setscrew, and attach the cap.

- ① Cap
- ② Setscrew
- ③ Faceplate
- ④ Lamp Socket
- ⑤ Light bulb

### NOTE:

Do not store the machine in a high humidity area, near a heat radiator or in direct sunlight.  
Store the power supply cable in the extension table.

## Troubleshooting

Problem:	Cause:	Reference:
The machine is noisy	1 Threads have been caught in the hook mechanism.	See page 47.
The needle thread breaks.	1 The needle thread is not threaded properly. 2 The needle thread tension is too tight. 3 The needle is bent or blunt. 4 The needle is inserted incorrectly. 5 The needle thread is not set in the thread holder when starting the machine.	See pages 9, 10. See page 13. See page 14. See page 14. See page 12.
The bobbin thread breaks.	1 The bobbin thread is not threaded properly in the bobbin holder. 2 Lint has collected in the bobbin holder. 3 The bobbin is damaged and does not turn smoothly.	See page 8.  See page 47. Replace the bobbin.
The needle breaks.	1 The needle is inserted incorrectly 2 The needle is bent or blunt. 3 The needle clamp screw is loose. 4 The needle thread tension is too tight.	See page 14 See page 14. See page 14. See page 13.
Visual Touch Screen is not clear.	1 The screen contrast of the visual touch screen is not adjusted correctly.	See page 21.
Skipped stitches.	1 The needle is inserted incorrectly. 2 The needle is bent or blunt. 3 The needle thread is not threaded properly. 4 The defective needle (rusted, burred needle eye) is used. 5 The embroidery hoop is not set properly. 6 The fabric is not tightly pulled on the embroidery hoop. 7 A stabilizer is not being used.	See page 14. See page 14. See pages 9, 10 Replace the needle. See page 18. See page 17. See page 16.
The machine does not run.	1 A thread is caught in the hook race. 2 The control circuit is not working correctly.  3 The machine is not connected to the power supply.	See page 47. Turn the switch off and turn it on again. See page 5.
Abnormal noise occurs when the machine is switched on.	1 Something is caught between the carriage and the arm. 2 The carriage is touching something around the machine.	Remove the object. See page 18.
Patterns are distorted.	1 The fabric is not pulled tightly on the embroidery hoop. 2 The embroider hoop is not fixed securely. 3 The carriage is bumping into something around the machine. 4 The fabric is caught or pulled for some reason when sewing embroidery. 5 The needle thread tension is too tight. 6 A stabilizer is not used.	See page 17. See page 18. See page 18.  Stop the machine and free the fabric. See page 13. See page 16.
Pattern selection keys do not work.	1 Key position is not adjusted properly. 2 The control circuit is not working correctly.  3 The bobbin winder spindle is in the winding position.	See page 22. Turn the switch off and turn it on again. See page 7.
PC card or USB memory does not work	1 The card or USB memory is not inserted correctly	See pages 35, 36.

**JANOME**