



b44  
FUNLOCK



Instruction Manual

bernette

SWISS DESIGN



# TABLE OF CONTENTS

<b>NAME OF PARTS</b>	<b>7</b>	Threading the Lower Looper (Red)	<b>21</b>
Details of machine	7	Threading the Overlock Right Needle (Green)	23
<b>ACCESSORIES</b>	<b>9</b>	Threading the Overlock Left Needle (Yellow)	24
Standard	9	<b>HOW TO CHANGE THREADS</b>	<b>26</b>
Needle Information	9	Tie on method	26
<b>HOW TO OPEN LOOPER COVER</b>	<b>10</b>	<b>HOW TO ADJUST</b>	<b>27</b>
Principal Parts behind the Looper Cover	10	Stitch length dial	27
<b>PREPARATION TO SEWING</b>	<b>10</b>	Seam Width	27
Power Switch	10	The presser foot pressure	28
Foot Controller	10	<b>DIFFERENTIAL FEED</b>	<b>29</b>
Cut-offs Bin	11	Gathered Overlock (1–2.0)	29
<b>PREPARATION FOR THREADING</b>	<b>12</b>	Stretch Overlock (1–0.6)	30
Setting up the Retractable thread stand	12	<b>CHAINING OFF AND TEST SEWING</b>	<b>31</b>
Spool net	12	<b>HOW TO SEW AN OVERLOCK STITCH</b>	<b>32</b>
Spool Cap	12	2–Thread Wrapped Overlock (9/10)	32
<b>HOW TO DISENGAGE UPPER KNIFE</b>	<b>13</b>	2–Thread Overlock (14/15)	33
<b>UPPER LOOPER CONVERTER (ULC)</b>	<b>14</b>	3–Thread Overlock (3/4)	34
Use the upper looper converter	14	3–Thread Flatlock (5/6)	35
Disengage To Upper Looper	14	2–Thread Flatlock (11/12)	36
<b>STANDARD OVERLOCK AND ROLLED HEM STITCHING</b>	<b>14</b>	3–Thread Super Stretch (2)	37
Sew Standard Overlock	14	4–Thread Overlock with integrated safety seam (1)	38
Sew Rolled Hem	15	<b>HOW TO SEW A ROLLED HEM</b>	<b>39</b>
<b>HOW TO REMOVE AND INSERT NEEDLES</b>	<b>15</b>	Machine set up	39
Needle Position	15	Additional information about rolled hemming	40
To Remove Needle(s)	16	3–Thread Narrow Seam (7)	41
To Insert Needle(s)	16	3–Thread Rolled Hem (8)	41
<b>SELECTION OF STITCHES</b>	<b>17</b>	2–Thread Rolled Hem (13)	42
<b>THREADING THE MACHINE</b>	<b>19</b>	<b>STITCH VARIATIONS AND SEWING TECHNIQUES</b>	<b>43</b>
Threading Diagram	19	How To Sew a Flatlock Decorative Seam	43
Tension Color Code	19	Machine Set Up	43
Threading the Upper Looper (Blue)	20	Flatlocking a Seam	43

Decorative Flatlocking	44
Additional Information about Flatlocking	44
How to sew an Overlock Blind Hem	45
How to sew Pin Tucks	45
How to turning Square Corners	46
<b>MACHINE MAINTENANCE</b>	<b>48</b>
Cleaning The Machine	48
Oiling The Machine	48
Replace the Upper Knife	49
<b>OPTIONAL ACCESSORIES</b>	<b>50</b>
Snap-On Type Presser Foot	50
Optional Presser Foot	51
<b>TROUBLESHOOTING</b>	<b>52</b>
<b>FABRIC, THREAD AND NEEDLE CHART</b>	<b>53</b>
<b>SPECIFICATION</b>	<b>54</b>
Technical Summary	54

## IMPORTANT

Precautions should always be followed, including the following:

Read all the instructions before using this machine.

**In general when the machine is not in use, it should be disconnected from the electricity supply.**

## DANGER!

As a protection against electrical shock:

1. The machine should never be left unattended when plugged in.
2. Always unplug this machine from the electrical outlet after using and before cleaning.
3. LED Radiation. Do not view directly with optical instruments. Class 1M LED product.

## WARNING!

As a protection against burns, fire, electric shock or injury to persons:

1. Use this machine only for purposes as described in this manual. Use only attachments, accessories and parts recommended by the manufacturer.
2. Do not allow this machine to be used as a toy. Close attention is necessary when this machine is used by or near children. The machine is not intended for use by persons (and children) with reduced physical, sensory or mental capabilities or lack of experience and knowledge. Unless they have been given supervision or instruction concerning use of the machine by a person responsible for their safety. To ensure children do not play with



the machine they must be supervised.

Never operate this machine if:

- the cord or the plug are damaged,
  - it is not working properly,
  - it has been dropped or damaged,
  - it has fallen into water.
3. Return the machine to your local authorized BERNINA dealer for examination or repair.
  4. Never operate the machine with any air openings blocked. Keep ventilation openings of the machine free from the accumulation of lint, dust and loose cloth.
  5. Keep fingers away from all moving parts. Special care is required around the sewing needle and the knife.
  6. Never insert any objects into any openings on the machine.
  7. Do not use the machine outdoors.
  8. Do not operate the machine where aerosol products (sprays) or oxygen are being used.
  9. Do not pull or push the fabric while stitching. This can result in needle breakage.
  10. Switch the machine off «0» when making any adjustments in the needle area, such as threading the needle, changing the needle, threading the looper, or changing the presser foot.
  11. Always unplug the machine from the electrical outlet when removing covers, when covers are opened to raise the knife or thread the loopers, when lubricating or when making any other user servicing adjustments mentioned in the instruction manual.
  12. Do not use bent needles.
  13. Always use the original BERNINA stitch plate. The wrong stitch plate can cause needle breakage.
  14. This machine is provided with double insulation (except for USA and Canada). Use only original spare parts. See instructions for servicing of double-insulated products.
  15. Use only foot controller provided with this machine. (Type 4C-316B for USA & CANADA only).

## All rights reserved

For technical and product improvement reasons, the machine's features, parts and accessory are subject to unannounced changes and alterations at any time. The accessory included can differ from country to country.



### WARNING:

This machine is intended for household use only. If used intensively or commercially, regular cleaning and especially attentive care is required.

Signs of wear and tear owing to intensive or commercial use are not covered automatically, even if they occur within the warranty period. The decision on how to deal with any such cases rests with the local authorised servicing staff.

### PLEASE NOTE:

If the machine is stored in a cold room, it should be brought to a warm room about one hour before use.

## SERVICING OF DOUBLE-INSULATED PRODUCTS

In a double-insulated product two systems of insulation are provided instead of grounding. No grounding means is provided on a double-insulated product, nor should a means for grounding be added to the product. Servicing a double-insulated product requires extreme care and knowledge of the system and should be done only by qualified service personnel. Replacement parts for a double-insulated product must be identical to the original parts in the product. A double-insulated product is marked with the words: «Double insulation» or «Double insulated».

The symbol  may also mark such a product.

## SAVE THESE INSTRUCTIONS!

Europe only: This appliance may only be used by children over eight and by persons with reduced physical, sensory or mental capabilities or by persons who lack experience and knowledge of how to operate the machine under supervision, after instruction on how to use the equipment safely and once they have understood the potential dangers. Children shall not play with the appliance. Cleaning and user maintenance shall not be made by children without supervision.

Outside of Europe (except for the USA and Canada): This appliance may only be used by persons (including children) with reduced physical, sensory or mental capabilities or by persons who lack experience and knowledge of how to operate the machine under supervision and after instruction on how to use the equipment safely by a person responsible for their safety. Children should be supervised to ensure that they do not play with the appliance.

# NAME OF PARTS

## Details of machine

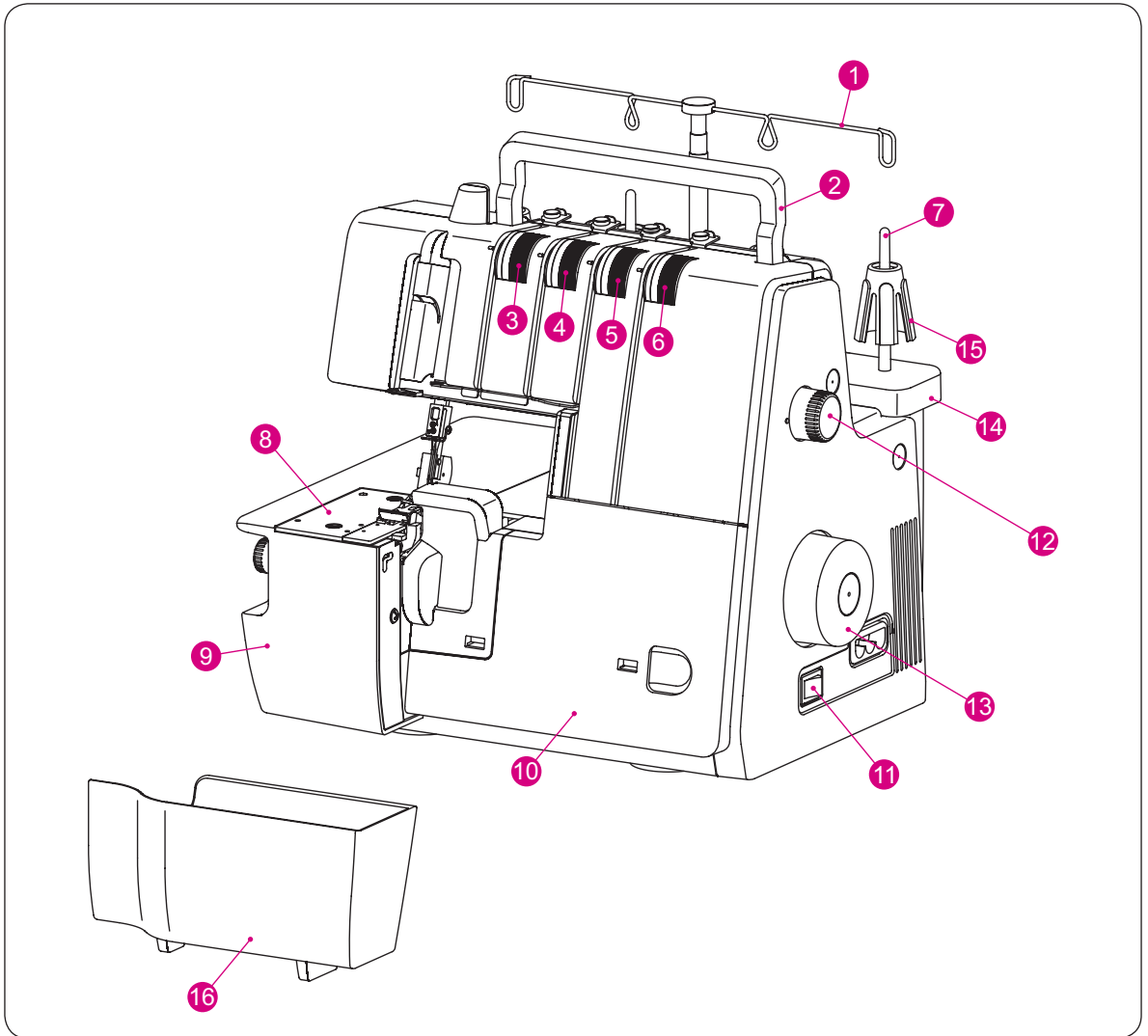

- |                                           |                        |
|-------------------------------------------|------------------------|
| ① Retractable thread stand                | ⑨ Sewing table         |
| ② Carrying handle                         | ⑩ Looper cover         |
| ③ Thread Tension Adjustment dial (yellow) | ⑪ Power / Light switch |
| ④ Thread Tension Adjustment dial (green)  | ⑫ Stitch length dial   |
| ⑤ Thread Tension Adjustment dial (blue)   | ⑬ Handwheel            |
| ⑥ Thread Tension Adjustment dial (red)    | ⑭ Thread stand         |
| ⑦ Spool pin                               | ⑮ Spool stabilizer     |
| ⑧ Stitch plate                            | ⑯ Cut-offs Bin         |

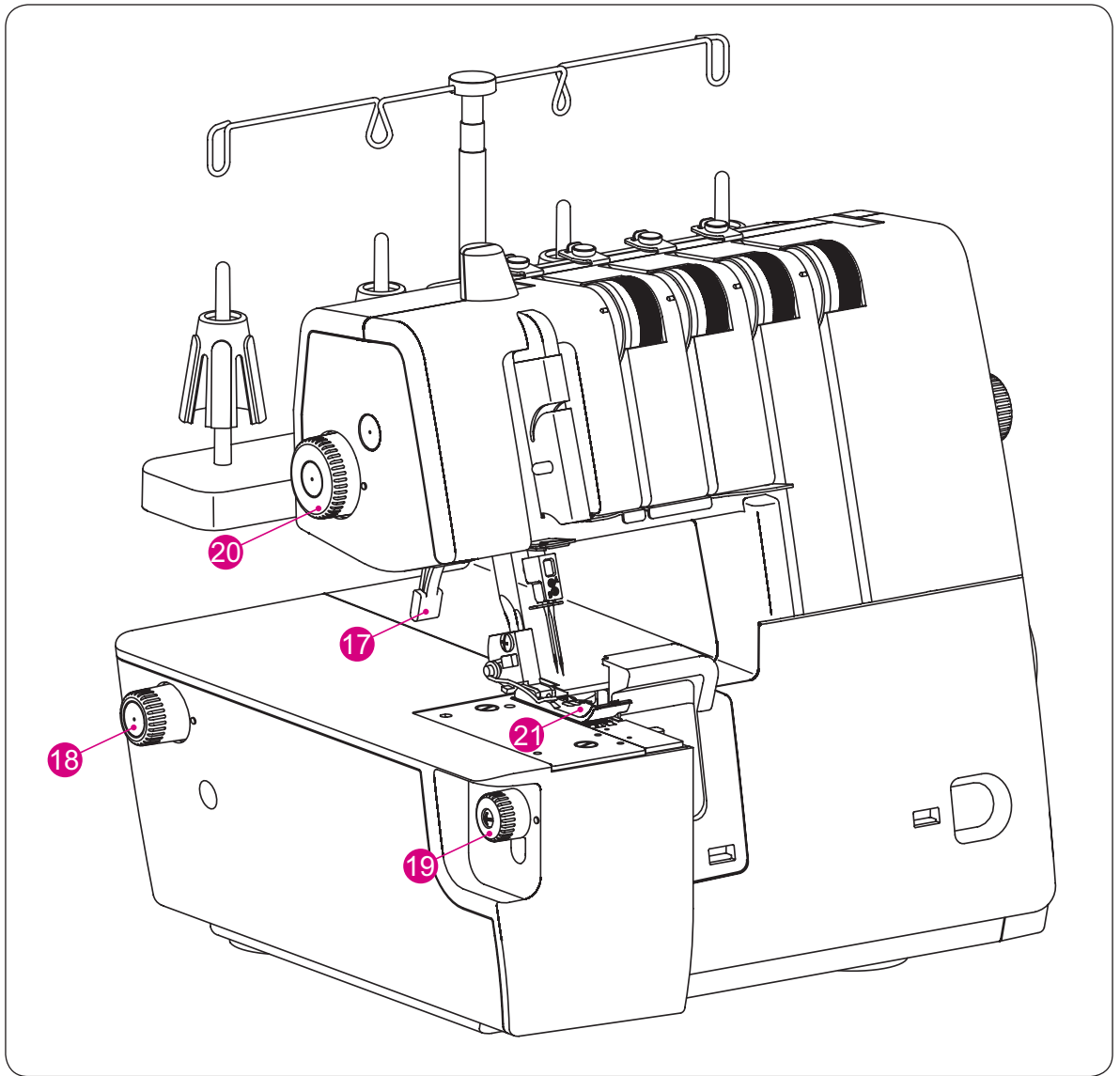

- ①⑦ Presser foot lifter
- ①⑧ Differential feed dial
- ①⑨ Cutting width dial
- ②⑩ Presser foot pressure regulator
- ②⑪ Standard presser foot Overlock

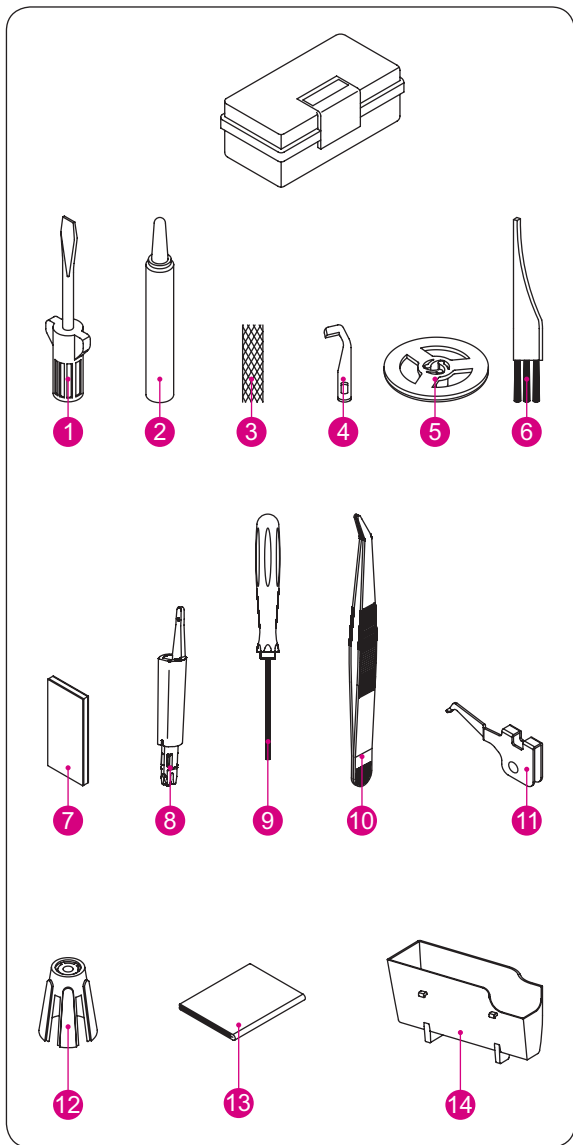

## ACCESSORIES

### Standard

- ① Screw driver (large size)
- ② Oiler
- ③ Spool net (4x)
- ④ Spare upper knife
- ⑤ Spool cap (4x)
- ⑥ Brush
- ⑦ Needle set (ELx705)
- ⑧ Needle Threader / inserter
- ⑨ Allen screw driver (small)
- ⑩ Tweezers
- ⑪ Upper looper converter (ULC)
- ⑫ Spool stabilizer (4x)
- ⑬ Dust cover
- ⑭ Cut-offs Bin

### Needle Information

This overlock uses a flat shank industrial needle (ELx705).

**Do not attempt to use a standard household sewing machine needle of any size or type in this overlock.**

Needle ELx705 size 80/12 is furnished with the machine.

**Only use needles of system ELx705 sizes 70/10 - 90/14.**

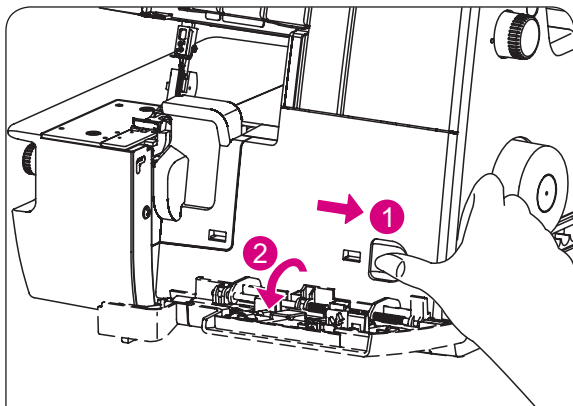

## HOW TO OPEN LOOPER COVER



### CAUTION:

Be sure to turn off power switch.

1. Push the cover to the right as far as it will go.
2. Pull cover down toward you.



### CAUTION:

Be sure looper cover is closed when sewing.

## Principal Parts behind the Looper Cover

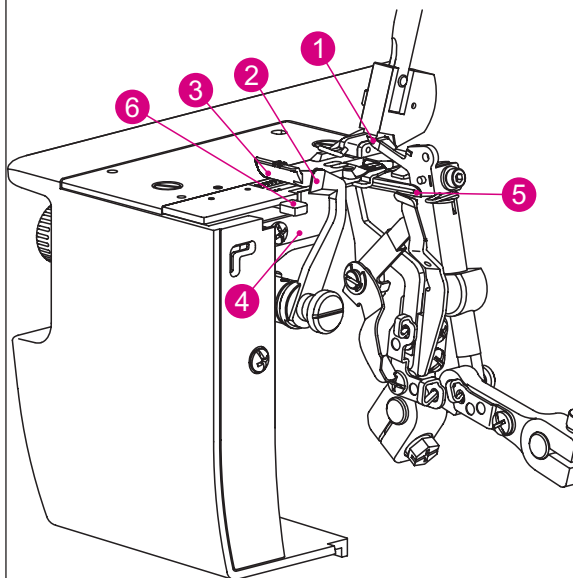

- (1) Upper looper
- (2) Upper knife (moveable)
- (3) Standard presser foot
- (4) Fixed position lower knife
- (5) Lower looper
- (6) Rolled Hem lever

## PREPARATION TO SEWING

### Power Switch

- Connect the controller/electric plug to the machine receptacle.
- Plug power line into electric outlet.
- Push "I" mark side to turn "ON"
- Push "O" mark side to turn "OFF"

### Foot Controller

- To run the machine and control the speed, press the controller.
- The harder you press, the faster the machine will sew.
- To stop the machine from sewing, remove your foot from the controller

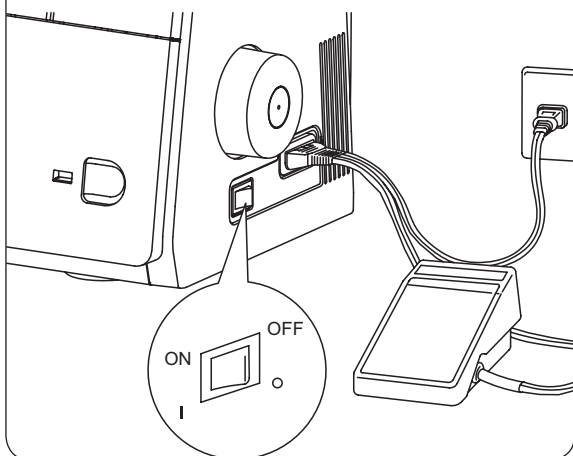

### CAUTION:

Use only foot controller provided with this machine. (Type 4C-316B for USA & CANADA only). Be sure to make reference to "Warning" on following Page.



## • Polarized plug information

(FOR USA & CANADA ONLY)

This appliance has a polarized plug (one blade wider than the other). To reduce the risk of electric shock, this plug is intended to fit in a polarized outlet only way. If the plug does not fit fully in the outlet, reverse the plug.

If it still does not fit contact a qualified electrician to install the proper outlet. Do not modify the plug in any way.



### CAUTION:

- Be sure that the electrical voltage of the electric outlet (wall receptacle) is the same as the rated voltage of the motor.
- Handle the foot controller with care and avoid dropping it on the floor. Be sure not to place anything on top of it when not in use.
- Disconnect the power line plug from the electric outlet when changing needles, presser feet or when leaving the machine unattended. This eliminates the possibility of starting the machine by accidentally pressing the controller.

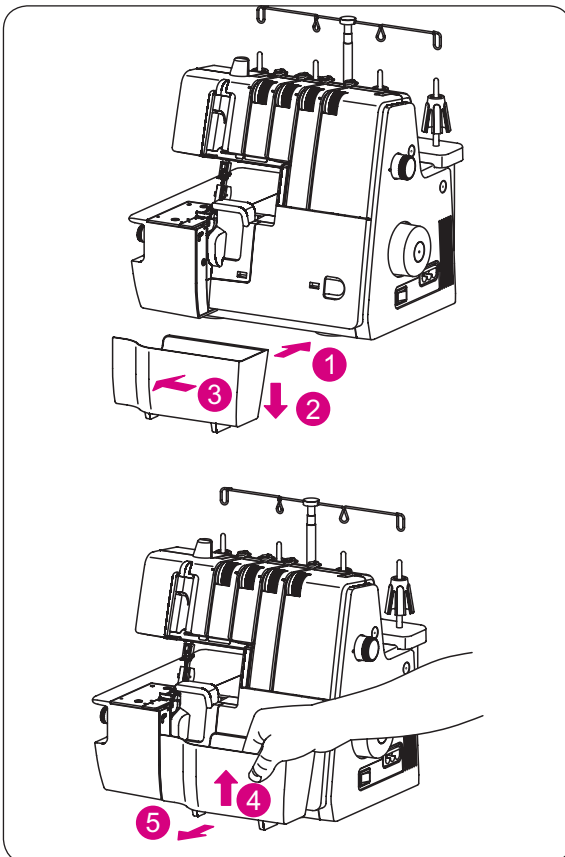

## Cut-offs Bin

### • To attach

- Insert the Cut-offs Bin (1) in the looper cover.
- Be sure to press the Cut-offs Bin downward (2).
- Be sure the left side of Cut-offs Bin (3) is mounted near the cutter where the scraps drop.

### • Removal

- Pull the Cut-offs Bin upward as the instruction (4).
- To remove (5), hold the Cut-offs Bin as shown and pull it outward.

## PREPARATION FOR THREADING

### Setting up the Retractable thread stand

- Take out the retractable thread stand from the top of Styrofoam, and insert it as shown on the left illustration.
- This machine is shipped with the retractable thread stand on the top of styrofoam.
- Fully extend the retractable thread stand.
- The two joints on the telescope will click into place when they are correctly positioned.
- Center the retractable thread stand above the spool pins.
- Place thread over the cone adapters on the spool pins.

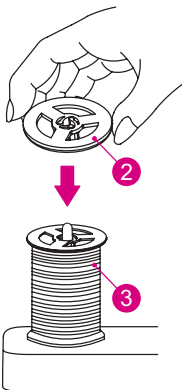
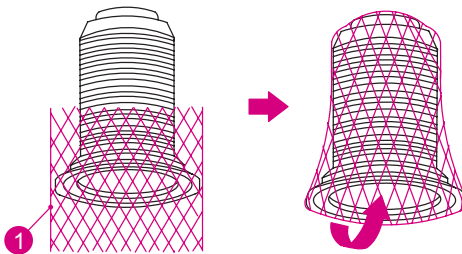
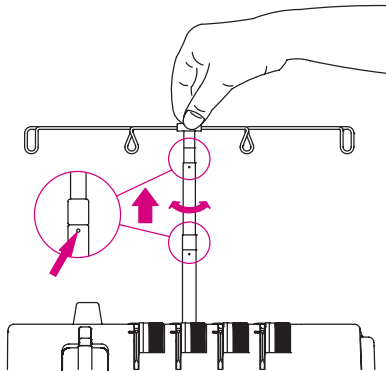
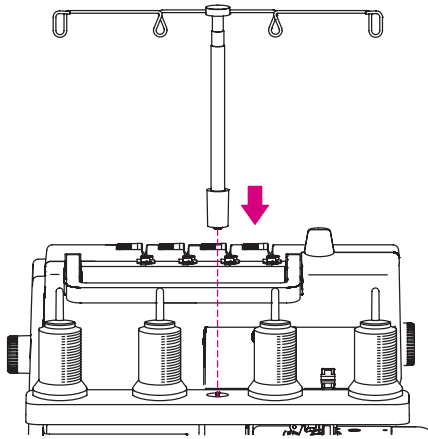

### Spool net

When using synthetic threads that easily spill off the cone, slip the spool net (1) furnished with the machine over the thread from the bottom of the cone leaving the thread end hanging free at the top the spool net.

### Spool Cap

When using a regular thread spool, fit the spool cap (2) supplied with the machine onto the thread spool (3).

## HOW TO DISENGAGE UPPER KNIFE



### CAUTION:

Be sure to turn off power switch.

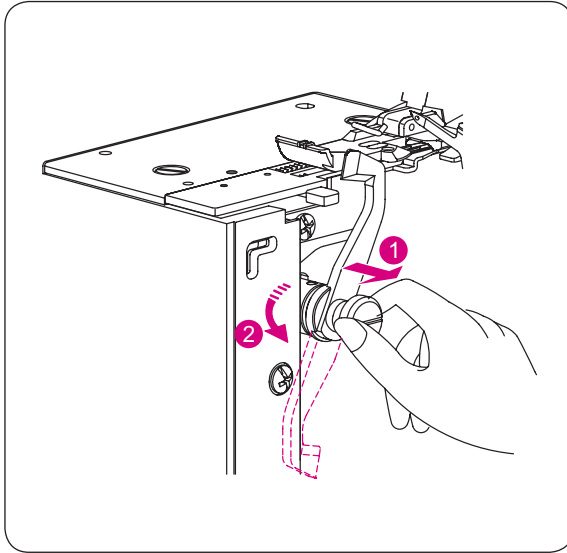

- **To place upper knife in nonworking position**

- Open looper cover (refer page 10).
- Pull the upper knife holder (1) to the right as far as it will go.
- Turn the holder (2) toward counter clockwise until the knife clicks into a lock position.

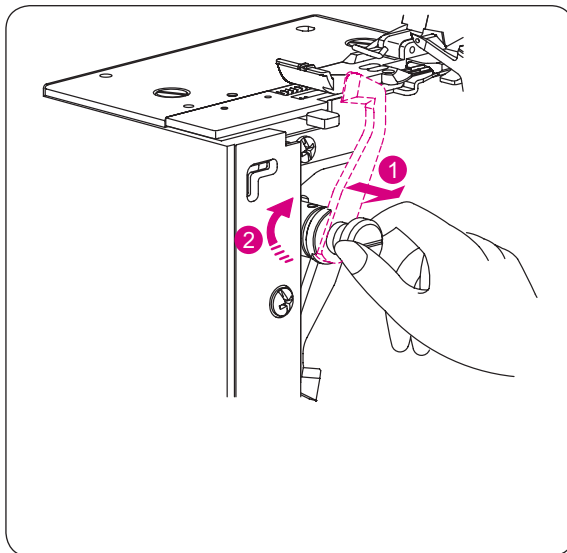

- **To place upper knife in working position**

- Open looper cover.
- Pull the upper knife holder (1) to the right as far as it will go.
- Turn the holder (2) clockwise until the knife clicks into the working position.



### CAUTION:

Always close looper cover before operating machine.

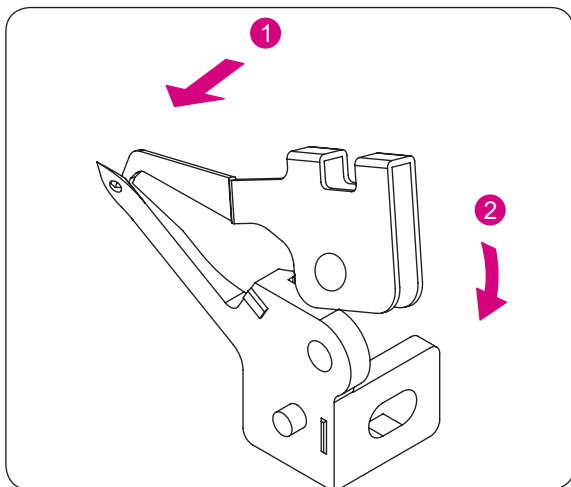

## UPPER LOOPER CONVERTER (ULC)



### CAUTION:

Be sure to turn off power switch.

When not threading the upper looper, the upper looper converter must be engaged into the upper looper eye.

### Attach the Upper Looper Converter

- To engage the upper looper converter, insert the sharp part (1) into the eye of upper looper.
- A raised point located in the trough of upper looper converter must be inserted and fixed (2) in the eye of the upper looper converter.

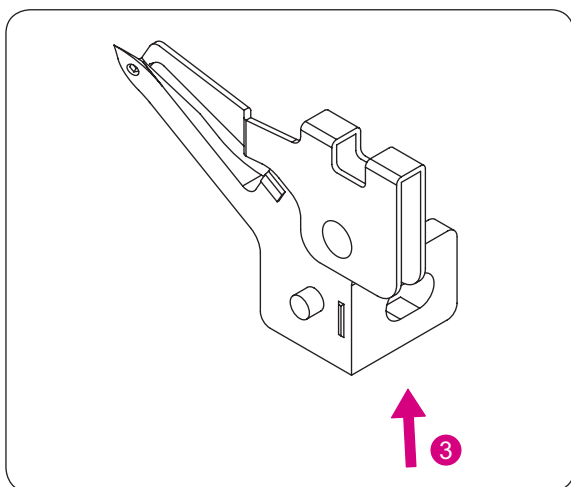

### Remove the Upper Looper Converter

When using the upper looper, the upper looper converter must be disengaged.

- To disengage the upper looper converter, raise the handle (3) of upper looper according to picture.

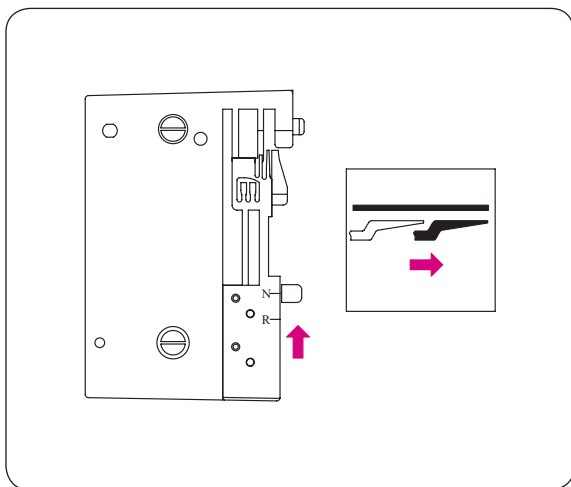

## STANDARD OVERLOCK AND ROLLED HEM STITCHING

### Sew Standard Overlock

Set seam width finger knob to "N" to move seam width finger to standard overlock sewing position.



### PLEASE NOTE:

Be sure to push seam width finger knob as far as it will go in the direction of setting "N".

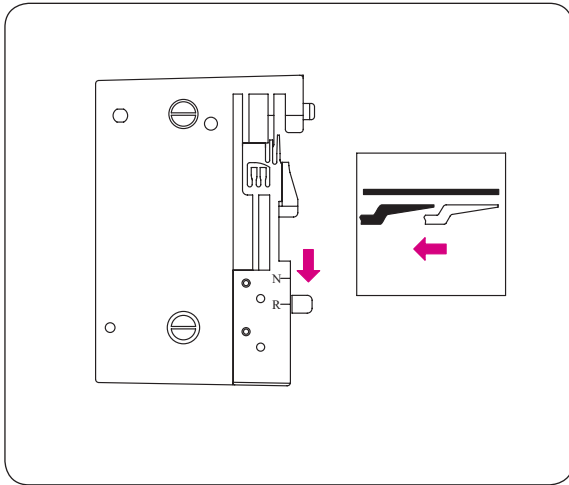

## Sew Rolled Hem

Set seam width finger knob to "R" to retract the seam width finger and set it for rolled hem.

### PLEASE NOTE:

Be sure to push seam width finger knob as far as it will go in the direction of setting "R".

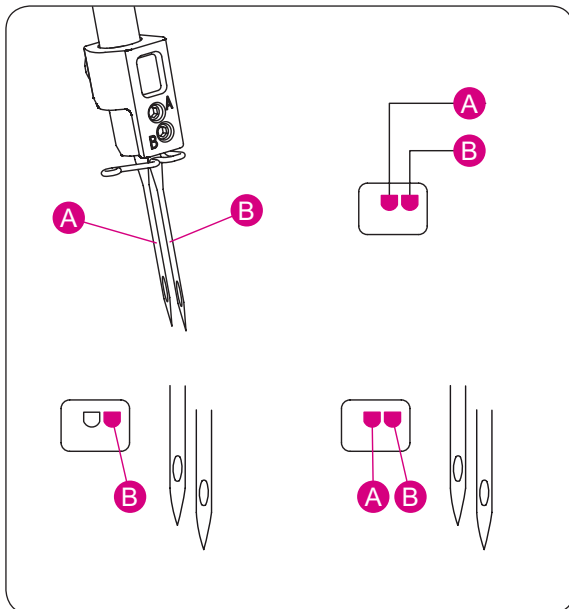

## HOW TO REMOVE AND INSERT NEEDLES

### Needle Position

- With this machines, two needles can be inserted to the needle clamp.
- The Stitch overview refers to different needle positions by illustrating the needle clamp.

### PLEASE NOTE:

When both the left and right overlock needles are inserted, the left needle will be slightly higher than the right.

- (A) Left Needle (LN)
- (B) Right Needle (RN)

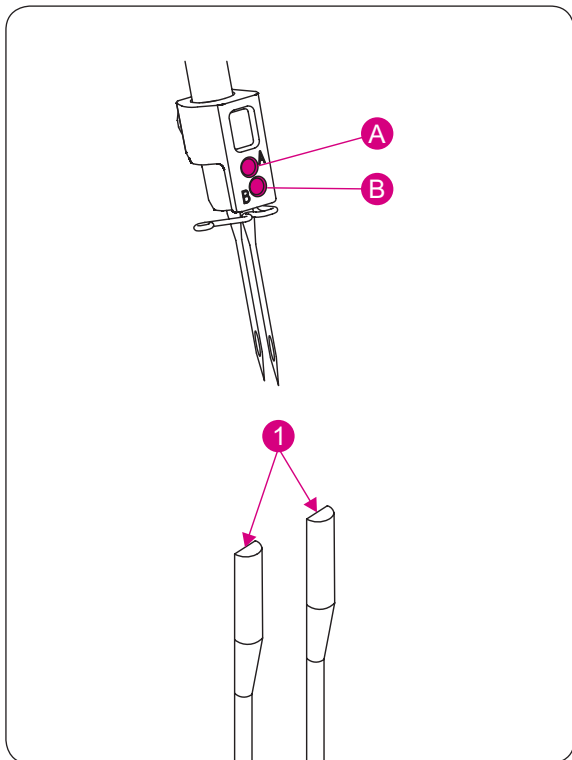

## To Remove Needle(s)

### PLEASE NOTE:

Be sure to disconnect the machine from the electric outlet before removing needle(s).

- Turn the hand wheel counterclockwise until the needles are at their highest position.
- Hold the needle to be removed with the needle holder (stored in the looper cover).
- Loosen the setscrew and remove the needle.

(A) Left needle (LN)

(B) Right needle (RN)

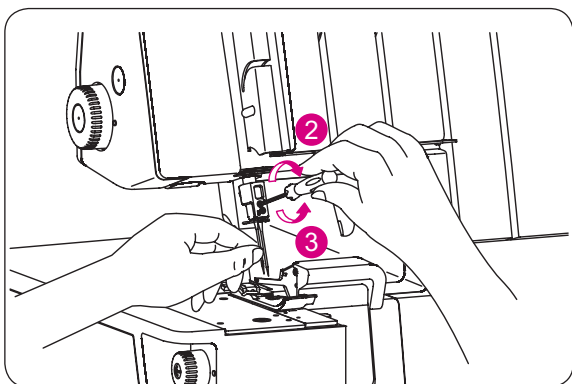

## To Insert Needle(s)

- Hold the needle with the flat surface (1) to the back.
- Insert the needle into the needle socket as far as it will go.
- When inserting a needle, if you first lower it down into the hole in the stitch plate it will line up with the needle socket. Then direct it upwards.

### PLEASE NOTE:

When inserting needles into the (A) or (B) sockets it is necessary to loosen (3) both (A) and (B) Allen Screws.

After inserting the needles equally tighten both Screws (2).



# STITCH OVERVIEW

This machine is capable of producing various types of stitches according to the combination of needle positions, threading methods, tension adjustment and the use of upper looper converter ULC.

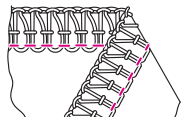
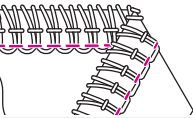
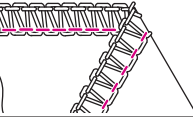
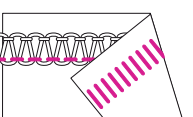
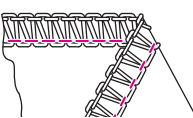
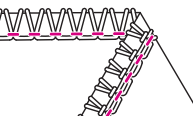
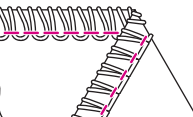
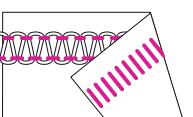
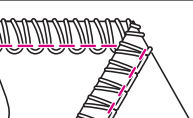
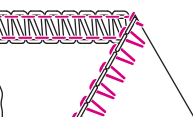
#	Stitch Type		Use	Page
1	4-Thread Overlock with integrated safety seam		2-needle 4-Thread stitch that is ideal for medium to heavyweight stretchy fabrics such as double knits and swim wear.	38
2	3-Thread Super Stretch		2-needle 3-Thread stitch that is ideal for light weight, extremely stretchy fabrics such as tricot and spandex.	37
3 4	3-Thread Overlock wide 3-Thread Overlock narrow		1-needle 3-Thread stitch is used for overedging and seaming on common fabrics. A 4 mm and 6 mm overlock seam width can be obtained by changing the needle position.	34
5 6	3-Thread Flatlock wide 3-Thread Flatlock narrow		1-needle 3-Thread stitch is used for butted or lapped seams and ornamental stitching with decorative thread. Also a 4 mm and 6 mm flatlock width can be obtained by changing the needle position.	35
7	3-Thread Narrow Seam		1-needle 3-thread stitch is for edging light weight fabrics.	41
8	3-Thread Rolled Hem		1-needle 3-thread stitch is used for sewing narrow rolled hems. For a beautiful rolled hem, thread the upper looper with decorative thread and the needle and lower looper with light weight regular thread.	41
9 10	2-Thread Wrapped Overlock wide 2-Thread Wrapped Overlock narrow		1-needle 2-Thread stitch is used for seaming light weight or stretch fabrics. A 4 mm and 6 mm overlock seam width can be obtained by changing the needle position.	32
11 12	2-Thread Flatlock wide 2-Thread Flatlock narrow		1-needle 2-Thread stitch is used for butted or lapped seams and ornamental stitching with decorative thread. Also a 4 mm and 6 mm flatlock width can be obtained by changing the needle position.	36
13	2-Thread Rolled Hem		1-needle 2-thread stitch is used for fine rolled hems.	42
14 15	2-Thread Overlock wide 2-Thread Overlock narrow		1-needle 2-Thread stitch is used for overedging common fabrics. A 4 mm and 6 mm overlock seam width can be obtained by changing the needle position.	33

Depending on the needle positions used, this machine can sew 2-/3- and 4-Thread Overlock Stitches at a width of 4mm and 6 mm.

Also, for overedging heavyweight fabrics, the seam width can be increased still more by turning the cutting width dial. (Refer page 27).

Overlock width	4.0 mm (narrow)	6.0 mm (wide)
Needle used	Overlock right needle	Overlock left needle
Needle thread tension dial	Green	Yellow
SL = Stitchlength DF = Differential feed dial CW = Cutting Width RHP = Rollhemlever position NP = Needle Position LN = Left Needle RN = Right Needle UL = Upper Looper LL = Lower Looper		

Stitch Type		Suggested Machine Settings					Thread Tension			
		SL	DF	CW	RHP	NP	Yellow	Green	Blue	Red
1	4-Thread Overlock with integrated safety seam	2.5	1	6	N		4.0	4.0	4.0	4.0
2	3-Thread Super Stretch	2.5	1	6	N		4.0	4.0		3.5
3	3-Thread Overlock wide	2.5	1	6	N		3.0	-	4.0	3.5
4	3-Thread Overlock narrow	2.5	1	6	N		-	4.0	4.0	4.0
5	3-Thread Flatlock wide	2.5	1	6	N		0.0	-	4.0	7.5
6	3-Thread Flatlock narrow	2.5	1	6	N		-	0.0	4.5	7.5
7	3-Thread Narrow Seam	1.5	1	5	R		-	4.0	5.0	4.5
8	3-Thread Rolled Hem	1	1	5	R		-	4.0	4.5	6.5
9	2-Thread Wrapped Overlock wide	2.5	1	6	N		2.5	-		3.0
10	2-Thread Wrapped Overlock narrow	2.5	1	6	N		-	4.5		3.5
11	2-Thread Flatlock wide	2.5	1	6	N		0.0	-		4.0
12	2-Thread Flatlock narrow	2.5	1	6	N		-	0.0		4.5
13	2-Thread Rolled Hem	1	1	5	R		-	4.5		4.0
14	2-Thread Overlock wide	2.5	1	6	N		0.0	-		4.0
15	2-Thread Overlock narrow	2.5	1	6	N		-	0.0		4.5

The thread tension becomes tighter as the dials are tuned to higher numbers. The tension settings shown on this page as well as throughout the Instruction book are suggested default settings.

Adjust thread tensions to suit the fabric and size of thread of thread used. For best results make tension adjustments in small increments of no greater than half a number at a time.

# THREADING THE MACHINE

## Threading Diagram

- **Overlock Stitches**

- A color coded threading diagram is located inside the looper cover for quick reference.
- Thread the machine in the order (1)-(4).

**PLEASE NOTE:**

Threads go through the take-up lever cover for Overlock as shown.

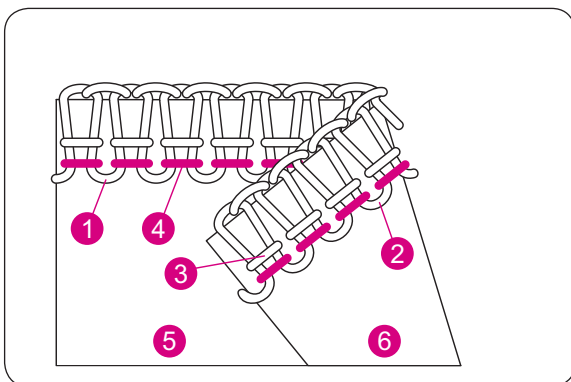
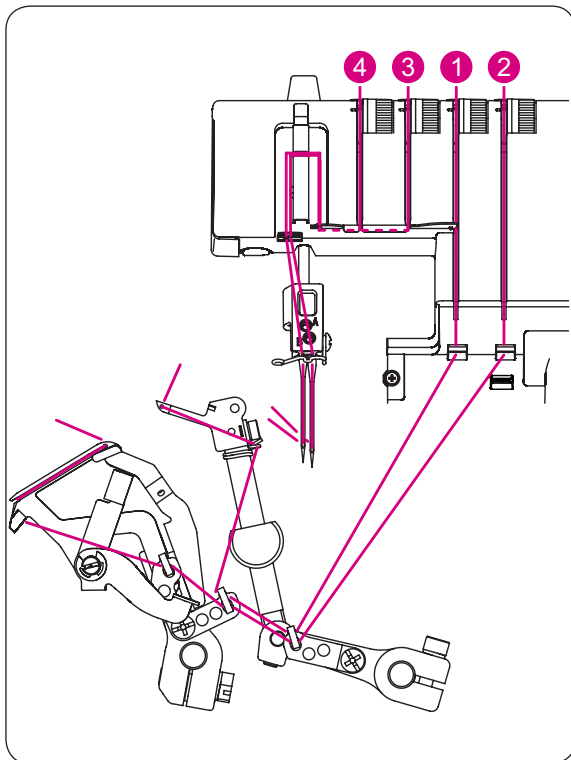

## Tension Color Code

- **Overlock Stitches**

- (1) Upper looper thread (Blue)
- (2) Lower looper thread (Red)
- (3) Right needle thread (Green)
- (4) Left needle thread (Yellow)
- (5) Topside of fabric
- (6) Underside of fabric

## Threading the Upper Looper (Blue)



### CAUTION:

Be sure to turn off power switch.

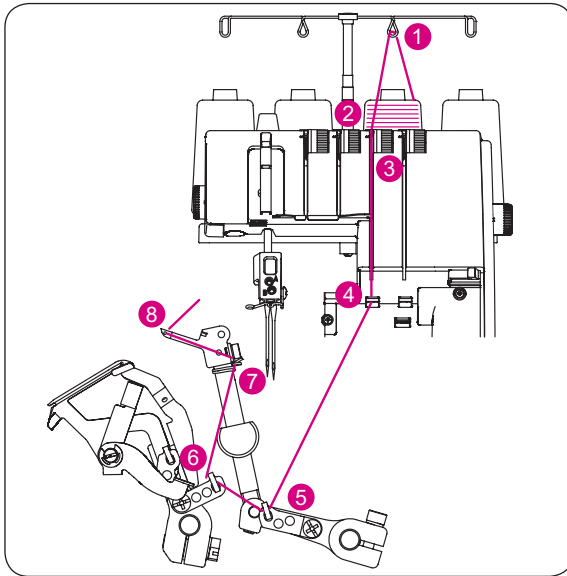

- Raise the presser foot to open the tension discs.
- Thread the upper looper as indicated (1)–(8).

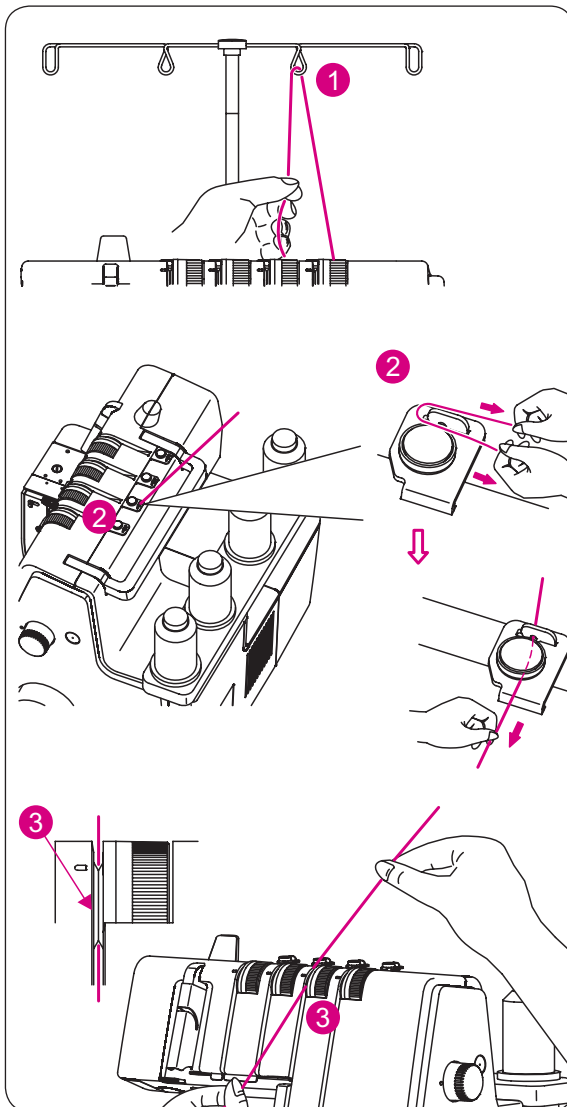

- Pass thread from back to the front through the thread guide (1).
- Thread the pre-tension guide by pulling the thread towards the left until it slips under guide (2). Then pull thread along the right side of pre-tension as illustrated.
- While holding thread with fingers, pass it between the tension discs and pull thread down to make certain it is properly located in between the tension discs (3).

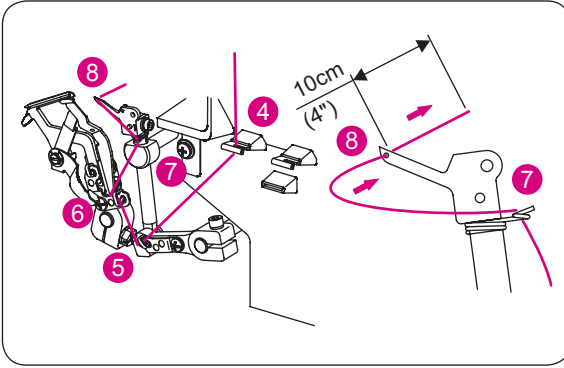

- Thread the looper area of the machine following the blue color coded thread guides (4)–(8).
- Thread the upper looper eye from front to back (8).

**PLEASE NOTE:**

Make sure thread passes behind lower looper.

Use tweezers provided in the accessory case to aid in threading the looper.

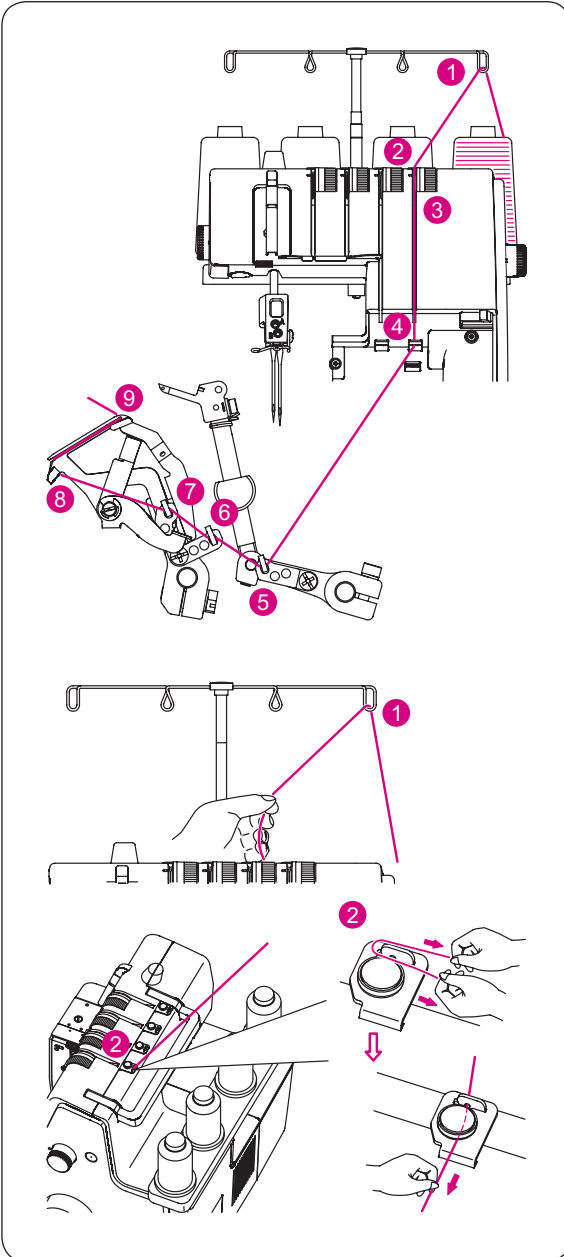

**Threading the Lower Looper (Red)**

- Raise the presser foot to open the tension discs.
- Thread the lower looper as indicated (1)–(9).

- Pass thread from back to the front through the thread guide (1).

- Thread the pre-tension guide by pulling the thread towards the left until it slips under guide (2). Then pull thread along the right side of pre-tension as illustrated.

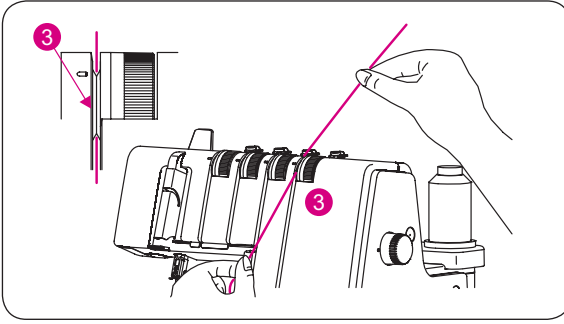

- While holding thread with finger, pass it between the tension discs and pull thread down to make certain it is properly located in between the tension discs (3).
- Turn the handwheel anticlockwise until the lower looper extends out 5–10 mm from the stitch plate edge.

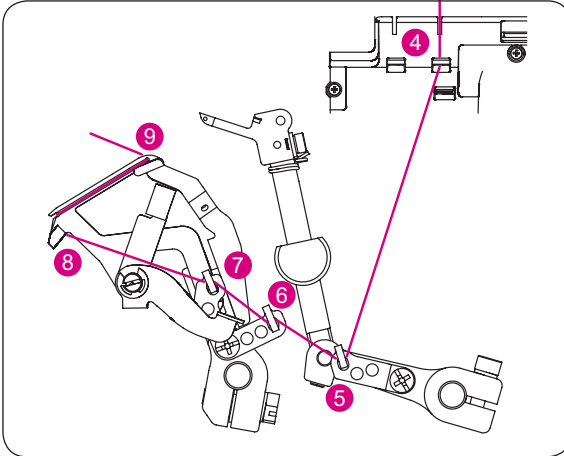

- Thread the looper area of the machine following the red color coded thread guides (4)–(9).

**PLEASE NOTE:**

Use tweezers provided in the accessory case to aid in threading the looper.

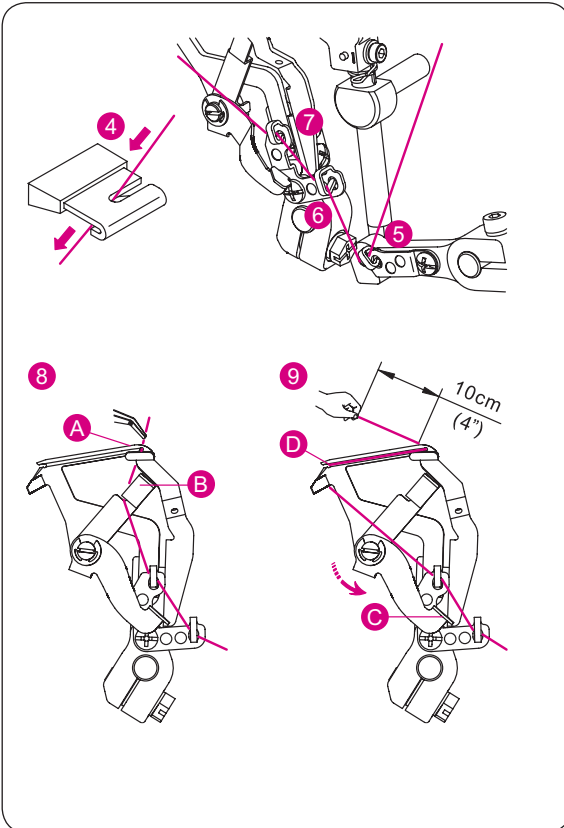

- Place the thread with the point of the tweezers slightly from left and to the right of threading guide (4).

- Thread the looper eye (A) from front to back.
- Pull about 4" (10 cm) of thread.
- Position thread into V cutout (B) on threader.
- Firmly hold thread tail with left hand and pull Threader lever (C) up into place (D).



## Threading the Overlock Right Needle (Green)

(B On Needle Clamp)



### CAUTION:

Be sure to turn off power switch.

- Raise the presser foot to open the tension discs.
- Thread the right needle as indicated (1)–(9).

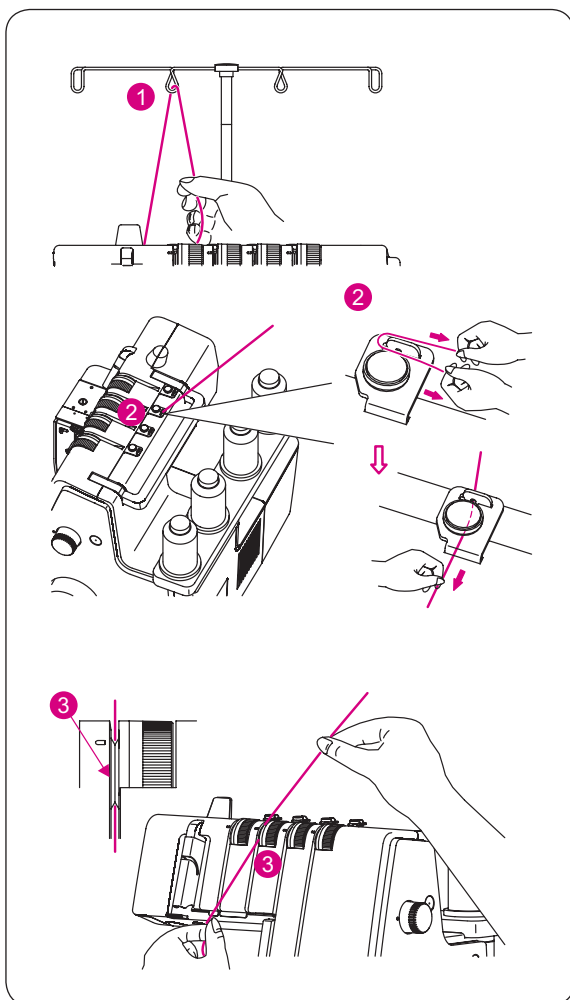
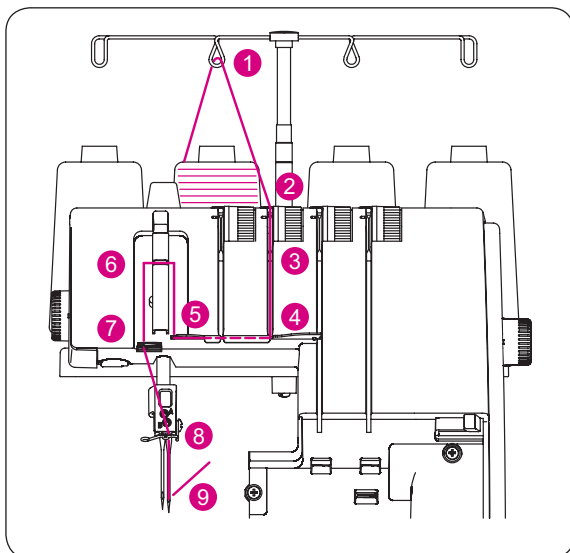

- Pass thread from back to the front through the thread guide (1).
- Thread the pre-tension guide by pulling the thread towards the left until it slips under guide (2). Then pull thread along the right side of pre-tension as illustrated.
- While holding thread with fingers, pass it between the tension discs and pull thread down to make certain it is properly located in between the tension discs (3).

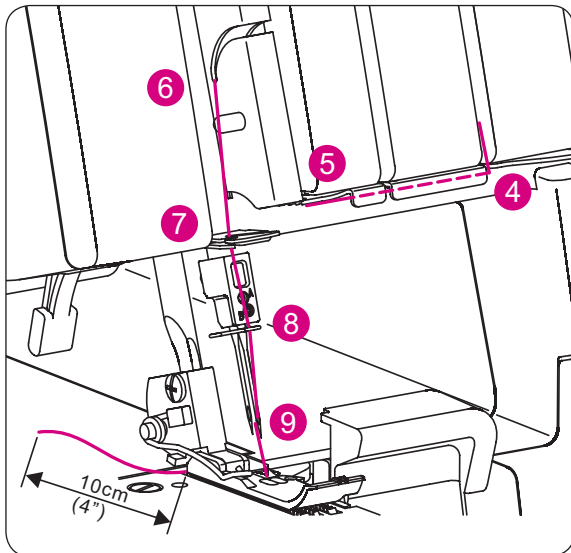

- Continue to thread points (4)–(9).

**PLEASE NOTE:**

Slip thread into the rear slot on the thread guide (5) and bottom slot of take-up lever cover (6). Then slip thread into the right slot on the thread guide (7), and into the right slot on the thread guide (8).

Before threading eye of needle, slip thread behind thread guide located on the bottom of the needle clamp.

- Thread the eye of the right needle (9).

**PLEASE NOTE:**

Use of tweezers in the accessory case will make needle eye threading easy.

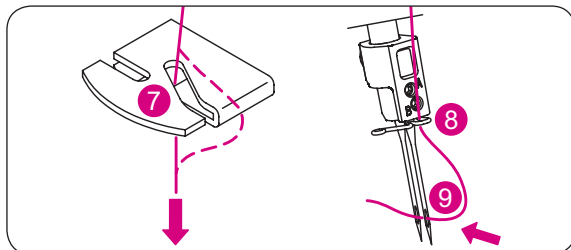

- The position of the thread must be behind the thread guide.
- Draw about 4" (10 cm) of thread through needle eye towards the rear of machine.
- Place the thread to the back, under the presser foot.

**Threading the Overlock Left Needle (Yellow)**

(A On Needle Clamp)

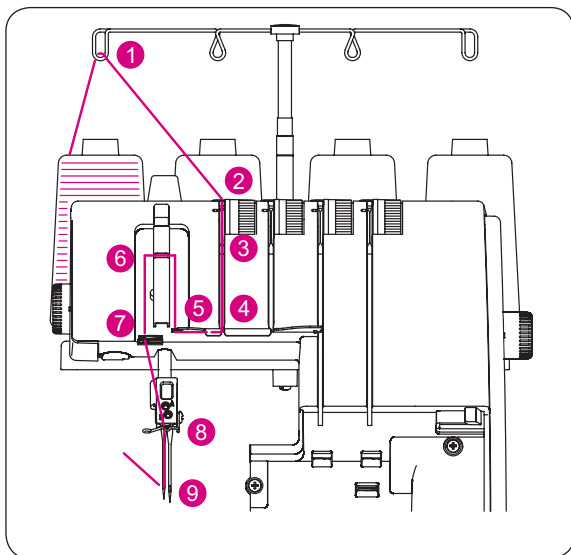

**CAUTION:**

Be sure to turn off power switch.

- Raise the presser foot to open the tension discs.
- Thread the left needle as indicated (1)–(9).

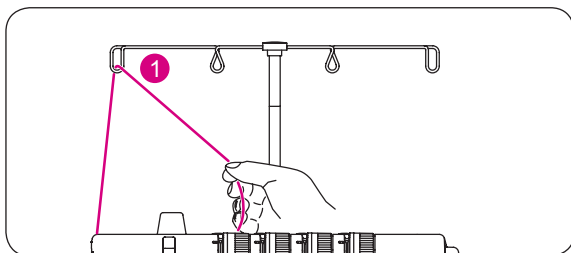

- Pass thread from back to the front through the thread guide (1).

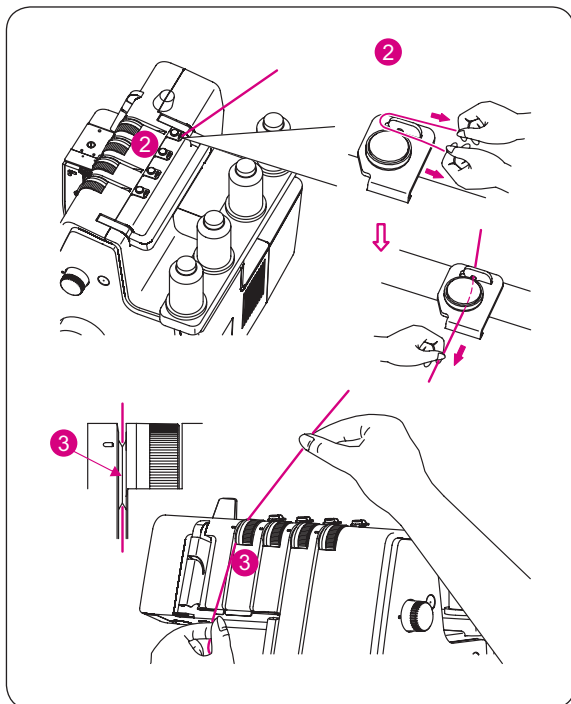

- Thread the pre-tension guide by pulling the thread towards the left until it slips under guide (2). Then pull thread along the right side of pre-tension as illustrated.

- While holding thread with fingers, pass it between the tension discs and pull thread down to make certain it is properly located in between the tension discs (3).

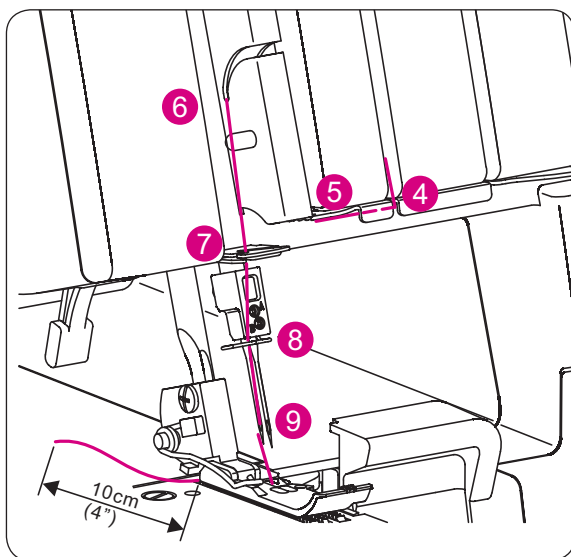

- Continue to thread points (4)-(9).

**PLEASE NOTE:**

Slip thread into the front slot on the thread guide (5) and bottom slot of take-up lever cover (6). Then slip thread into the left slot on the thread guide (7), and into the left slot on the thread guide (8).

Before threading eye of needle, slip thread behind thread guide located on the bottom of the needle clamp.

- Thread the eye of the left needle (9).

**PLEASE NOTE:**

Use of tweezers in the accessory case will make needle eye threading easy.

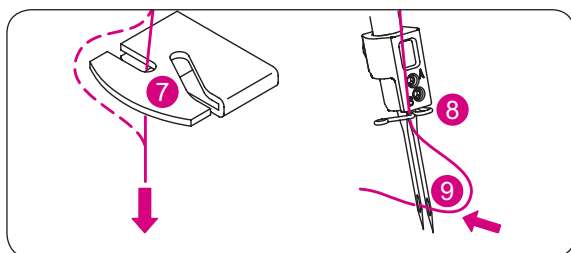

- The position of the thread must be behind the thread guide.
- Draw about 4" (10 cm) of thread through needle eye towards the rear of machine.
- Place the thread to the back, under the presser foot.

## HOW TO CHANGE THREADS

### Tie on method

- To change thread type or color, clip thread near the spool.

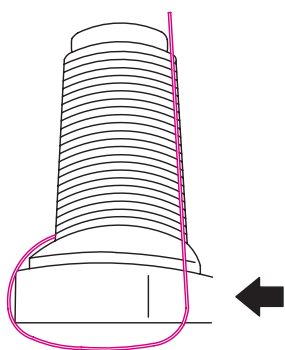
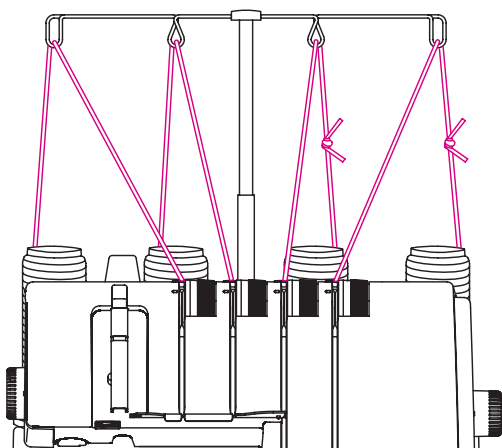
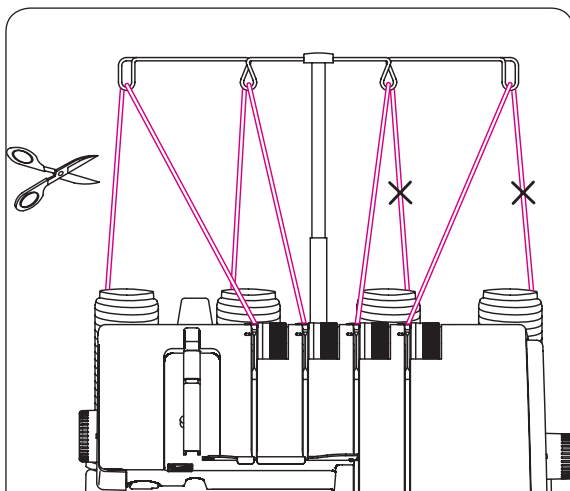

- Place new thread on stand.
- Tie new thread and old thread ends together with a square knot. Clip thread tails to 2–3cm (1") length. If clipped too short, threads may come untied.
- Firmly pull both thread to test knot security.
- Raise the presser foot to open the tension discs.

- Pull the threads through the machine once at a time.
- If threads do not pull easily, check for tangles on thread guides or looping under thread stand.
- When pulling thread through the needles, **STOP** when the knot is in front of the needle.
- Cut the knot and thread the needle eye.

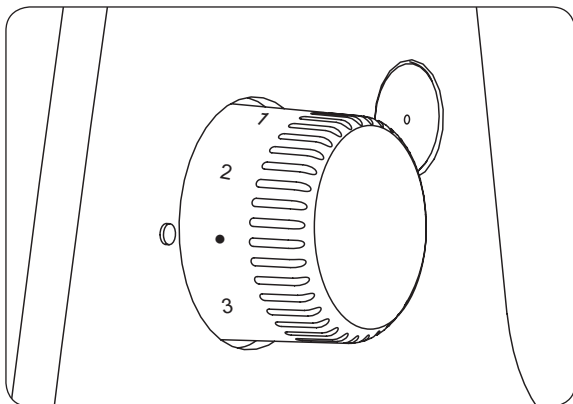

## HOW TO ADJUST

### Stitch length dial

- The stitch length dial should be set on the • = 2.5 setting for most sewing conditions.
- Adjust the stitch length to 2.5 – 4 when sewing heavy weight fabrics.
- For rolled hems and narrow seams set the stitch length between 1 and 2.
- A shorter stitch length can be used to avoid fabric from puckering.

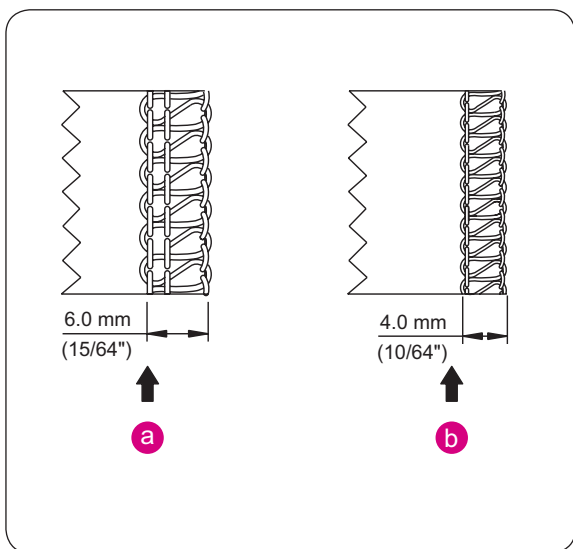

### Seam Width

Overlock seam width can be achieved by repositioning the needle position and also with the cutting width dial.

- **Width adjustment by changing needle position**

Overlock seam width can be adjusted by changing the needle position.

- (a) When using left needle  
6 mm (15/64")
- (b) When only right needle is used  
4 mm (10/64")

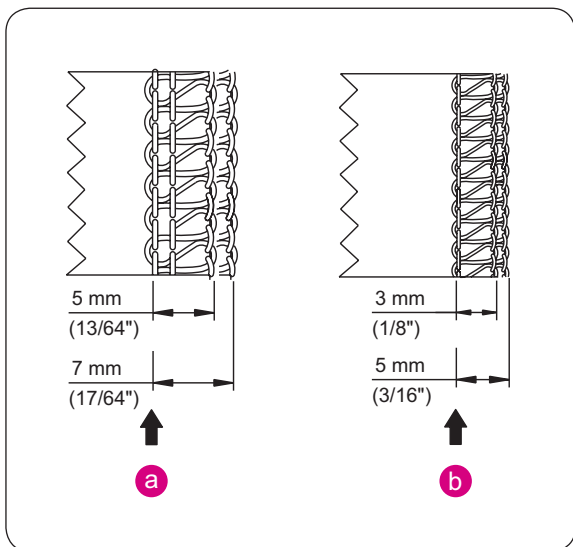

- **Cutting width dial**

Use of cutting width dial will permit further adjustment within the width range shown below.

- (a) When using left needle  
5–7 mm (13/64"–17/64")
- (b) When only right needle is used  
3–5 mm (1/8"–3/16")

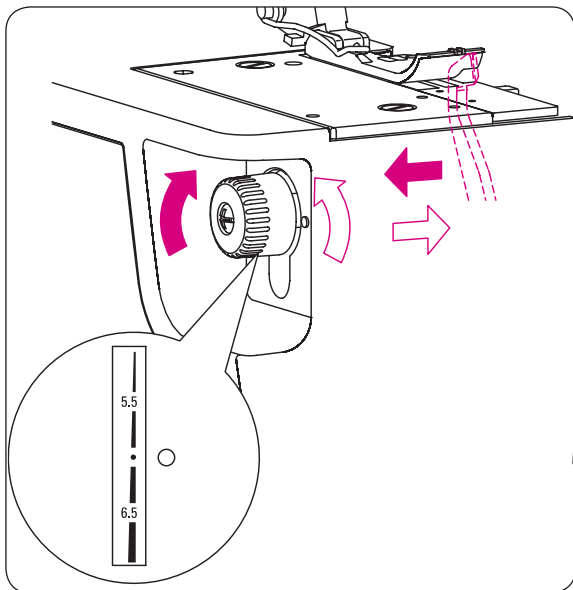

- Turn the cutting width dial counter clockwise to increase width of cutting, and clockwise to decrease width of cutting.

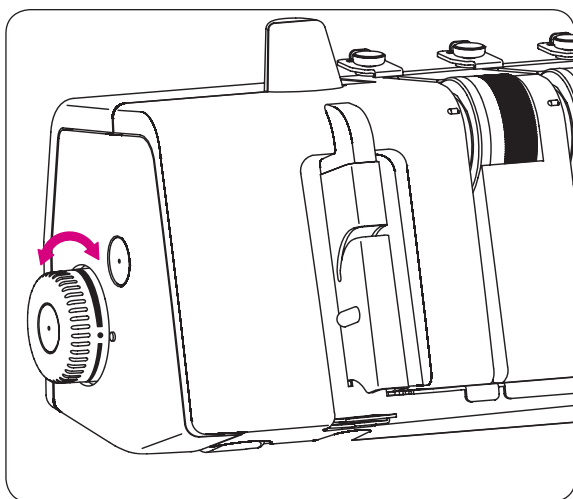

## The presser foot pressure

The presser foot pressure of this machine is pre-adjusted at the factory to suit the sewing of medium weight fabrics.

Most of the materials do not require adjustment of presser foot pressure. However, there are some instances where adjustment is necessary, such as when sewing light weight and heavyweight fabrics.

In such case, use "●" for normal, "L" for the lightest pressure, and "H" for the heaviest.

- For light weight fabric Decrease the pressure.
- For heavy weight fabric Increase the pressure.
- Testsew to define the optimal pressure for your sewing project.



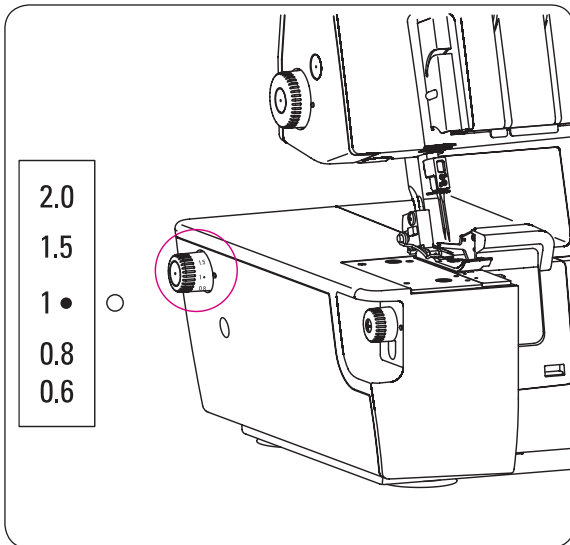

## DIFFERENTIAL FEED

- Differential feed is a system which "stretches" or "gathers" the fabric, when the amount of feed of front feed dogs in relation to the rear feed dogs is changed.
- The differential feed ratio ranges from 0.6–2.0. Adjustment is made by means of the differential feed dial pictured at left.
- Use of differential feed is very effective in over-edges stretch fabrics and fabrics cut on the bias.
- Setting "1" is differential feed dial setting for ratio 1:1.

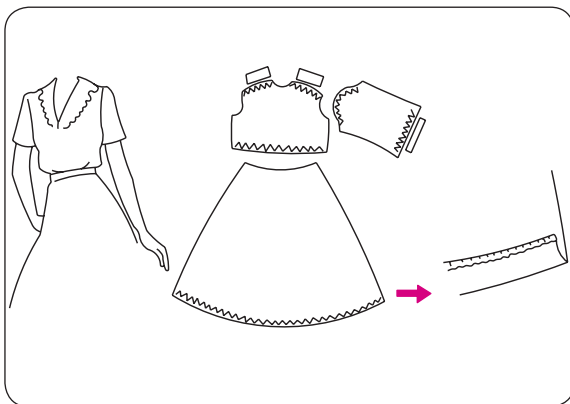

## Gathered Overlock (1–2.0)

Gathered overlock is most suited for shirring sleeves, yokes, front and back bodices, skirt hems, etc. in stretch fabrics such as well as knits and jersey before assembling into garment.

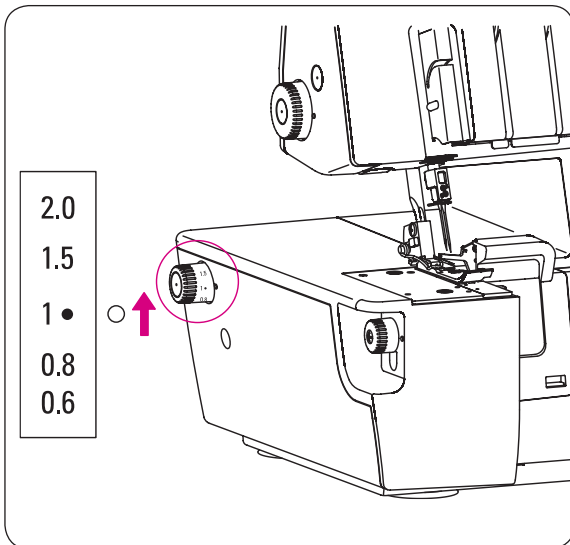

### • To set the differential feed dial for gathering

- Set differential feed dial above setting "1".
- Setting of adjusting dial depends on material being sewn as well as the amount of desired gather.
- Therefore set dial to suit the fabric and test sew before sewing your garment.

### PLEASE NOTE:

For normal overlock stitching, set differential feed dial to graduation "1".

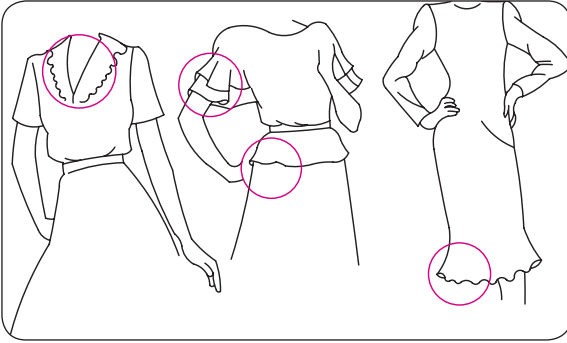

## Stretch Overlock (1–0.6)

Stretch overlock is ideal for sewing decorative collars, sleeves, skirt hems, etc. on loosely knit and woven fabrics. It is also used to prevent seam puckering in fine fabrics.

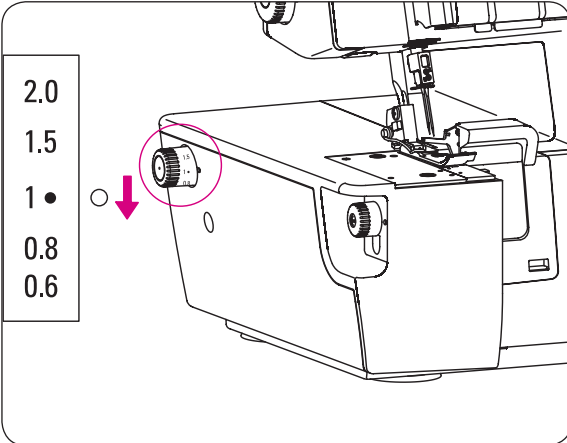

- **To set the differential feed dial for stretch**

- To stretch, set the differential feed between 1 and 0.6.

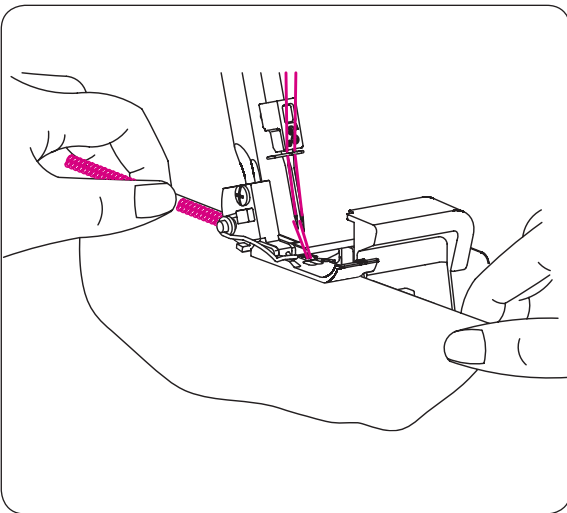

- To sew a seam, apply gentle tension to the fabric by holding the seam lightly in front and back of the presser foot.

### PLEASE NOTE:

If amount of “stretch” is not correctly set in relation to the fabric being sewn, the fabric is apt to shift away from the needle resulting in improperly sewn overlock seam.

In such case, reset differential feed dial closer to the center mark.

Be sure to reset the differential feed dial to graduation “1” for normal overlock stitching.

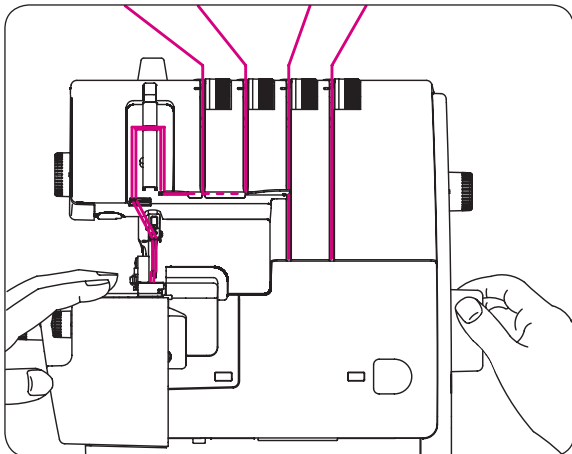

## CHAINING OFF AND TEST SEWING

- When the machine is completely threaded, bring all of the threads across the stitch plate and slightly to the left under the presser foot.
- Lower the presser foot to activate the thread tensions.
- Hold the threads and apply a slight tension.
- Turn the handwheel toward you 2 or 3 complete turns to start the thread chain.

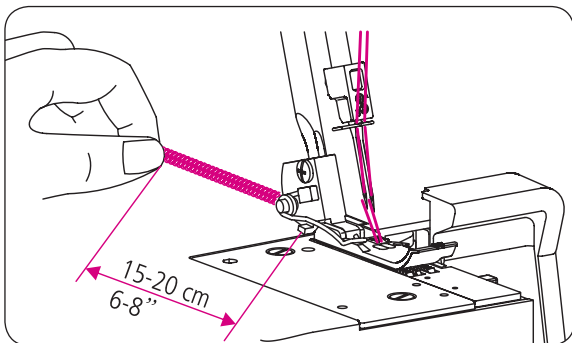

- Continue holding the chain and press on the foot controller until the chain is 5–7.5 cm (2–3") in length.
- Place fabric under the front of the presser foot and sew a test sample.

### PLEASE NOTE:

Do not pull on the fabric while sewing as this may deflect the needle, causing it to break.

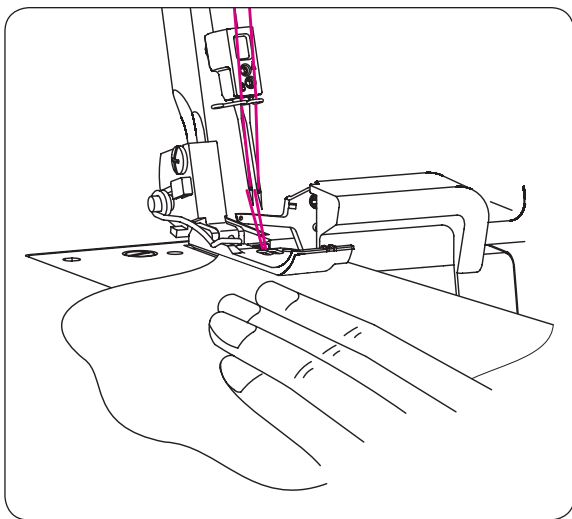

- At the end of the sample, continue to run the machine with the presser foot down until the chain reaches 15–20 cm (6–8") in length.

### PLEASE NOTE:

In case it is difficult to chain off and pull the fabric lightly backward.

- Cut threads.

### PLEASE NOTE:

Anytime you have rethreaded the machine always chain off and sew a text sample to test tensions and make adjustments as necessary.

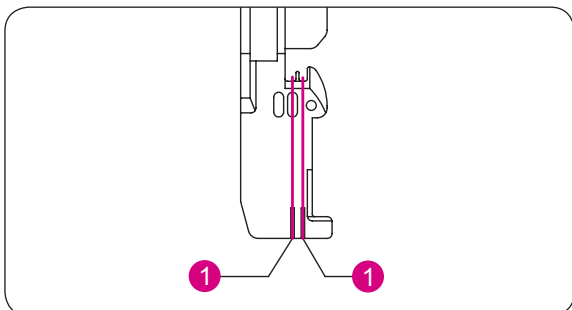

### Information

A mark (1) to indicate the needle location is provided on the presser foot fitted on this machine. Use this mark as a guide when sewing.

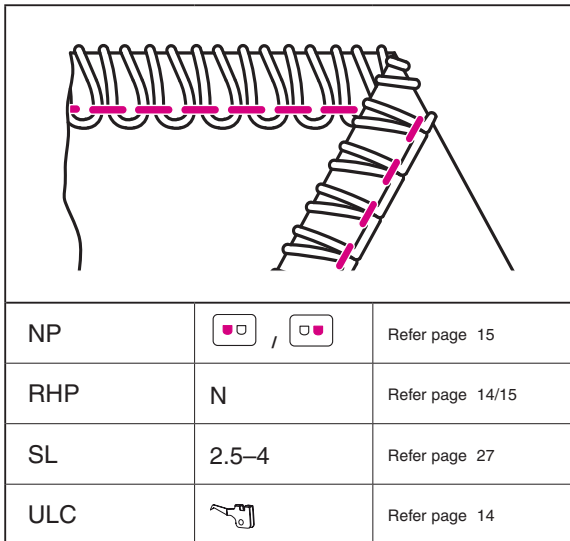

## HOW TO SEW AN OVERLOCK STITCH

### 2-Thread Wrapped Overlock (9/10)

#### PLEASE NOTE:

- These are suggested tension settings only.
- Tension settings are effected by;
  1. Type and thickness of fabric
  2. Needle size
  3. Size, type and fiber content of thread

#### • Correct balance

- Set each tension dial to recommended setting and test sew on a sample of your fabric.

Thread Color Code refer page 19.

#### 2-Thread Wrapped Overlock wide 9

Medium weight fabric	Thread tension			
	Yellow	Green	Blue	Red
	2.5			3.0

#### 2-Thread Wrapped Overlock narrow 10

Medium weight fabric	Thread tension			
	Yellow	Green	Blue	Red
		4.5		3.5

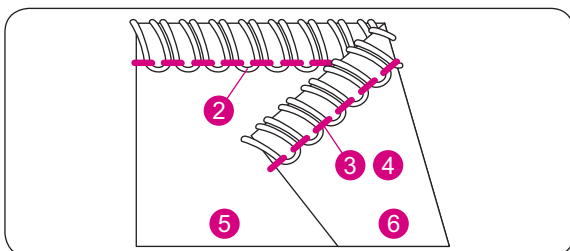
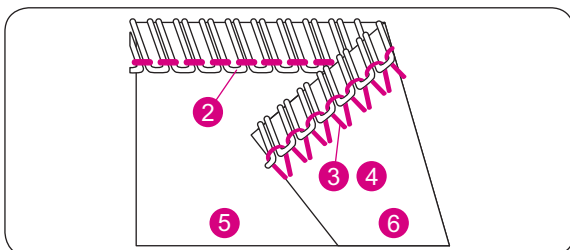

#### • How to balance the thread tension



When the lower looper thread tension is too tight or needle thread tension is too loose;

- Turn the lower looper thread tension dial (red) toward a lower number.
- Or, turn the needle thread tension dial (yellow or green) toward a higher number.

When the lower looper thread tension is too loose;

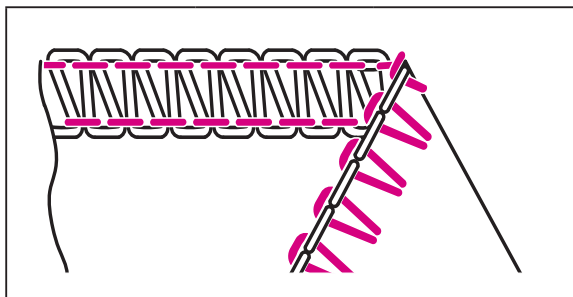
- Turn the lower looper thread tension dial (red) toward a higher number.



NP	 , 	Refer page 15
RHP	N	Refer page 14/15
SL	2.5–4	Refer page 27
ULC		Refer page 14

Thread Color Code refer page 19.

## 2-Thread Overlock (14/15)

### PLEASE NOTE:

- These are suggested tension settings only.
- Tension settings are effected by;
  1. Type and thickness of fabric
  2. Needle size
  3. Size, type and fiber content of thread

### • Correct balance

- Set each tension dial to recommended setting and test sew on a sample of your fabric.

### 2-Thread Overlock wide 14

Medium weight fabric	Thread tension			
	Yellow	Green	Blue	Red
	0.0			4.0

### 2-Thread Overlock narrow 15

Medium weight fabric	Thread tension			
	Yellow	Green	Blue	Red
		0.0		4.5

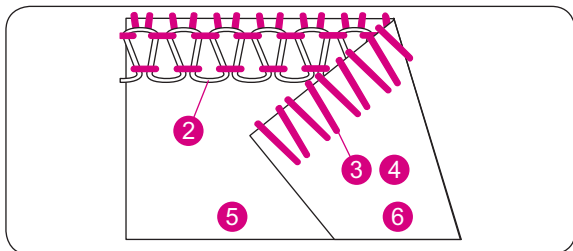
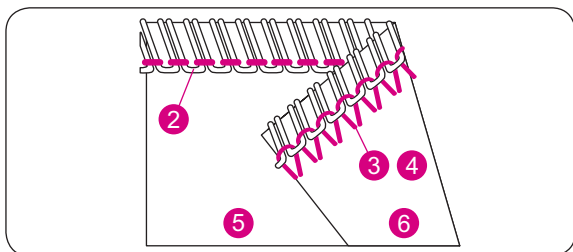

### • How to balance the thread tension

When the lower looper thread lies on the underside of the fabric;

- Turn the lower looper thread tension dial (red) toward a higher number.

When the needle thread tension is too loose;

- Turn the needle thread tension dial (yellow or green) toward a higher number.
- Or, turn the lower looper thread tension dial (red) toward a lower number.

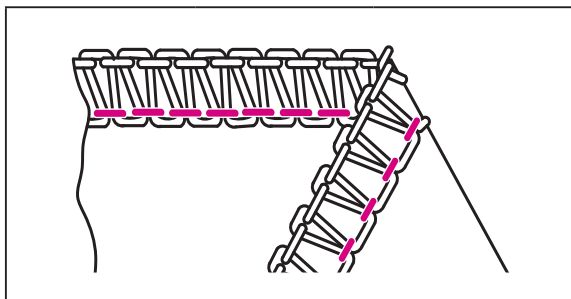

NP	/	Refer page 15
RHP	N	Refer page 14/15
SL	2.5–4	Refer page 27
ULC	-	Refer page 14

Thread Color Code refer page 19.

### 3-Thread Overlock (3/4)

#### PLEASE NOTE:

- These are suggested tension settings only.
- Tension settings are effected by;
  1. Type and thickness of fabric
  2. Needle size
  3. Size, type and fiber content of thread

#### • Correct balance

- Set each tension dial to recommended setting and test sew on a sample of your fabric.

#### 3-Thread Overlock wide 3

Medium weight fabric	Thread tension			
	Yellow	Green	Blue	Red
	<b>3.0</b>		<b>4.0</b>	<b>3.5</b>

#### 3-Thread Overlock narrow 4

Medium weight fabric	Thread tension			
	Yellow	Green	Blue	Red
		<b>4.0</b>	<b>4.0</b>	<b>4.0</b>

#### • How to balance the thread tension

When the upper looper thread lies on the underside of the fabric;

- Turn the upper looper thread tension dial (blue) to a higher number.
- Or, turn the lower looper thread tension dial (red) to a lower number

When the lower looper thread appears on the top of the fabric;



- Turn the lower looper thread tension dial (red) toward a higher number.
- Or, turn the upper looper thread tension dial (blue) to a lower number.

When the needle thread is too loose;

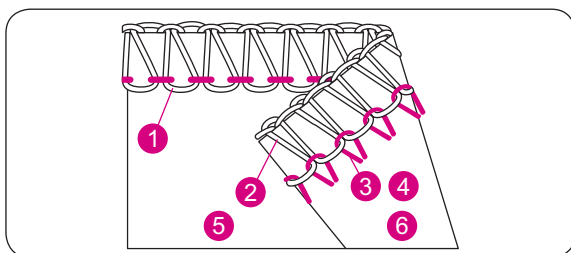
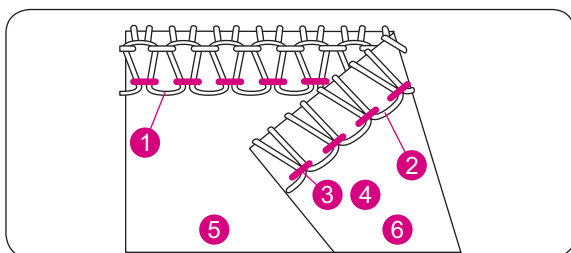
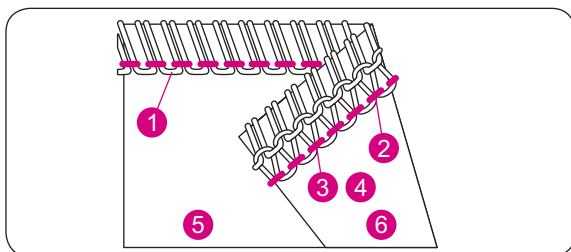
- Turn the needle tension dial (yellow or green) to a higher number.

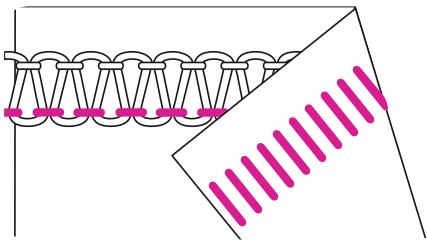



NP	 , 	Refer page 15
RHP	N	Refer page 14/15
SL	2.5–4	Refer page 27
ULC	-	Refer page 14

Thread Color Code refer page 19.

### 3-Thread Flatlock (5/6)

#### PLEASE NOTE:

- These are suggested tension settings only.
- Tension settings are effected by;
  1. Type and thickness of fabric
  2. Needle size
  3. Size, type and fiber content of thread

#### • Correct balance

- Set each tension dial to recommended setting and test sew on a sample of your fabric.

#### 3-Thread Flatlock wide 5

Medium weight fabric	Thread tension			
	Yellow	Green	Blue	Red
	0		4.0	7.5

#### 3-Thread Flatlock narrow 6

Medium weight fabric	Thread tension			
	Yellow	Green	Blue	Red
		0	4.5	7.5

#### • How to balance the thread tension

When the upper looper thread lies on the underside of the fabric;

- Turn the lower looper thread tension dial (red) to a higher number.

When the upper looper thread tension is too loose;



- Turn the upper looper thread tension dial (blue) toward a higher number.
- Turn the lower looper thread tension dial (red) toward a higher number.

When the needle thread tension is too loose;

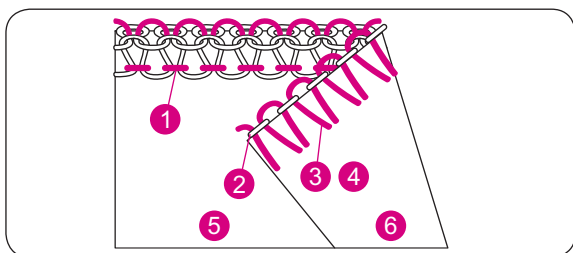
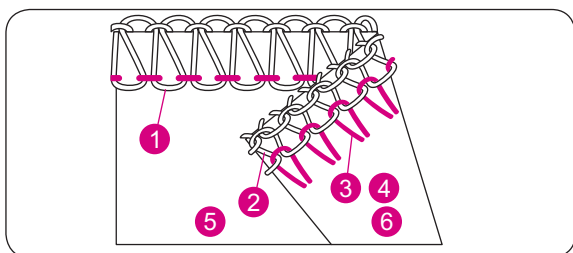
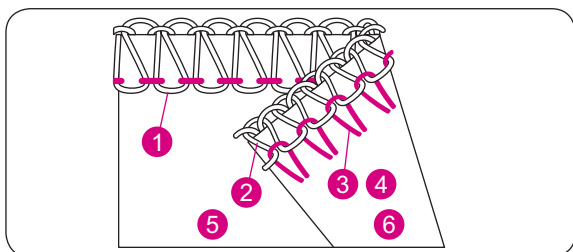
- Turn the needle thread tension dial (yellow or green) toward a higher number.
- Or, turn the upper looper thread tension dial (blue) toward a lower number.

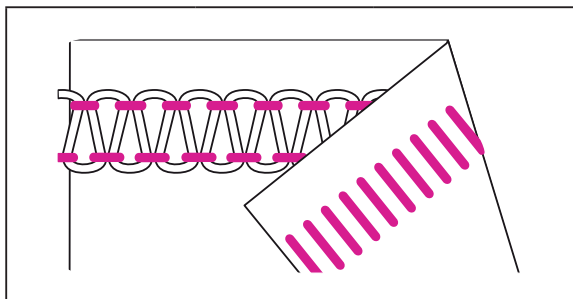



NP	 , 	Refer page 15
RHP	N	Refer page 14/15
SL	2.5–4	Refer page 27
ULC		Refer page 14

Thread Color Code refer page 19.

## 2–Thread Flatlock (11/12)

### PLEASE NOTE:

- These are suggested tension settings only.
- Tension settings are effected by;
  1. Type and thickness of fabric
  2. Needle size
  3. Size, type and fiber content of thread

### • Correct balance

- Set each tension dial to recommended setting and test sew on a sample of your fabric.

### 2–Thread Flatlock wide 11

Medium weight fabric	Thread tension			
	Yellow	Green	Blue	Red
	0			4.0

### 2–Thread Flatlock narrow 12

Medium weight fabric	Thread tension			
	Yellow	Green	Blue	Red
		0		4.5

### • How to balance the thread tension

When the lower looper thread tension is too tight or needle thread tension is too loose;

- Turn the lower looper thread tension dial (red) toward a lower number.
- Or, turn the needle thread tension dial (yellow or green) toward a higher number.

When the lower looper thread tension is too loose;

- Turn the lower looper thread tension dial (red) toward a higher number.

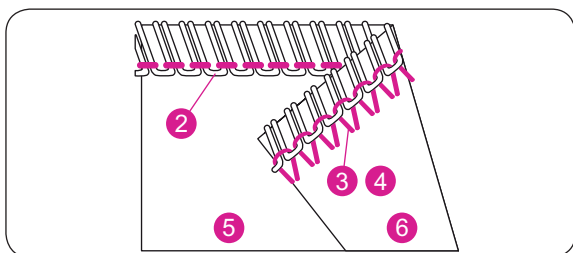
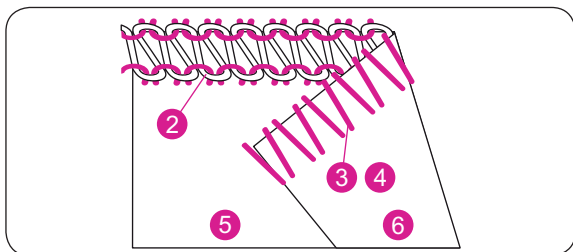



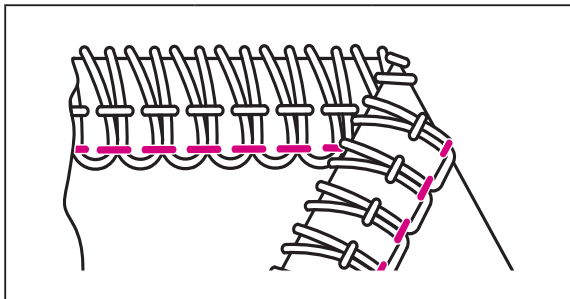

NP		Refer page 15
RHP	N	Refer page 14/15
SL	2.5–4	Refer page 27
ULC		Refer page 14

Thread Color Code refer page 19.

### 3–Thread Super Stretch (2)

#### PLEASE NOTE:

- These are suggested tension settings only.
- Tension settings are effected by;
  1. Type and thickness of fabric
  2. Needle size
  3. Size, type and fiber content of thread

#### • Correct balance

- Set each tension dial to recommended setting and test sew on a sample of your fabric.

#### 3–Thread Super Stretch 2

Medium weight fabric	Thread tension			
	Yellow	Green	Blue	Red
	4.0	4.0		3.5

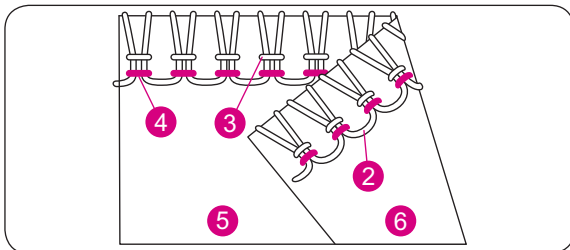

#### • How to balance the thread tension

When the lower looper thread tension is too loose;

- Turn the lower looper thread tension dial (red) toward a higher number.

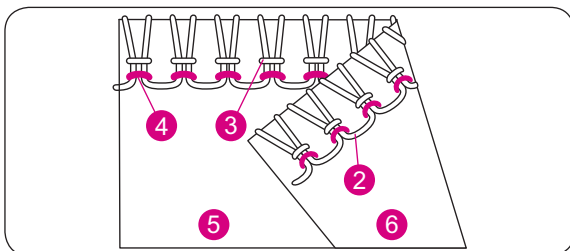

When the left needle thread tension is too loose;

- Turn the left needle thread tension dial (yellow) toward a higher number.

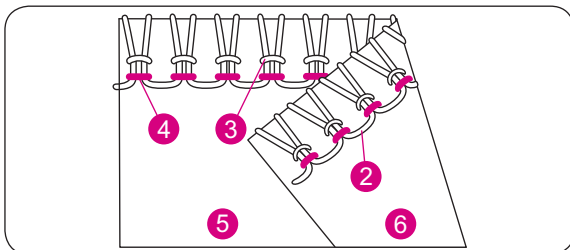

When the right needle thread tension is too loose;

- Turn the needle thread tension dial (green) toward a higher number.

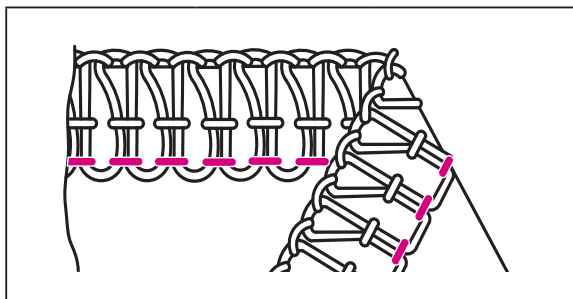

NP		Refer page 15
RHP	N	Refer page 14/15
SL	2.5–4	Refer page 27
ULC	-	Refer page 14

Thread Color Code refer page 19.

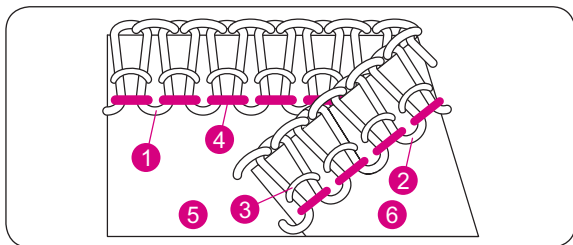
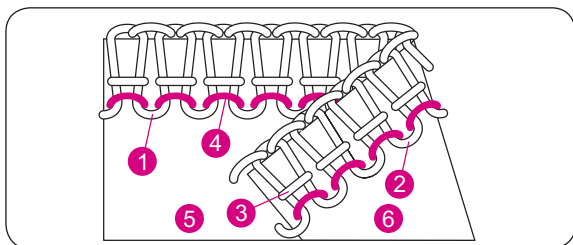
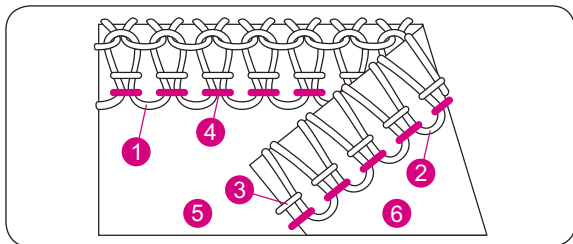
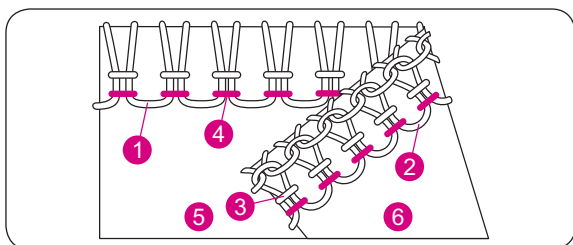

## 4-Thread Overlock with integrated safety seam (1)

### PLEASE NOTE:

- These are suggested tension settings only.
- Tension settings are effected by;
  1. Type and thickness of fabric
  2. Needle size
  3. Size, type and fiber content of thread

### • Correct balance

- Set each tension dial to recommended setting and test sew on a sample of your fabric.

### 4-Thread Overlock with integrated safety seam 1

Medium weight fabric	Thread tension			
	Yellow	Green	Blue	Red
	4.0	4.0	4.0	4.0

### • How to balance the thread tension

When the upper looper thread lies on the underside of the fabric;

- Turn the upper looper thread tension dial (blue) toward a higher number.
- Or, turn lower looper thread tension dial (red) to a lower number.

When the lower looper thread appears on the top of the fabric;

- Turn the lower looper thread tension dial (red) toward a higher number.
- Or, turn the upper looper thread tension dial (blue) toward a lower number

When the left needle thread tension is too loose;

- Turn the needle thread tension dial (yellow) toward a higher number.

When the right needle thread tension is too loose;

- Turn the right needle thread tension dial (green) toward a higher number.

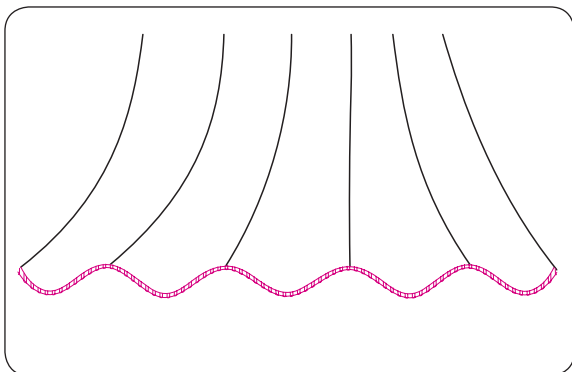

## HOW TO SEW A ROLLED HEM

- This machine can sew three types of rolled hems.
- Rolled hemming is done by rolling and overedging the fabric edge.
- Light weight fabrics such as lawn, voile, organdy, crepe, etc. perform the best.
- Rolled hemming is not suited for heavy or stiff fabrics.

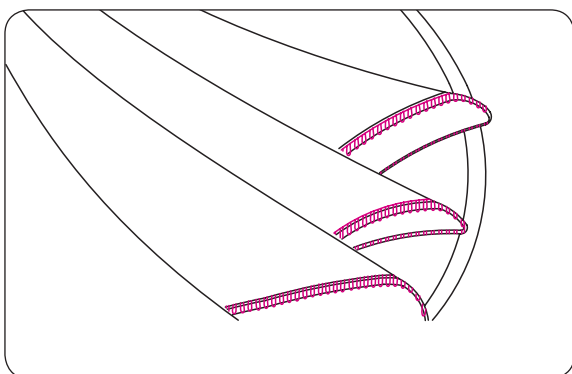

### PLEASE NOTE:

Rolled hemming can only be performed with the overlock right needle.

### PLEASE NOTE:

For a beautiful rolled hem thread the upper looper with wooly nylon and the needle and lower looper with lightweight regular thread.

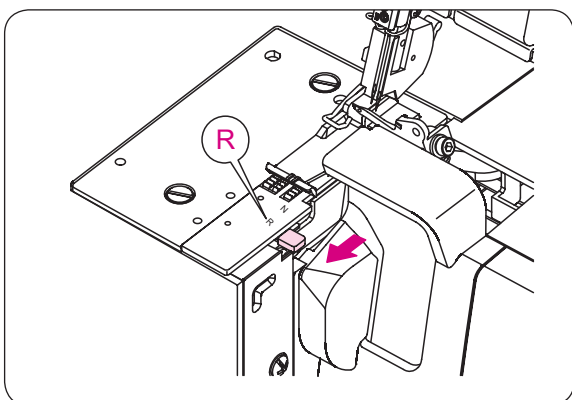

## Machine set up



### CAUTION:

Be sure to turn off power switch.

- Remove the overlock left needle.
- Move seam width finger knob to setting R.
- Set a cutting width between 5 and 6.
- Set stitch length dial to 1–2 and a fine seam will be sewn.

### Needle:

ELx705

### Thread:

A variety of thread combinations can be used for rolled hemming.

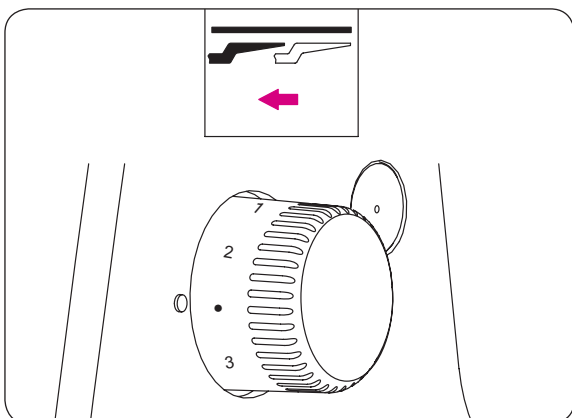

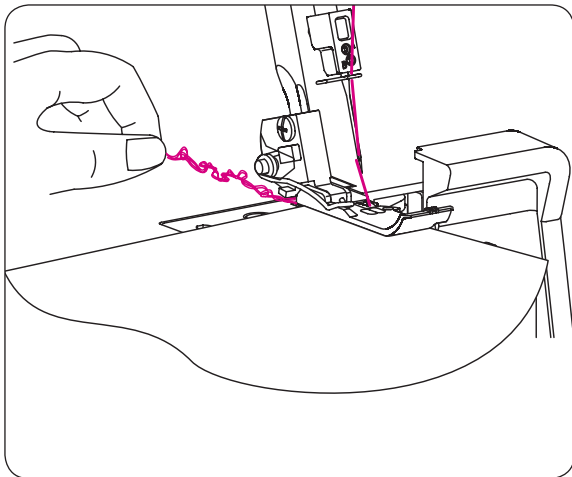

## Additional information about rolled hemming

- Hold the thread chain when you begin sewing to keep it from curling into the seam.
- Place a slight tension on the material in the sewing direction and a finer seam finish can be obtained.

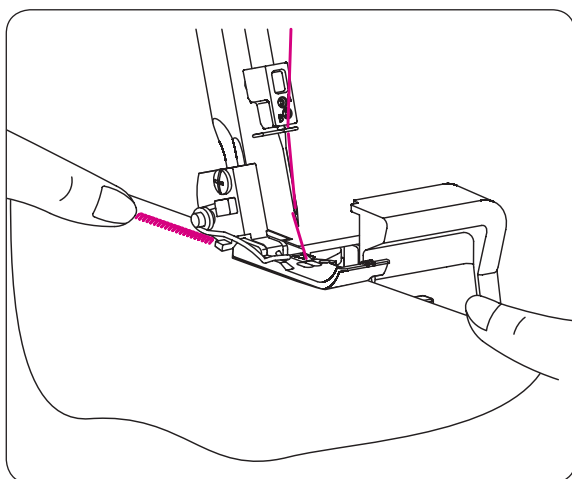

- The minimum overlock stitch width that can be obtained for rolled hemming is approximately 1/16" (1.5 mm) since the cutting width cannot be set below 9/64" (3.5 mm).

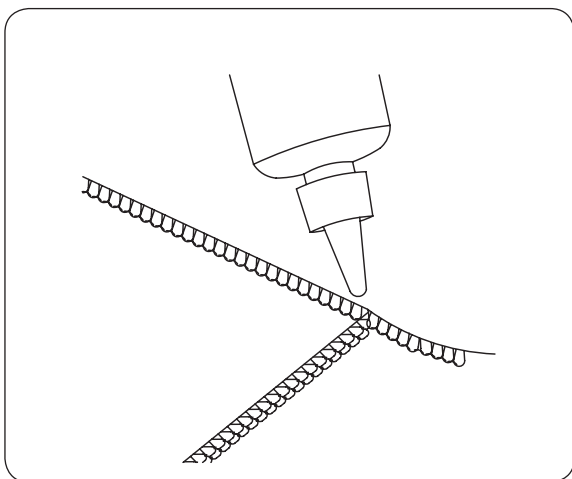

- **To secure the rolled hem thread chain**
  - Apply a small drop of liquid seam sealant to the end of the seam. Allow to dry, then cut the chain close to the stitches.

### PLEASE NOTE:

Test the liquid seam sealant for color fastness before use.

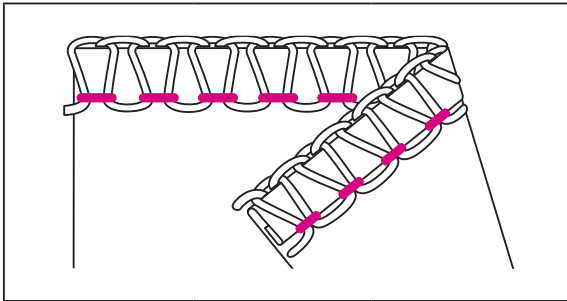

NP		Refer page 15
RHP	R	Refer page 14/15
SL	1-2	Refer page 27
ULC	-	Refer page 14

Thread Color Code refer page 19.

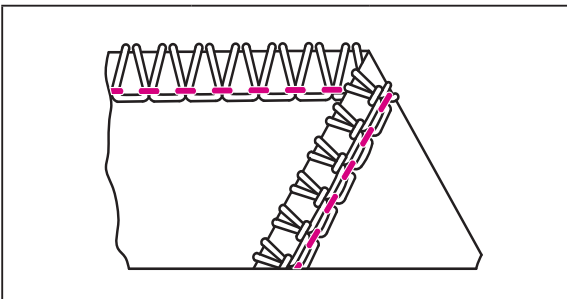
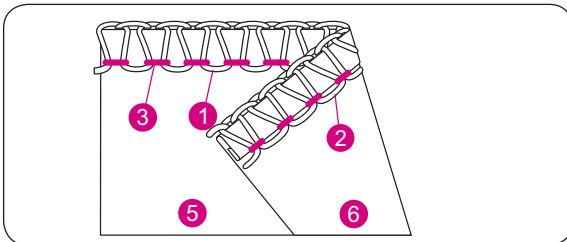

NP		Refer page 15
RHP	R	Refer page 14/15
SL	1-2	Refer page 27
ULC	-	Refer page 14

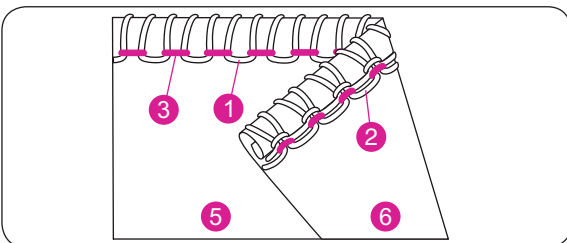

### 3-Thread Narrow Seam (7)

#### PLEASE NOTE:

For a beautiful narrow seam thread the upper and lower looper with wooly nylon and the needle with fine normal overlock thread.

#### • Correct balance

- Set each tension dial to recommended setting and test sew on a sample of your fabric

#### 3-Thread Narrow Seam 7

Light weight fabric	Thread tension			
	Yellow	Green	Blue	Red
Polyester		4.0	5.0	4.5
Woolly nylon		4.0	3.0	4.0

### 3-Thread Rolled Hem (8)

#### PLEASE NOTE:

For a beautiful rolled hem thread the upper looper with wooly nylon and the needle and lower looper with light weight regular thread.

#### • Correct balance

- Set each tension dial to recommended setting and test sew on a sample of your fabric

#### 3-Thread Rolled Hem 8

Light weight fabric	Thread tension			
	Yellow	Green	Blue	Red
Polyester		4.0	4.5	6.5
Woolly nylon		4.5	0	6.5

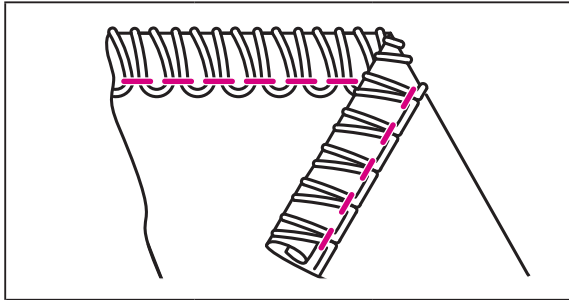

NP		Refer page 15
RHP	R	Refer page 14/15
SL	1-2	Refer page 27
ULC		Refer page 14

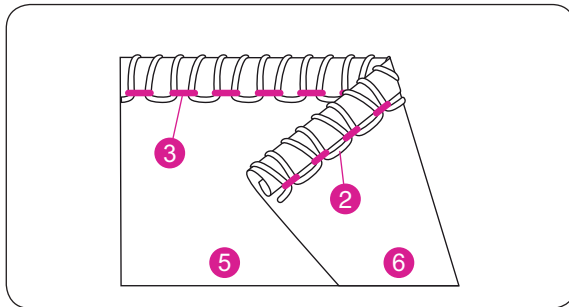

Thread Color Code refer page 19.

## 2-Thread Rolled Hem (13)

### PLEASE NOTE:

For a beautiful rolled hem thread the lower looper with wooly nylon and the needle with light weight regular thread.

### • Correct balance

- Set each tension dial to recommended setting and test sew on a sample of your fabric

### 2-Thread Rolled Hem 13

Light weight fabric	Thread tension			
	Yellow	Green	Blue	Red
Polyester		4.5		4.0
Woolly nylon		4.0		3.5

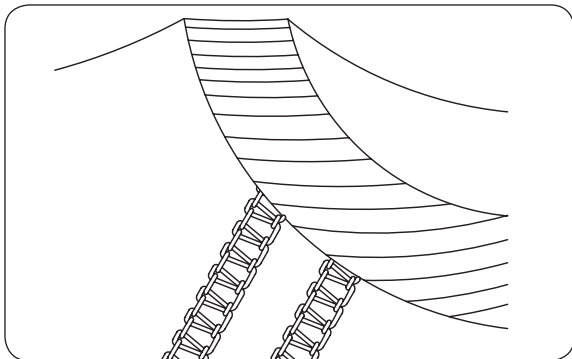

## STITCH VARIATIONS AND SEWING TECHNIQUES

### How To Sew a Flatlock Decorative Seam

A flatlock stitch is achieved by adjusting the tension of the 2-thread or 3-thread overlock stitch, sewing the seam, and then pulling the fabric apart to flatten the seam.

The flatlock stitch can be used as a construction and decorative stitch or for ornamentation only.

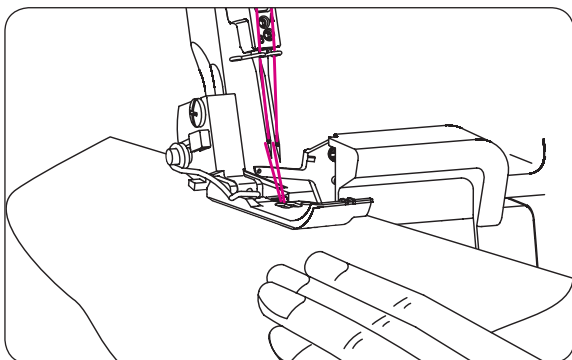

Thread Color Code refer page 19.

### Machine Set Up

- Use either overlock right needle or overlock left needle.
- Begin with the machine threaded and tension balanced for the 2-thread flatlock (page 36) or 3-thread flatlock stitch (page 35).

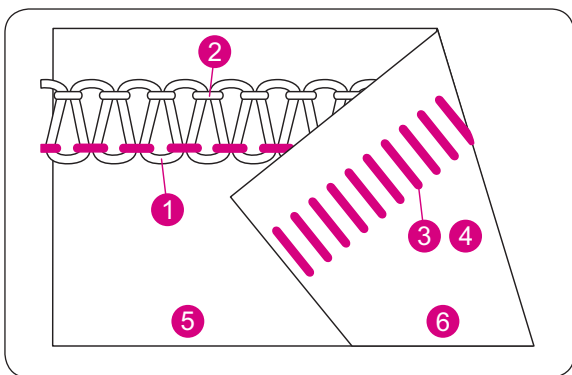

### Flatlocking a Seam

- Place the fabric wrong sides together to sew a decorative stitch on the right side of the garment.
- Sew the seam, trimming the excess fabric.
- The needle thread (yellow or green) will form a V on the underside of the fabric.
- In the 3-thread flatlock, the lower looper thread will form a straight line on the fabric edge. The upper looper thread will lie on top of the stitch.
- In the 2-thread flatlock, the lower looper thread will lie on top of the stitch.
- Pull on opposite sides of the seam to pull the stitches flat.

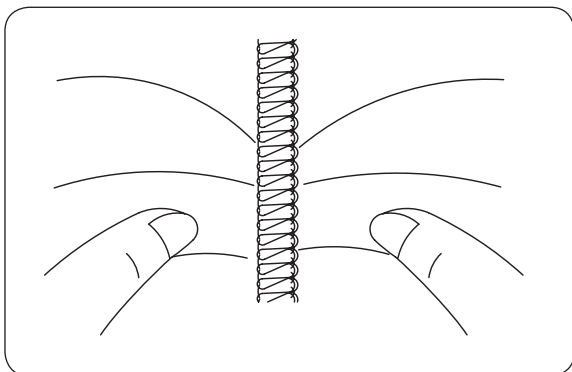

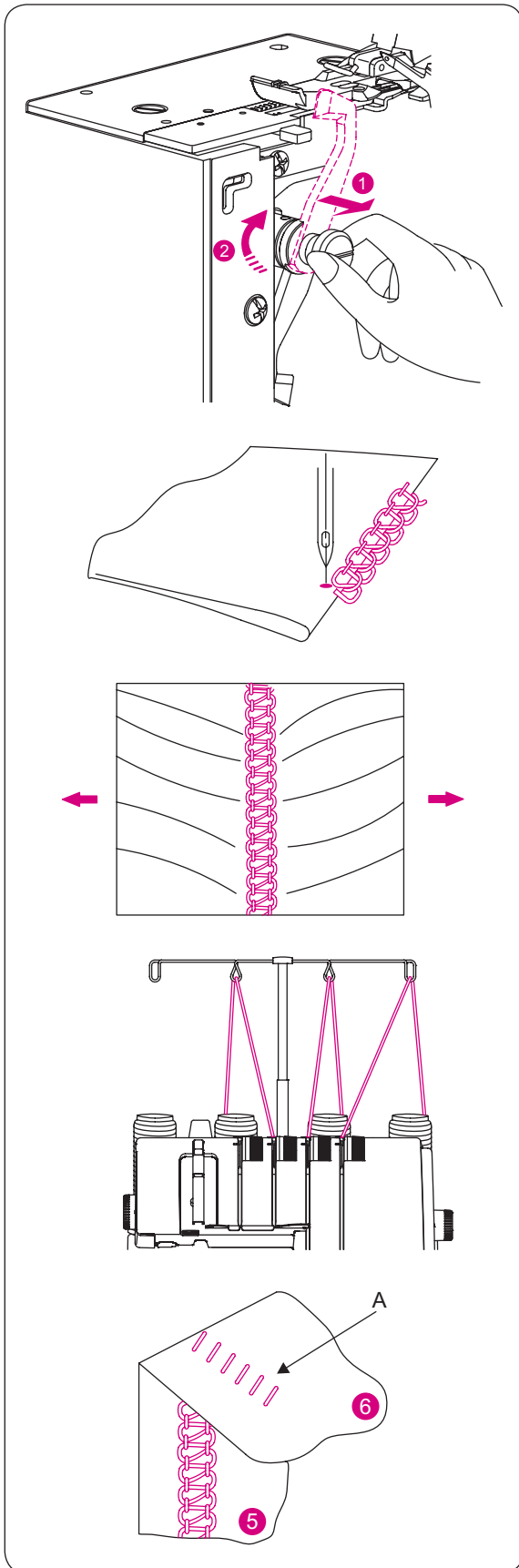

## Decorative Flatlocking

- Disengage the upper knife (page 13). The fabric is not trimmed on this stitch.

- Fold fabric wrong sides together.
- Position the fabric so the seam is sewn with part of the stitch extending off the fabric.

- Pull on opposite sides of the stitch to flatten

## Additional Information about Flatlocking

- The tensions must be correctly adjusted for the fabric to pull flat.
- The upper looper thread is the prominent thread in a 3-thread flatlock.
- The lower looper thread is the prominent thread in a 2-thread flatlock.
- Thread decorative yarn in the prominent threading path accordingly.

- For a ladder stitch, sew seam with right sides together.
- The needle thread will be the prominent thread that creates the ladder (A).



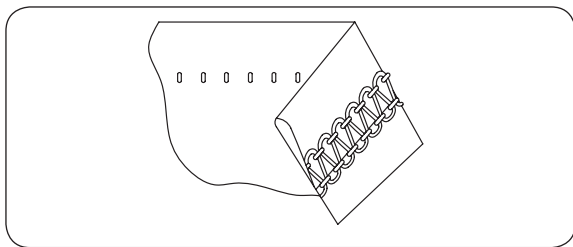

## How to sew an Overlock Blind Hem

The excess fabric is trimmed and the hem is sewn and the raw edges are overlocked in one operation.

The overlock blind hem is best suited for sewing knit wear. It provides a durable finish that is almost invisible.

Use overlock right needle and adjust machine for a narrow 3-thread overlock stitch. (Refer page 34)

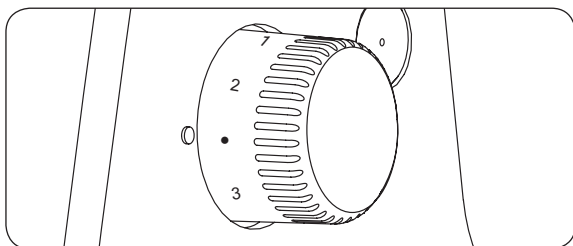

- Set the stitch length dial at 4.
- Fold the hem to the wrong side of the fabric, then back to the right side with 1/4" (6 mm) beyond the fold.
- Stitch on the extended hem edge, allowing the machine needle to barely catch the edge of the fold.

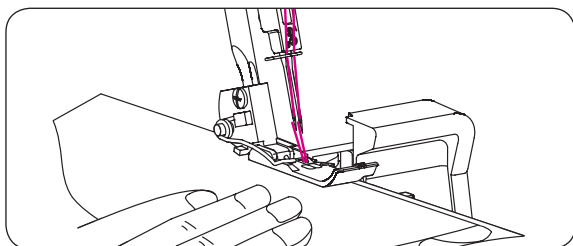

### PLEASE NOTE:

An optional blindstitch foot is available (Refer page 51).

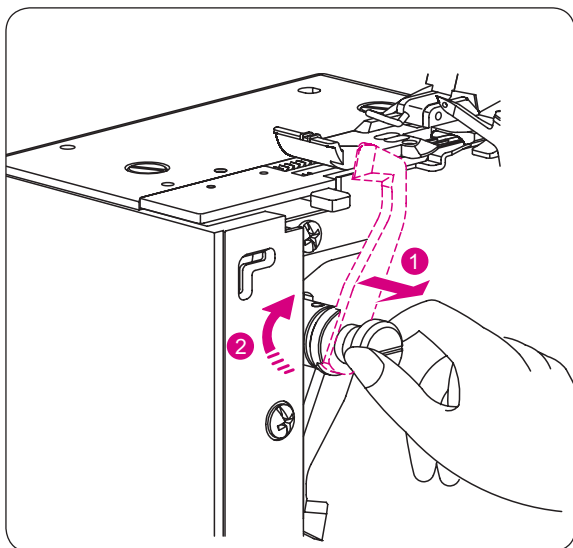

## How to sew Pin Tucks

- Sew decorative pin tucks on the fabric before cutting out the garment.
- Use overlock right needle and adjust machine for a narrow 3-thread overlock stitch. (Refer page 34)
- Place the movable upper knife in the nonworking position. (Refer page 13)
- Mark the fabric with the desired number of pin tucks using a water-soluble fabric marker.

### PLEASE NOTE:

For this technique also a 3-thread rolled hem or a 3-thread narrow seam can be used.

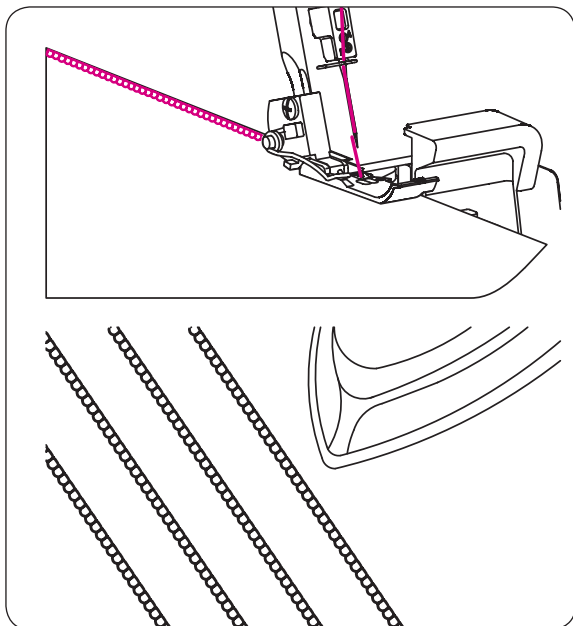

- Fold the fabric with the wrong sides together and sew.
  
- Press the pin tucks in the same direction.

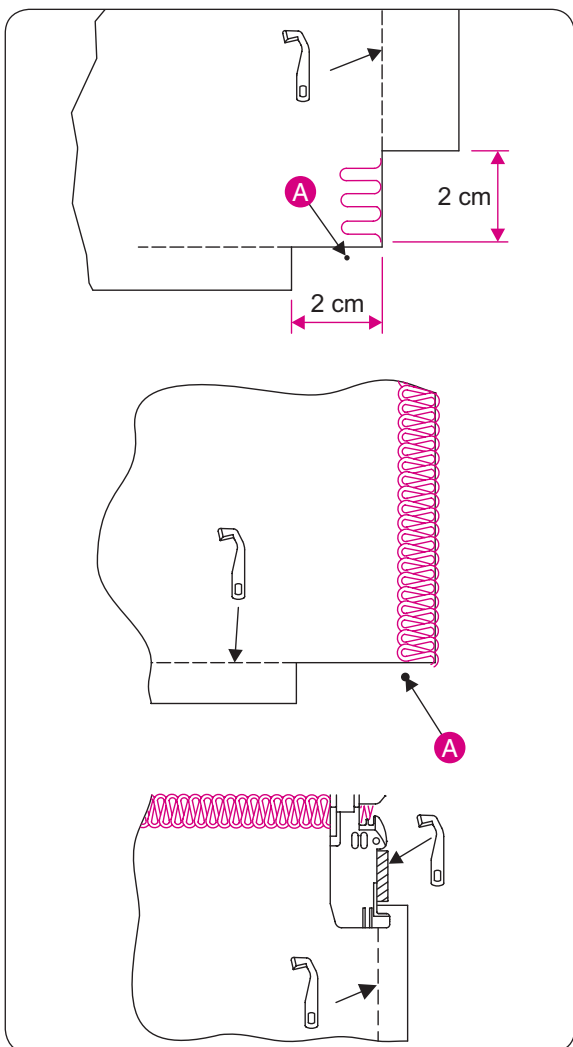

### How to turning Square Corners

- **Outside Corner**
  - Cut out approximately 2 cm (51/64") from the corner, in line with the overlock seam edge.
  
  - Sew one stitch beyond point (A) and stop.
  - Raise needle and presser foot.
  - Pull the fabric to the rear of the machine just enough to release the thread caught on the finger of the stitch plate.

**PLEASE NOTE:**  
Presser foot has been removed to show detail.

- Turn the fabric and lower the presser foot so that the upper knife is positioned in line with the cut edge.
- Pull slack threads up, then start to sew.

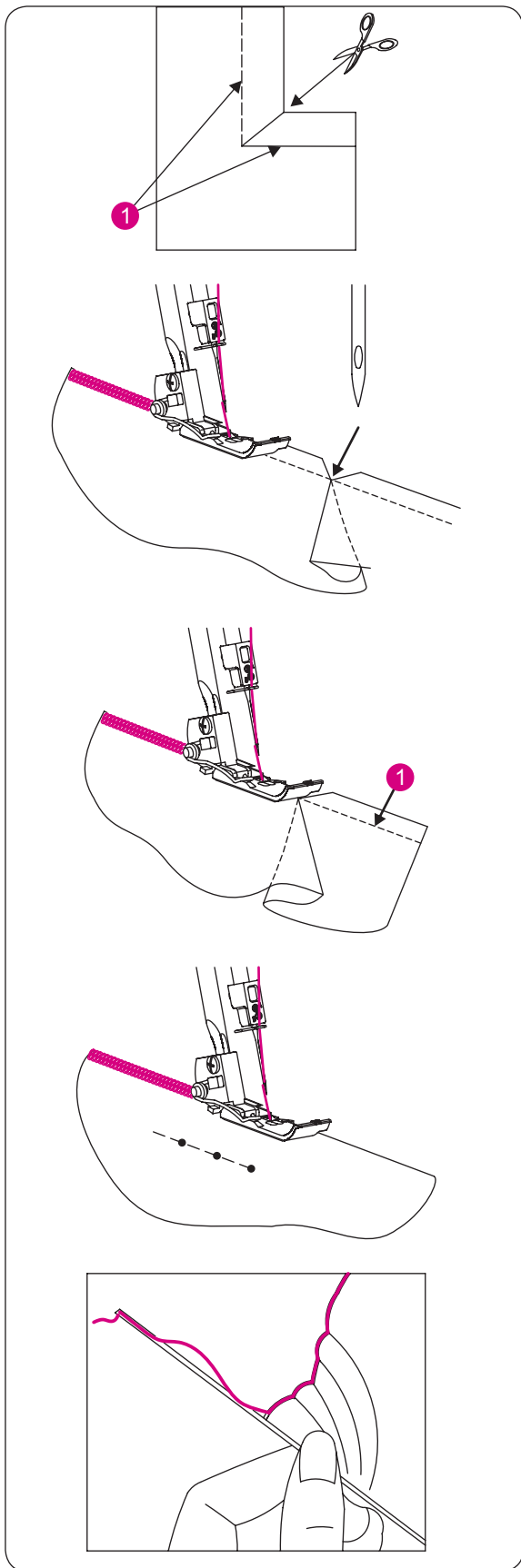

- **Inside Corner**

- Cut inside corner up to seam line (1) as shown.
- Sew along seam line.
- Sew up to end of fold. (Leave needle in fabric)

**PLEASE NOTE:**

Presser foot has been removed to show detail.

- Raise presser foot. (Leave needle in fabric)
- Spread fold and re-fold so that seam line is straight

- Turn the fabric and lower the presser foot so that the upper knife is positioned in line with the cut edge.
- Pull slack threads up, then start to sew.



**CAUTION:**

Sewing over pins will damage and /or destroy the cutting edge of the knives.

- **Pin Placement**

- Insert pins to the left of the presser foot. The pins will be easy to remove and are away from the cutting action of the knives.

- **Securing The Thread Chain**

- Thread a large eye, hand sewing needle (such as a tapestry needle) with the thread chain.
- Pull the thread chain into the overlock stitches or between two layers of fabric.

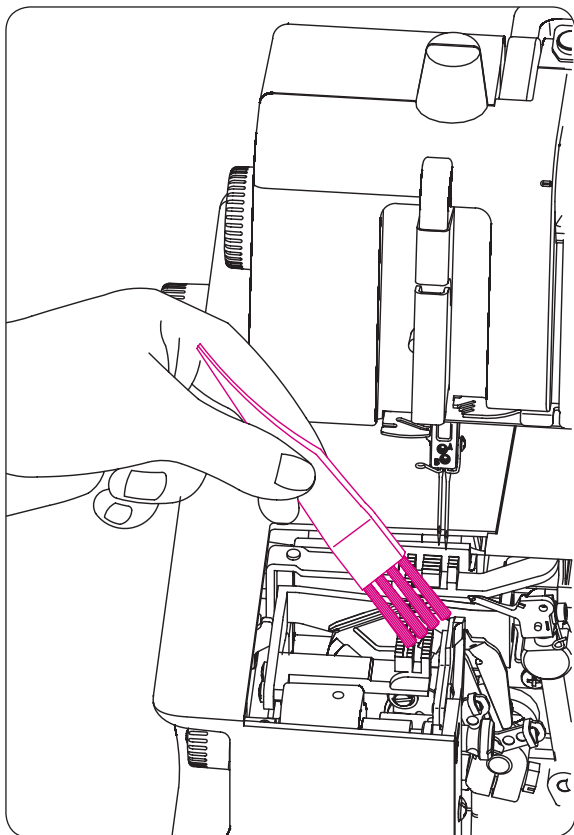

## MACHINE MAINTENANCE

An overlock machine requires more maintenance than a conventional machine for two reasons:

1. A lot of lint is produced due to the cutting action of the knives.
2. An overlock runs at a very high speed and needs to be oiled frequently to lubricate the internal working parts.

### Cleaning The Machine



#### CAUTION:

Before cleaning your machine, disconnect power line plug from the wall receptacle.

- Clean the lint from the looper and knife area often with a dry lint brush.

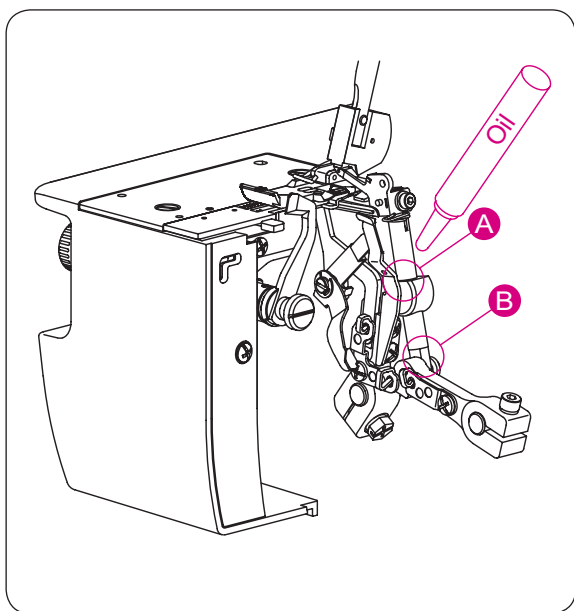

### Oiling The Machine



#### CAUTION:

Before lubricating your machine, disconnect power line plug from the wall receptacle.

- The oiling points shown in the diagram, should be oiled periodically.

#### PLEASE NOTE:

Use only sewing machine oil. Do not use any other oil or damage could result.

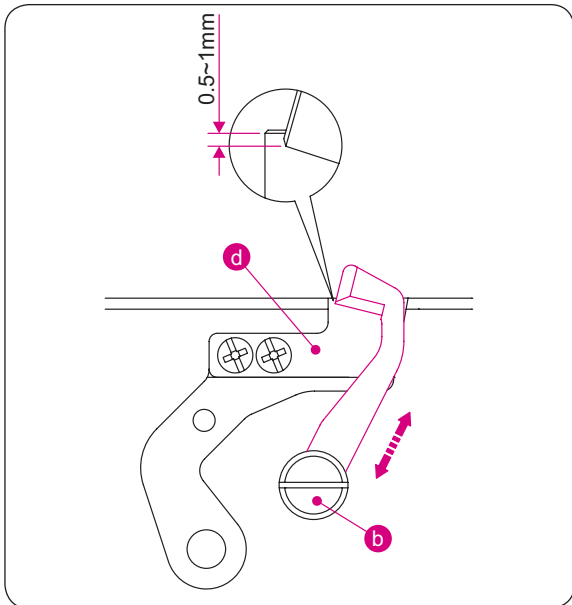
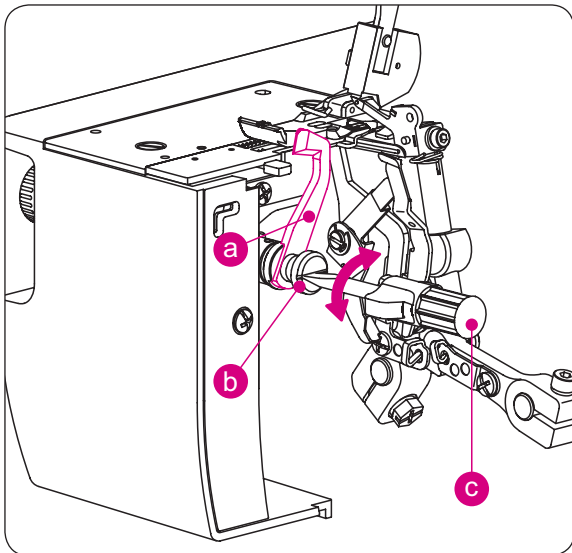

## Replace the Upper Knife



### CAUTION:

Before replacing the upper knife, disconnect power line plug from the wall receptacle.

- The upper knife should be changed when it becomes dull.
  - The upper knife can be replaced according to the directions provided, however if there are any difficulties experienced, consult your dealer representative to make the replacement.
  - Be sure that the power line plug is disconnected from the electric source.
- (a) Open the looper cover and set the upper knife in the working position.
  - (b) Loosen the upper knife set screw
  - (c) Remove the upper knife and turn the handwheel to lower the upper knife holder to its lowest position.
  - (d) In this position, put a new upper knife in the groove of the upper knife holder, making sure that the edge of the upper knife is approximately 0.5–1.0 mm below the surface of the fixed cutting blade.
  - (b) Tighten upper knife set screw.

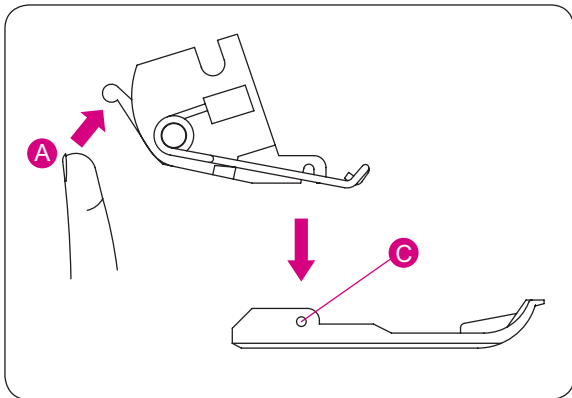

## OPTIONAL ACCESSORIES

The following optional presser feet specially prepared for this machine are available at extra-charge.

### PLEASE NOTE:

Do not use presser foot made for other machines. Use of such presser foot may result in interference with the needle and knife and can be hazardous.

The snap-on type presser foot of this machine permits easy removal and replacement.

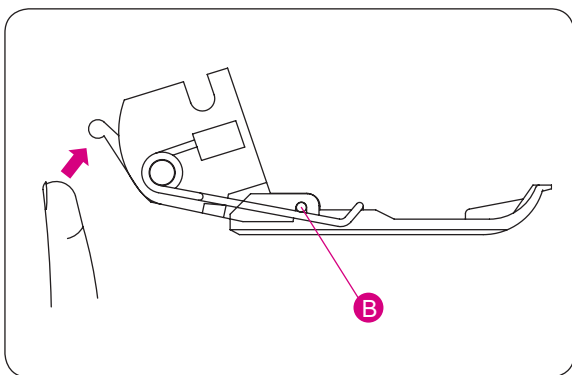

## Snap-On Type Presser Foot

### • Removal

- Turn the handwheel to raise the needles to the highest position.
- Raise the presser foot.
- Press red colored lever (A) located on back of clamp under the presser foot shank, raise presser foot shank to its High Lift position and while holding the presser foot shank in this position, remove the presser foot sole.

### • Replacement

- Place presser foot sole on stitch plate under presser foot shank so that hinge pin (C) will fit in slot (B) of the shank. Then lower presser foot shank.
- If presser foot sole can not be placed under presser foot shank easily, raise presser foot shank to its High Lift position and while holding it in this position, place presser foot sole under presser foot shank. Then lower presser foot shank.
- Raise presser foot shank and make sure the presser foot sole is properly attached to the presser foot shank.

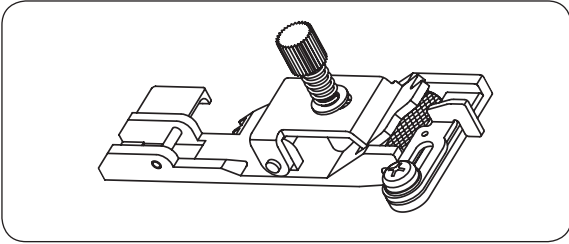

## Optional Presser Feet

- **Elasticator Foot**

- This foot is used for attaching elastic tape to the garment and the amount of contraction of the elastic tape can be adjusted as required.

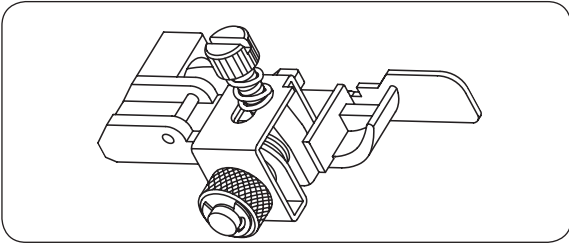

- **Blind stitch Foot**

- This foot is ideal for sewing blindstitch and blindhem.

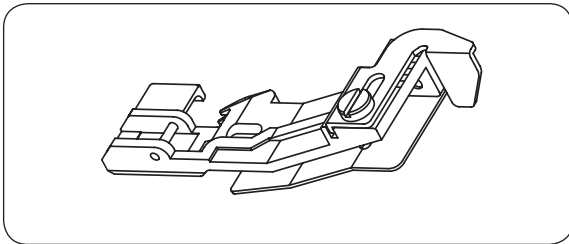

- **Gathering Foot**

- This foot is most suited for gathering when sewing tiered skirts, yokes, cuffs and frills on skirts, etc.
- This foot is also suited for sewing two fabrics together and gathering the bottom fabric in one operation.

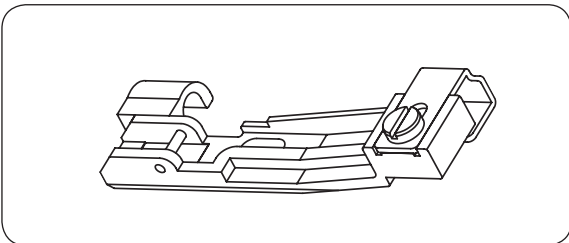

- **Beading/Sequins Foot**

- This foot is used for sewing on strands of beads and pearls.

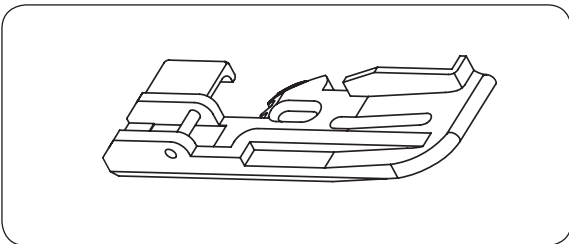

- **Piping Foot**

- This foot is ideal to produce and sew in piping.

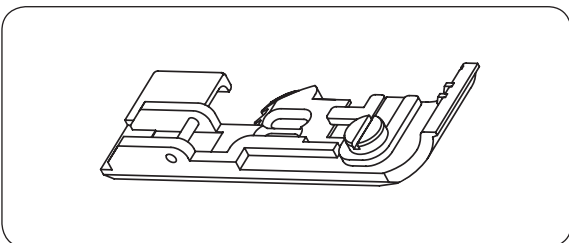

- **Ribbon-couching Foot**

- This sewing foot is suited for sewing on tapes, etc.

# TROUBLESHOOTING

Condition	Cause	Remedy Page
<b>Fabric does not feed well.</b>	1. Lengthen stitch length.	27
	2. Increase presser foot pressure for heavy weight fabric.	28
	3. Decrease presser foot pressure for light weight fabric.	28
<b>Needle breaks.</b>	1. Insert needle correctly.	16
	2. Do not pull fabric while sewing.	31
	3. Tighten needle set screw.	16
	4. Use a larger needle on heavy fabrics.	16
<b>Thread breaks.</b>	1. Check threading.	19–25
	2. Check for tangled or caught thread.	26
	3. Insert needle correctly.	16
	4. Insert new needle, current needle may be bent or have a blunt point.	9
	5. Use only high quality thread.	53
	6. Loosen thread tension.	31–38
<b>Stitch skip.</b>	1. Insert new needles, current needles may be bent or have a blunt point. Use only ELx705 overlock needles.	9
	2. Tighten needle set screw.	16
	3. Insert needles correctly.	16
	4. Change type or size of needles.	16
	5. Check threading.	19–25
	6. Increase presser foot pressure.	28
	7. Use a high quality thread.	53
<b>Irregular stitches.</b>	1. Balance thread tension.	31–38
	2. Check for tangled or caught thread.	26
	3. Check threading.	19–25
<b>Fabric puckers.</b>	1. Loosen thread tension.	31–38
	2. Check for tangled or caught thread.	26
	3. Use high quality light weight thread.	53
	4. Shorten stitch length.	27
	5. Decrease presser foot pressure for light weight fabrics.	28
<b>Irregular trimming.</b>	1. Check alignment of knives.	49
	2. Replace one or both knives.	49
<b>Fabric jams.</b>	1. Close looper cover before sewing.	10
	2. Check for tangled or caught thread.	26
	3. Compress thick layers of fabric with conventional machine before sewing with overlock.	
<b>Machine does not operate.</b>	1. Connect machine to power source and switch it on.	10
	2. Close the looper cover.	



## FABRIC, THREAD AND NEEDLE CHART

Woven			
Fabric		Thread	Needle ELx705
Light weight	Lawn	Cotton: #100	#80/12
	Organdy	Silk/ Rayon: #100	
	Voile	Spun: #80 – #90	
	Crepe	Polyester: #80 – #100	
Medium weight	Muslin	Cotton: #60 – #80	#90/14, #80/12
	Seersucker	Silk/ Rayon: #50	
	Satin	Spun: #60 – #80	
	Gabardine	Polyester: #60 – #80	
	Broadcloth		
Heavy weight	Oxford	Cotton: #40 – #60	#90/14
	Denim	Silk/ Rayon: #40 – #60	
	Tweed	Spun: #60 – #80	
	Serge	Polyester: #50 – #80	
	Corduroy		

Knit			
Fabric		Thread	Needle ELx705
Light weight	Tricot	Spun: #80 – #90	#80/12
		Polyester: #60 – #80	
Medium weight	Jersey	Spun: #60 – #80	#90/14, #80/12
		Polyester: #60 – #80	
		Cotton: #60 – #80	
Heavy weight	Wool (woven, knit)	Spun: #60 – #80	#90/14, #80/12
		Polyester: #50 – #60	
		Woolly nylon	
		Woolly Polyester	

# SPECIFICATION

## Technical Summary

Stitch Formations	15 stitches 1–2 needles 2 loopers	
Needle system	ELx705	
Cutting width	5–7 mm from the left needle 3–5 mm from the right needle	
Stitch length	1–4 mm (standard: rolled hemming 1–2, standard: overlock 2.5)	
Differential feed	stretching 1–0.6 gathering 1–2	
Presser foot lift	4.5 mm	
Sewing light	LED	
Sewing speed	1300 stitches/minutes.	
Foot control	Type 4C–316B for (USA/Canada)	Type 4C–316C / 4C–326C / 4C–326G / 4C–345G for other countries
Dimensions (L x B x H) mm	336 x 263 x 294	
Weight (kg)	7.2 kg	



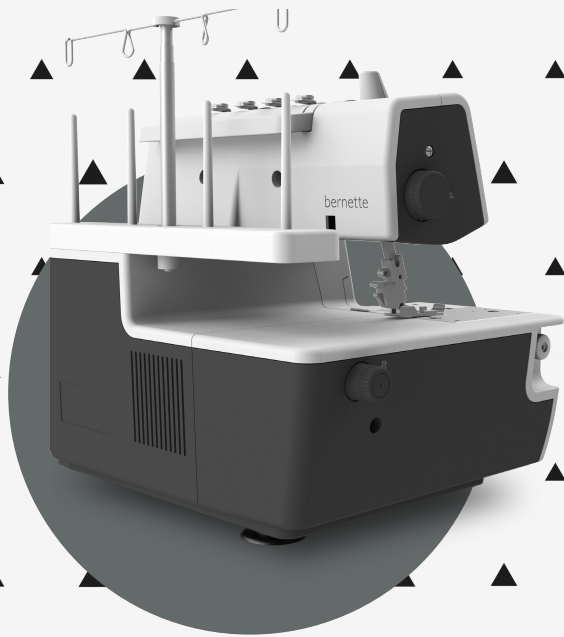

[www.mybernette.com/yellow-shirt](http://www.mybernette.com/yellow-shirt)

EN - 02/2017 - 3rd Edition  
5040005.0.04 / G8P01  
© BERNINA International AG  
Steckborn CH, [www.bernina.com](http://www.bernina.com)