



**THE
INTERTWINE**
**Regional Trails
Signage Guidelines**

June 20, 2012
Signage Guidelines

About Metro

Clean air and clean water do not stop at city limits or county lines. Neither does the need for jobs, a thriving economy, and sustainable transportation and living choices for people and businesses in the region. Voters have asked Metro to help with the challenges and opportunities that affect the 25 cities and three counties in the Portland metropolitan area.

A regional approach simply makes sense when it comes to providing services, operation venues and making decisions about how the region grows. Metro works with communities to support a resilient economy, keep nature close by and respond to a changing climate. Together we're making a great place, now and for generations to come.

Stay in touch with news, stories and things to do.
www.oregonmetro.gov/connect

Metro Council President:

Tom Hughes

Metro Councilors:

Shirley Craddick, District 1

Carlotta Collette, District 2

Carl Hosticka, District 3

Kathryn Harrington, District 4

Rex Burkholder, District 5

Barbara Roberts, District 6

Auditor:

Suzanne Flynn

THE INTERTWINE

Regional Trails Signage Guidelines

Prepared for:
Metro Sustainability Center
600 NE Grand Ave.
Portland, OR 97232-2736
T 503.797.1700
www.oregonmetro.gov

Mayer/Reed

319 SW Washington Street
Suite 820
Portland, Oregon 97204
T 503.223.5953
www.mayerreed.com

Metro:

Robert Spurlock, *Regional Trails Planner*

Tim Richard, *Principal Regional Planner*

Mary Anne Cassin,
Parks Planning & Development Manager

Advisory Committee Stakeholders:

Tammy Abbot, *State Parks Sign Coordinator*
Oregon Parks & Recreation Dept.

Jean Akers, *Planner*
Vancouver-Clark Parks & Recreation

Kris Schamp
Northwest Trail Alliance

Katherine Kelly, *Transportation Planning Manager*
City of Gresham

Laurie DeVos, *Landscape Architect*
City of Hillsboro Parks & Recreation

Bruce Barbarasch, *Natural Resources Manager*
Tualatin Hills Parks & Recreation

Sarah Coates-Huggins, *Planner*
Portland Parks & Recreation

Katie Dunham & Michelle Healy
North Clackamas Parks & Recreation

Anthony Buztek, *Transportation Engineer*
Metro

Shelly Oylear, *Bike & Pedestrian Coordinator*
Washington County

Basil Christopher, *Bike & Pedestrian Coordinator*
Oregon Department of Transportation - Region 1

Joe Marek, *Transportation Engineer*
Clackamas County

Roger Geller & Denver Igarta
Portland Bureau of Transportation

Greg Stout & Jeff Peck
City of Tigard

.....

Table of Contents

Section 1: Introduction

- 1.02** Forward
- 1.03** How to use these Guidelines
- 1.04** Process Flow Chart for Signing a Regional Trail
- 1.05** FAQs

Section 2: Sign Family

- 2.02** Off-Street Trail Signs
- 2.04** On-Street Connection Signs
- 2.05** The Intertwine Logo Components

Section 3: Sign Location and Planning

- 3.02** Trail Scenario 1: Trail Connections
- 3.04** Trail Scenario 2: Trail Intersections
- 3.06** Trail Scenario 3: Trail Spurs
- 3.08** Application of The Intertwine Logo to Existing Signs

Section 4: Fabrication Details

- 4.02** Sign Panel Fabrication: Option 1
- 4.03** Sign Panel Fabrication: Option 2
- 4.04** Sign Panel Fabrication: Option 3
- 4.05** Typical Sign Placement & Mounting Hardware
- 4.07** Sign Type A: Trailhead Sign Overview
- 4.11** Sign Type B: Trail Access Sign Overview
- 4.17** Sign Type C: Off-Street Pedestrian Directional Sign Overview
- 4.23** Sign Type D: Off-Street Multi-Use Directional Sign Overview
- 4.29** Sign Type E: Mile Marker Sign Overview
- 4.33** Sign Type F: On-Street Pedestrian Directional Sign Overview
- 4.39** Sign Type G: On-Street Bicycle Directional Sign Overview
- 4.43** Sign Type H: Intertwine Logo Components Overview
- 4.48** Symbols
- 4.50** Trail Map
- 4.51** Typography
- 4.52** Colors
- 4.53** Logos

Section 5: Appendix

- 5.02** Regional Trails Map
- 5.03** Regional Trails List
- 5.04** Definitions
- 5.05** Jurisdictional Signage Documents

Forward

This manual serves as a technical resource to guide parks and transportation agencies as they plan, design, and fabricate wayfinding signage along regional trails in the Portland-Vancouver metropolitan area. Metro and its partners developed the manual in response to requests from the public for better uniformity and consistency of signage along regional trails. Additional impetus came with the advent of The Intertwine brand and the opportunity to give the regional trail system a unifying identity.

The guidelines are intended to be followed when signing off-street regional trails and on-street bicycle and pedestrian facilities that serve as the primary routes connecting one trail segment to the next. The manual gives guidance for sign placement, messaging and content, color, size, and font. It should be used when signing new trails for the first time or when replacing or retrofitting signs along existing trails.

Since it is primarily local parks and transportation agencies that will implement the signs, Metro and its partners felt that guidelines were more appropriate than standards. The guidelines are designed to offer flexibility to agencies that already have trail sign standards in place while also providing solutions for certain conditions where existing standards may fall short. For example, these guidelines embrace the increasing ubiquity and popularity of Oregon's standard green bicycle directional sign and recommends its use along on-street bicycle connections, while acknowledging that the sign is not ideal for use along off-street trails since it is not intended for pedestrians and does not generate intrigue about The Intertwine.

With these guidelines, parks and transportation agencies can provide regional trail users an attractive, consistent sign system.

The Intertwine Park Providers:

City of Battle Ground	Oregon Parks & Recreation Dept.
City of Camas	Portland Parks & Recreation
City of Cornelius	City of Ridgefield
City of Durham	City of Sherwood
City of Fairview	City of Tigard
City of Forest Grove	City of Troutdale
Forest Park Conservancy	City of Tualatin
City of Gladstone	Tualatin Hills Parks & Recreation District
City of Gresham	Vancouver-Clark Parks & Recreation
City of Hillsboro Parks & Recreation	Washington County
Lake Oswego Parks & Recreation	City of Washougal
Metro	City of West Linn Parks & Recreation
North Clackamas Parks & Recreation Dept.	City of Wilsonville
Oregon City Parks & Recreation Dept.	City of Wood Village

How to use these Guidelines

This document is organized into sections that relate to sign types, information content, function and location planning. These are described below in a brief overview.

Section 1: Introduction

This section provides background information for understanding the intent and purpose of the Regional Trail Network, how to use the guidelines and frequently asked questions.

Section 2: Sign Family Overview

This section provides a detailed description and illustration of each sign type showing content and message variations for pedestrian-only and multi-use trails, roadway connections and Intertwine identity.

Section 3: Sign Location Planning

This section provides illustrated examples of various trail and roadway connection scenarios as a guide for sign location planning and selection of appropriate sign types and sign message.

The examples provided in these guidelines should not be taken as an exhaustive list of every possible scenario. The intention is to provide enough guidance for a planner or designer to create consistent solutions for any scenario they may encounter.

Section 4: Fabrication

This section provides detailed information and dimensioned drawings for the fabrication of each sign type including materials, colors, sizes, message layouts and imaging techniques. The fabrication details create a standard for sign appearance throughout the regional trails network based on commonly available materials and processes. Sign post options are included to accommodate various jurisdictional requirements and preferences, however, specifications for the installation of sign posts will vary by jurisdiction and therefore are not provided in this document.

1.04
Introduction

Process Flow Chart

Process Flow Chart for Signing a Regional Trail

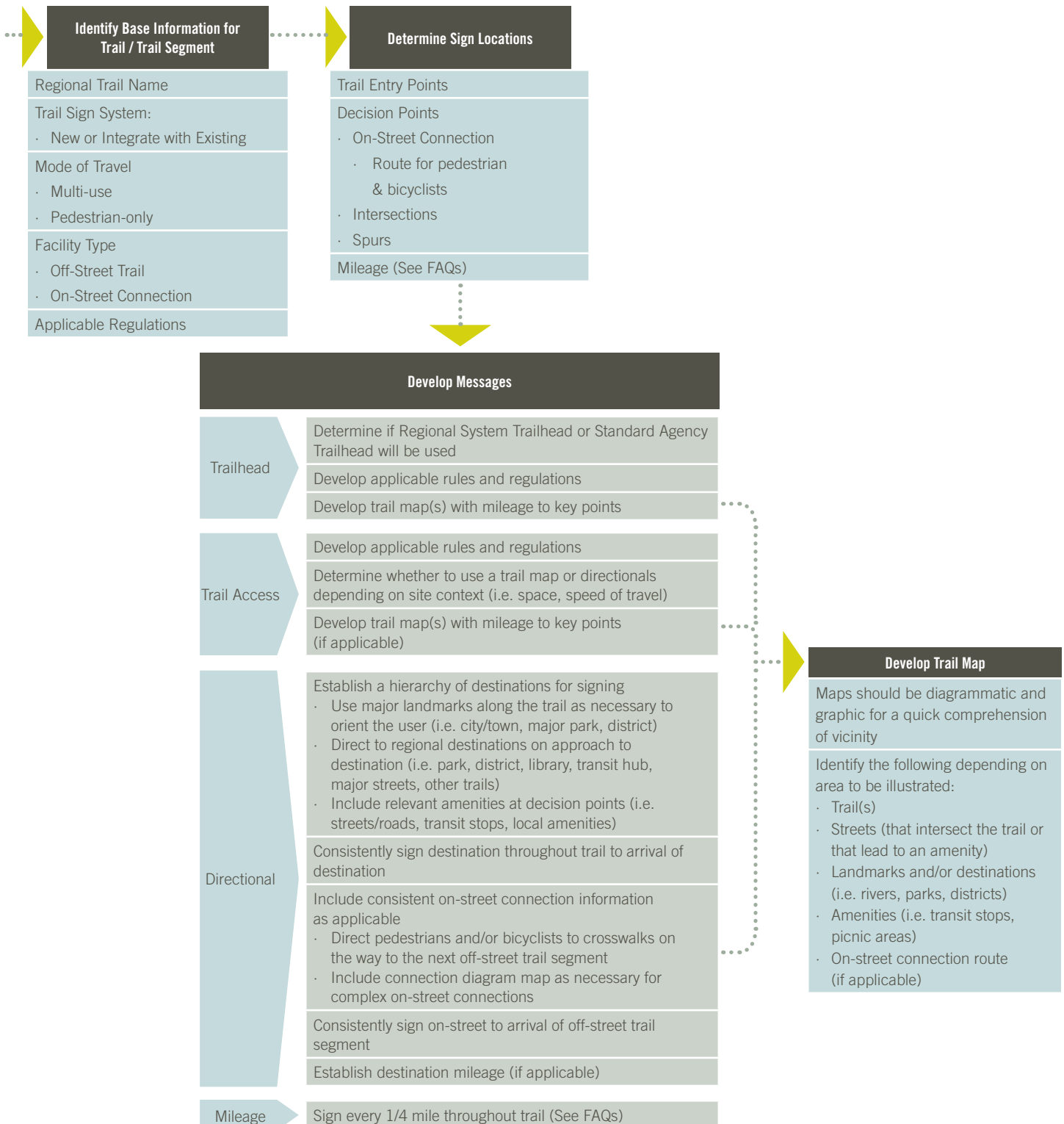

FAQs

What do I use if my regional trail already has signage?

While some regional trails currently maintain signage from an adopted Sign Manual, these guidelines provide sign types that can be integrated into existing sign systems. In Section 3, the methodology for sign placement and content can be used by a jurisdiction with existing signage to add to their system as necessary.

How should I determine mileage for my regional trail?

Check with Metro to determine the "zero point" or benchmark for each trail's mileage numbering system. For riparian trails, the general rule is to use river miles, with zero located at the mouth of the stream. Non-riparian trails should be numbered south to north and west to east, modeled after the Interstate Highway System. The Wildwood Trail's mile markers are south to north as well.

We are already using ODOT's standard bicycle signs on our off-street multi-use trail, why should we use signage from these Guidelines?

Because of the popularity of Portland's Bicycle Signage, which have been adopted by ODOT (sign number OBD1-3), some agencies in the region have implemented these signs along off-street multi-use trails. While that signage is highly effective, it is designed primarily for bicyclists traveling at an average roadway speed. Borrowing from that system, these guidelines accommodate both bicyclist and pedestrian trail users. The width of the off-street signs has been reduced for use primarily along narrower off-street trails allowing the mounting height to be lower.

I need a sign that isn't in these Guidelines. How do I resolve that?

The examples provided in these guidelines should not be taken as an exhaustive list of every possible scenario. The intention is to provide enough guidance for a planner or designer to create consistent solutions for any scenario they may encounter. Strive for consistency and clarity.

Can I use abbreviations when signing my regional trail?

Follow the guidance on abbreviations found in Section 1A.15 of the 2009 MUTCD.

Will these Guidelines be updated?

Yes. Metro considers this a "living" document. If your experience designing and installing signs from this document generates new information about what works and what doesn't work, please provide that information to Metro for consideration in future updates.

What is The Intertwine?

The Intertwine is the Portland metropolitan region's network of parks, trails and natural areas. More information about The Intertwine is available at www.theintertwine.org.

.....

Section 2: Sign Family

- 2.02** Off-Street Trail Signs
- 2.04** On-Street Connection Signs
- 2.05** The Intertwine Logo Components

2.02
Sign Family

Off-Street Trail Signs

Off-Street Trail Signs

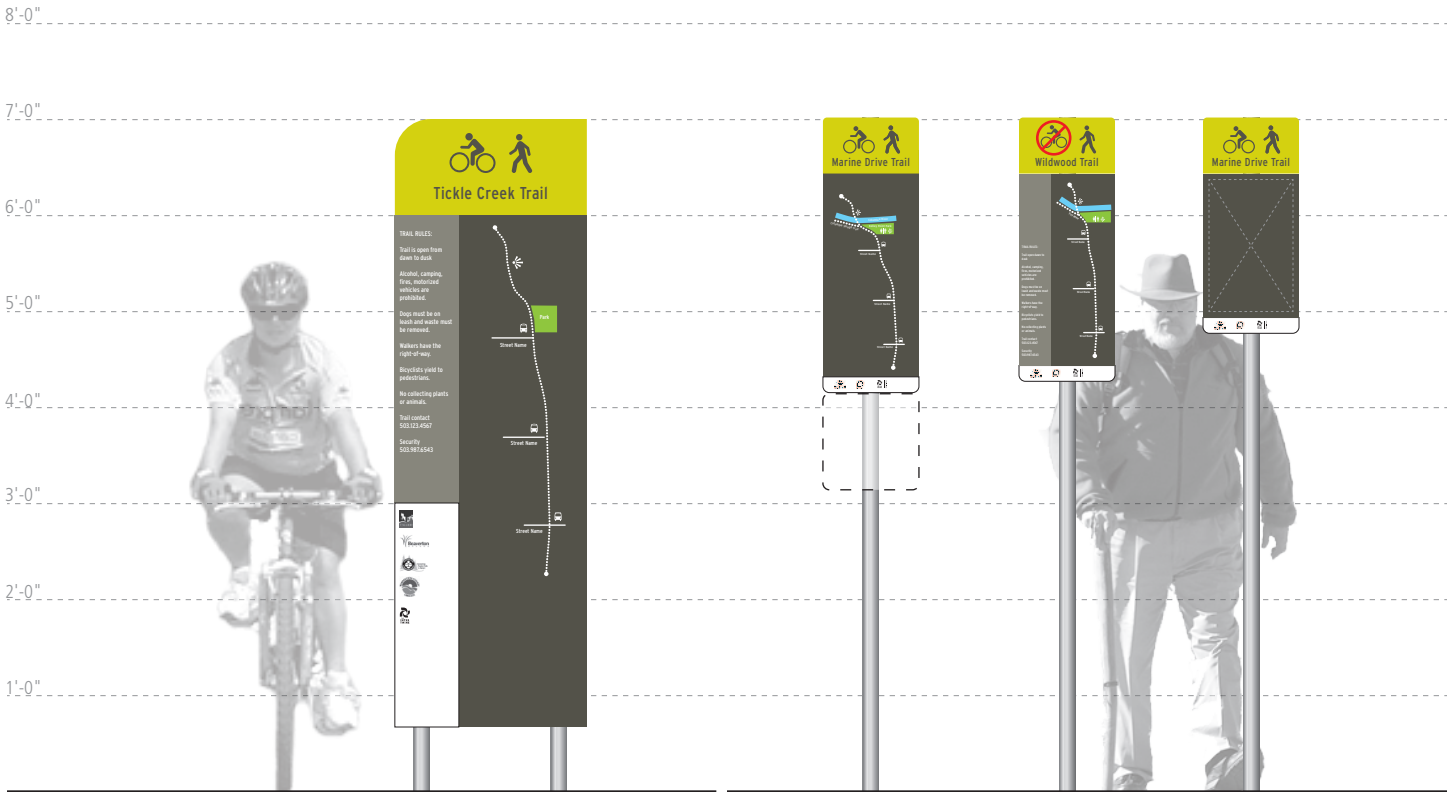

SIGN TYPE A: Trailhead

Trailhead Signs are located at major trail access points which are distinguished by vehicle parking, restrooms, staging areas or other features. This sign type includes a map of the entire trail and the surrounding amenities as well as provides space for jurisdiction/partner logos and trail regulations. This sign type is compatible with The Intertwine Branding Signage.

Layouts on page 4.07
Trail map guidelines on page 4.50

SIGN TYPE B: Trail Access

Trail Access signs are located at trail access points where the trail typically meets the street right of way. This sign type identifies the trail and mode of travel and may include a trail map, directions or other information.

Layouts on page 4.11
Trail map guidelines on page 4.50

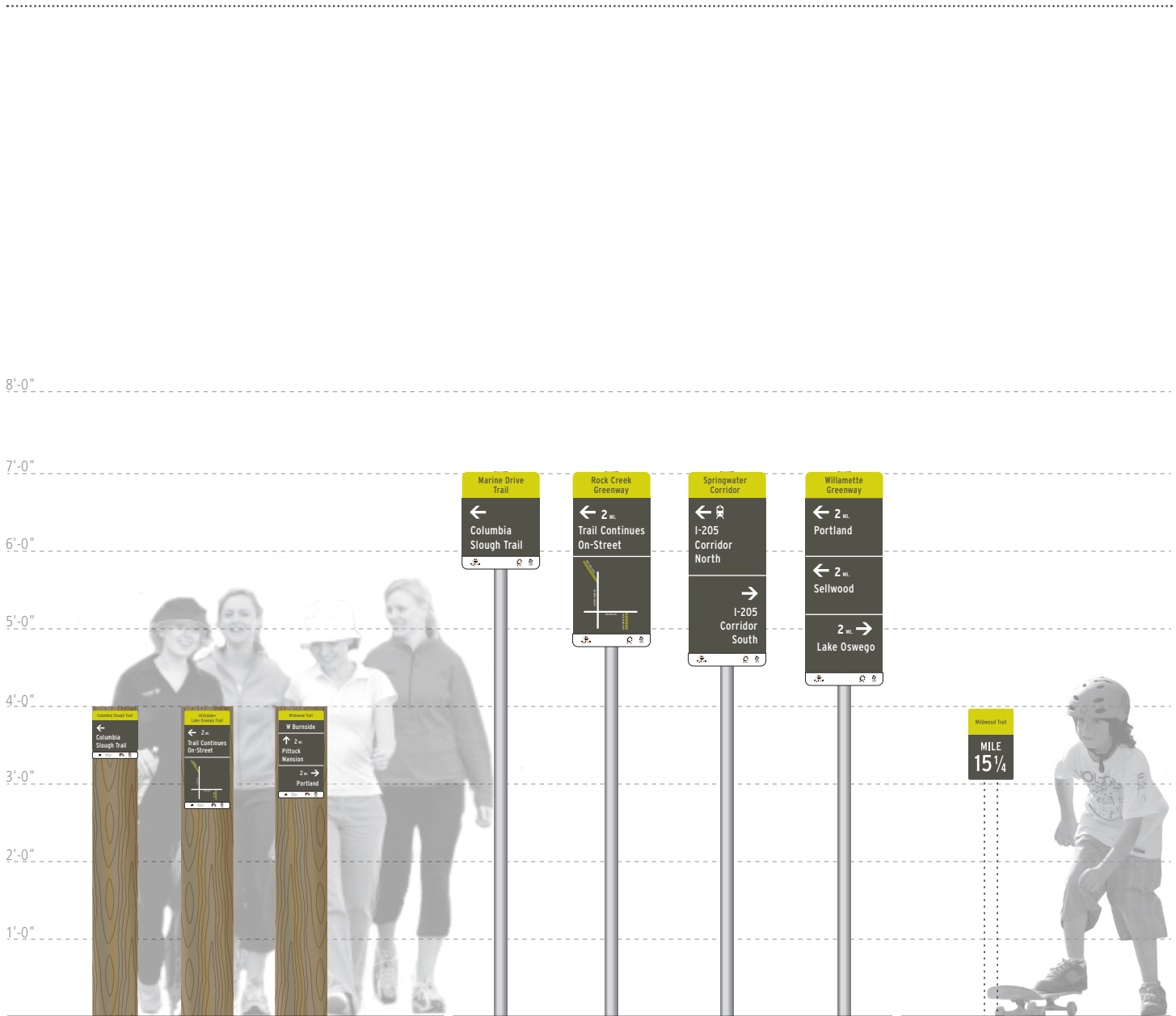

SIGN TYPE C: Off-Street Pedestrian Directional

This sign type is located along an off-street pedestrian-only regional trail to provide directional information.

Layouts on page 4.17

SIGN TYPE D: Off-Street Multi-Use Directional

This sign type is located along an off-street multi-use regional trail to provide directional information.

Layouts on page 4.23

SIGN TYPE E: Mile Marker

This sign type is located at 1/4 mile increments along a regional trail.

Layouts on page 4.29

2.04 Sign Family

On-Street Connection Signs

THE INTERTWINE: Regional Trails Signage Guidelines
May 17, 2012

On-Street Connection Signs

Use these Sign Types along street rights-of-way that connect off-street trail segments.

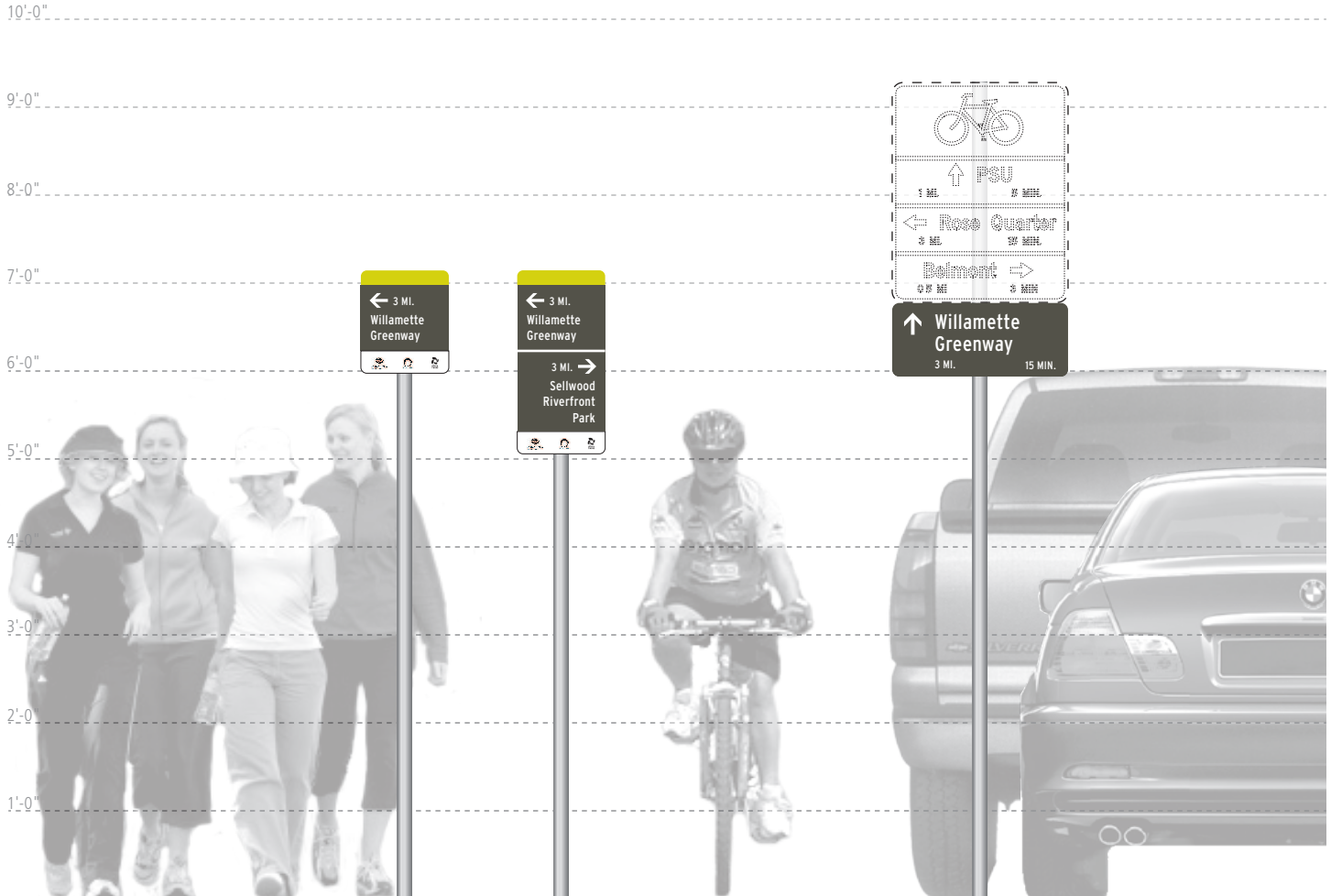

SIGN TYPE F: On-Street Pedestrian Directional

This sign type is located in the street right-of-way to provide directions and continuity to off-street trail segments.

Layouts on page 4.33

SIGN TYPE G: On-Street Bicycle Directional

This sign type is located in the street right-of-way to connect bicyclists between the off-street trail segments. The MUTCD allows The Intertwine sign on-street as long as they are oriented to bicyclists/pedestrians and not to traffic (9B.02). It will be up to the jurisdiction whether to allow this sign type.

Layouts on page 4.39

The Intertwine Logo Components

Use these components to identify the trail as part of the Regional Trail Network.

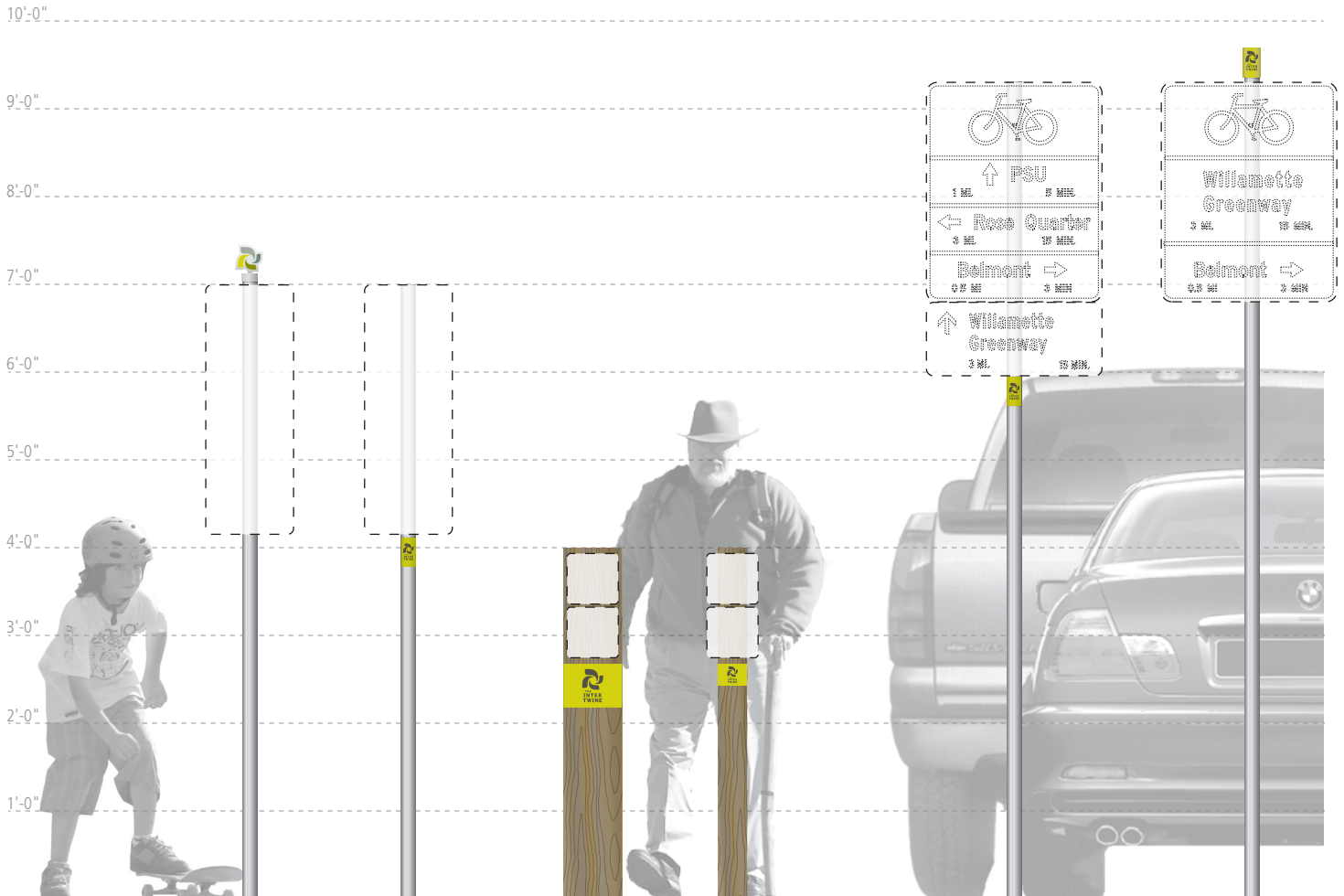

SIGN TYPE H: The Intertwine Logo

This sign type is used in combination with other off-street regional trail and on-street connection signs. Examples illustrate how to add The Intertwine logo to various types of existing and new signs.

Layouts on page 4.43

.....

Section 3: Sign Location and Planning

- 3.02** Trail Scenario 1: Trail Connections
- 3.04** Trail Scenario 2: Trail Intersections
- 3.06** Trail Scenario 3: Trail Spurs
- 3.08** Application of The Intertwine Logo to Existing Signs

Trail Scenario 1: Trail Connections

The following examples illustrate the types of signs and messages to consider when off-street trail segments are connected via an on-street route.

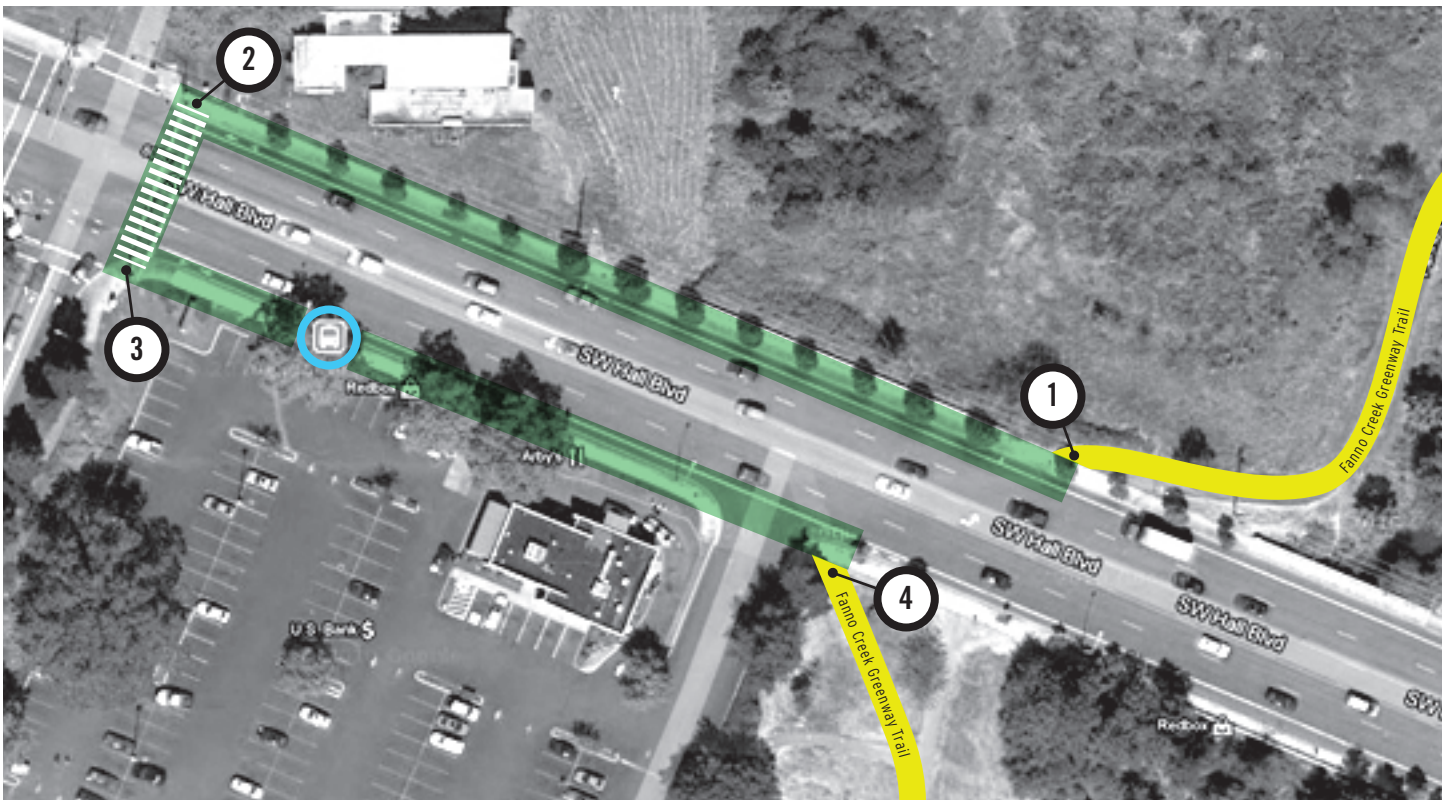

1
This is an access point for the trail. **Sign Type B** can be used to provide the trail name as well as mode of travel.

This is also the point where the trail continues via an on-street connection. **Sign Type C** or **D** (depending on mode of travel) can be used to inform the user of the street name and how to connect to the next off-street trail segment using the nearest crosswalk. If there was a transit stop in the immediate vicinity, the symbol for it could be included in the message.

2 & 3
Sign Type F can be used at this location to direct and reinforce the path the user should take to connect to the off-street trail segment.

4
This is an access point for the trail. **Sign Type B** can be used to provide the trail name as well as mode of travel.

This is also the point where the trail continues via an on-street connection. **Sign Type C** or **D** (depending on mode of travel) can be used to identify the street name and how to connect to the next off-street trail segment. Directions to transit in the immediate vicinity may be included.



1
Sign Type F can be used at this location to direct and reinforce the path the pedestrian should take to connect to the off-street trail segment.

2
This is an access point for the trail.
Sign Type B can be used to provide the trail name as well as mode of travel.

This is also the point where the trail continues via an on-street connection. Assuming this is a multi-use trail, **Sign Type D** can be used to inform the user of the street name and how to connect to the next off-street trail segment using the nearest crosswalk.

Mayer/Reed

3
Sign Type D can be used at this location to direct to the on-street connection. Consider using a map to reinforce the route the user will take between off-street trail segments.

4
Consider using **Sign Type D** at this location to indicate "End of Trail".

5
In the vicinity of this location, consider using **Sign Type G** in the right-of-way to direct Bicyclists and **Sign Type F** out of the right-of-way for pedestrians to connect to the next on-street trail segment. **Sign Type H3** can be added

to the post of **Sign Type G** to identify the route as part of The Intertwine.

6 & 7
Consider using **Sign Type F** at this location to direct and reinforce the path the pedestrian should take to connect to the off-street trail segment. **Sign Type G** (with **H3**) can be used to reinforce the path for bicyclists but should be placed in the right-of-way.

8
This is an access point for the trail as well as the point where the trail meets the on-street connection, sign this location similar to location 2 using **Sign Types B** and **D**.

3.04 Sign Location Planning

Trail Scenario 2

THE INTERTWINE: Regional Trails Signage Guidelines
May 17, 2012

Trail Scenario 2: Trail Intersections

The following examples illustrate the types of signs and messages to consider when trails intersect off-street.

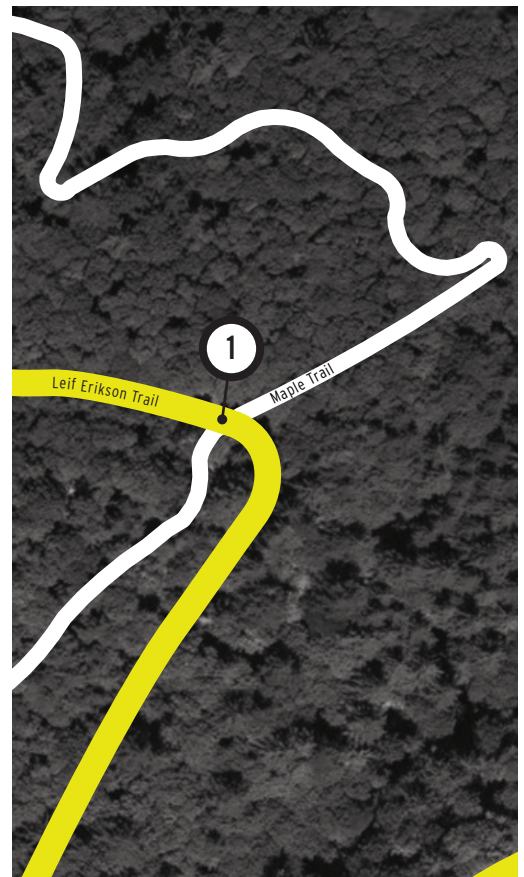
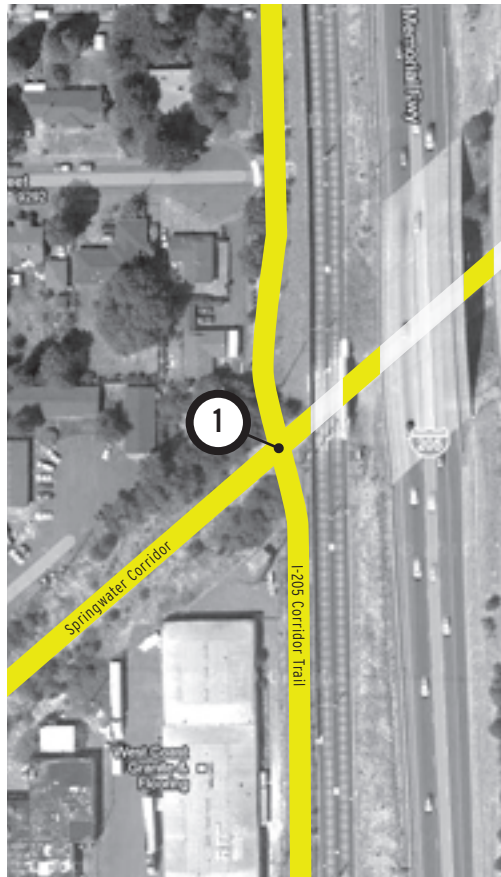

1

Depending on mode of travel, use **Sign Type C** or **D** to direct to the regional (or non-regional) intersecting trail. To orient the user, use cardinal directions (North, South, East, West) after the trail name. If there is an amenity along the trail or in the immediate vicinity, such as a transit stop, restrooms, etc., those symbols can be included in the destination message.

If the intersecting trail is non-regional, the signage installed along the regional trail should direct to the non-regional trail as a destination with orienting cardinal directions. Amenities should only be included with the destination if the local trail signage supports it or if the amenity is within the immediate vicinity.

Entering the regional trail, the jurisdiction should provide signage as necessary so that regional trail messages are available from all directions.

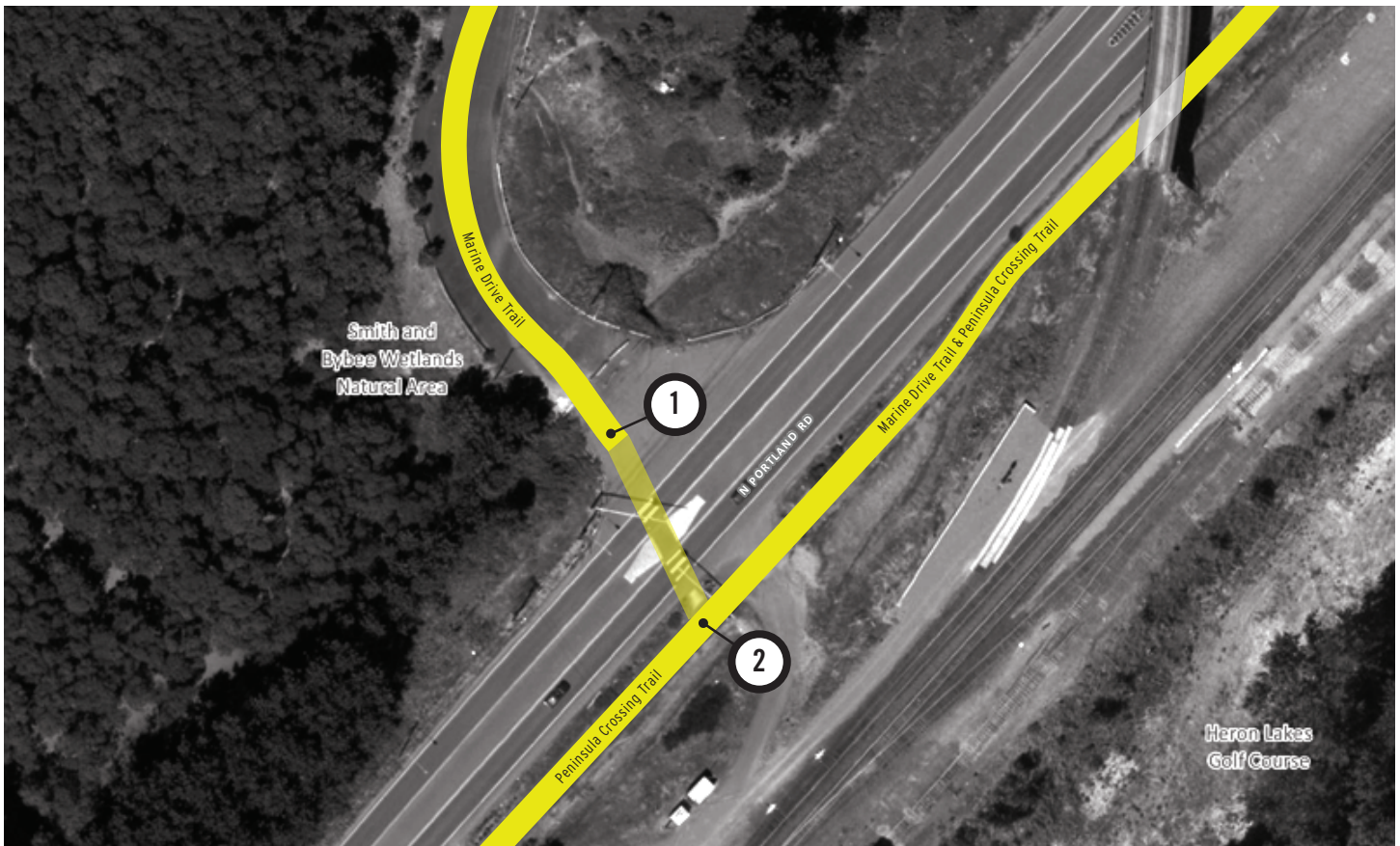

1

This is an access point for the trail. **Sign Type B** can be used to provide the trail name as well as mode of travel.

This is also the point where the trail intersects with another trail. Assuming this is a multi-use trail, **Sign Type D** can be used to direct to the intersecting trail. If there is transit or another amenity in the immediate vicinity, consider including the symbol for it in the directional message.

2

This location is also a trail access point. **Sign Type B** should be located facing the street. Directional panels should be included to direct to end destinations (Portland, Gresham) or cardinal directions (North, South, East, West) to orient the user.

Perpendicular to **Sign Type B**, use **Sign Type D** to direct to the intersecting trail as well as any destinations and amenities ahead.

3.06 Sign Location Planning

Trail Scenario 3

THE INTERTWINE: Regional Trails Signage Guidelines
May 17, 2012

Trail Scenario 3: Trail Spurs

The following examples illustrate the types of signs and messages to consider when a trail spurs off to connect to transit, an amenity, a street or a destination.

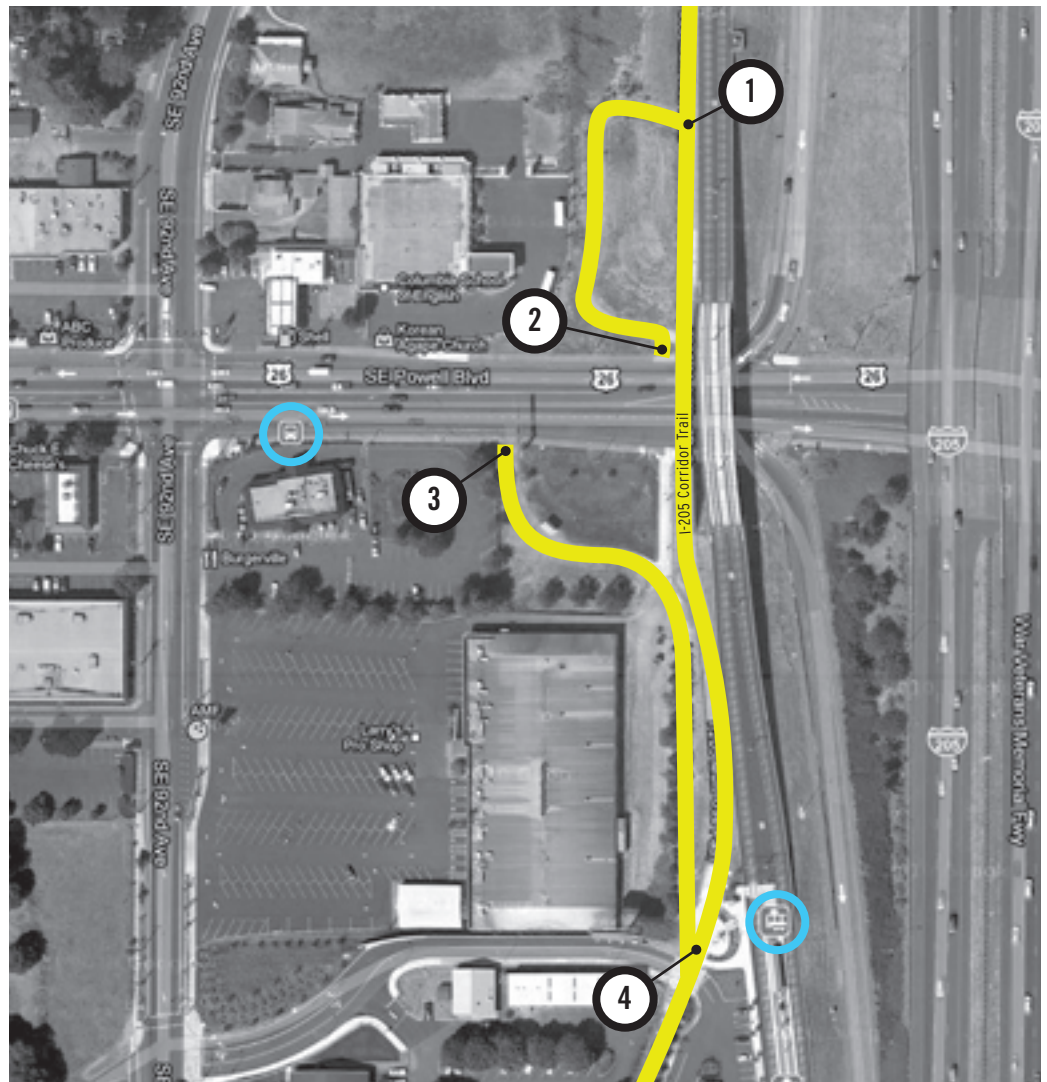

1
Assuming the trail is multi-use, **Sign Type D** can be used to inform the user of the amenities such as street name and transit located off the trail spur as well as any destinations ahead.

2 & 3
This is an access point for the trail. Entering the trail, **Sign Type B** can be used to provide the trail name as well as mode of travel.

Exiting the trail, **Sign Type D** can be used to inform the user of the street name, transit in the immediate vicinity as well as cardinal directions (North, South, East, West) or city destinations (Portland, Gresham) to orient the user. Landmark destinations such as parks and districts should only be directed

to if there is adequate bicycle and/or pedestrian on-street signage leading to that destination or if the destination is in the immediate vicinity.

In this example, signage at location 3 can direct to transit since the stop is on the same side of the street and therefore in the immediate vicinity.

4
In this location, **Sign Type D** can be used to inform the user of the amenities such as street name and transit located off the trail spur, destinations ahead as well as the MAX line immediately off the trail. This would be an example of transit being a stand alone destination.

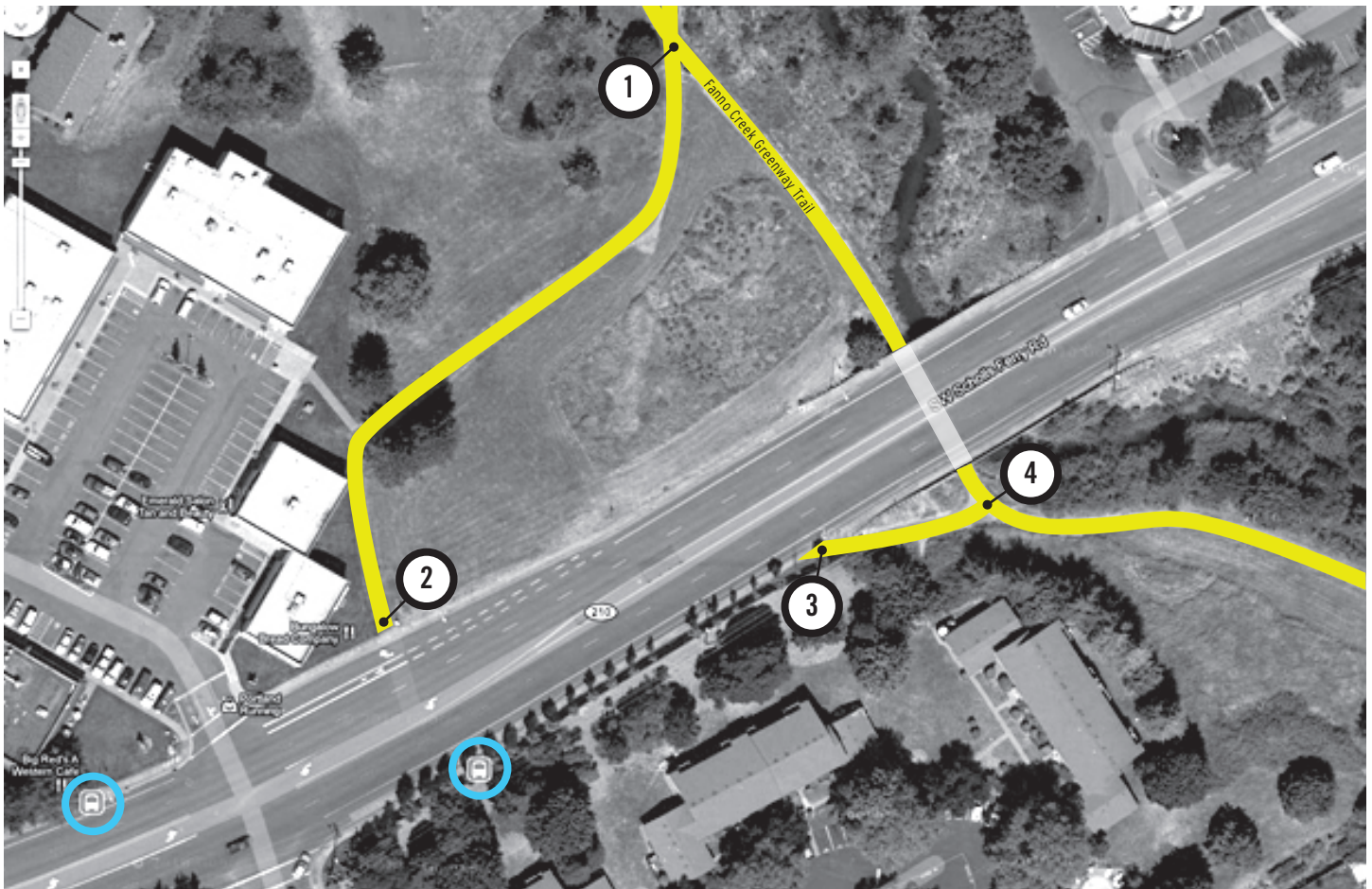

1 & 4

At this location, **Sign Type C** or **D** (depending on mode of travel) can be used to inform the user of the amenities such as street name and transit located off the trail spur as well as any destinations ahead.

2 & 3

This is an access point for the trail. Entering the trail, **Sign Type B** can be used to provide the trail name as well as mode of travel.

Exiting the trail, **Sign Type C** or **D** (depending on mode of travel) can be used to inform the user of the street name, transit in the immediate vicinity as well as cardinal directions (North, South, East, West) or city destinations (Portland, Gresham) to orient the user.

Landmark destinations such as parks and districts should only be directed to if there is adequate bicycle and/or pedestrian on-street signage leading to that destination or if the destination is in the immediate vicinity.

In this example, signage at both locations 2 & 3 can direct to transit since the stop is on the same side of the street and within in the immediate vicinity.

3.08 Sign Location Planning

Application of The Intertwine Logo
to Existing Signs

THE INTERTWINE: Regional Trails Signage Guidelines
May 17, 2012

Application of The Intertwine Logo to Existing Signs

In multiple cases, a sign program, apart from the designs shown in these guidelines, are in use along off-street regional trails and on-street connections. Multiple options can be used to integrate The Intertwine logo and identify the trail as a part of the Regional Trail Network and The Intertwine. The following examples give options on how to do so. Refer to **Sign Type H** in Section 4 for fabrication details.

Since The Intertwine is not a single trail but rather a network of trails, the logo is not used as a directional sign with an arrow.



1 & 3

These examples illustrate the option of applying an aluminum sign with The Intertwine logo to an existing wood sign post.

2

This example illustrates the option of applying a small vinyl wrap with The Intertwine logo to an existing wood or steel sign post.

4

This example illustrates the option of painting The Intertwine logo in a bike lane (or sidewalk) along an on-street trail connection as allowable by individual jurisdictions. (MUTCD 3B.20, pg 387, 2009 edition)



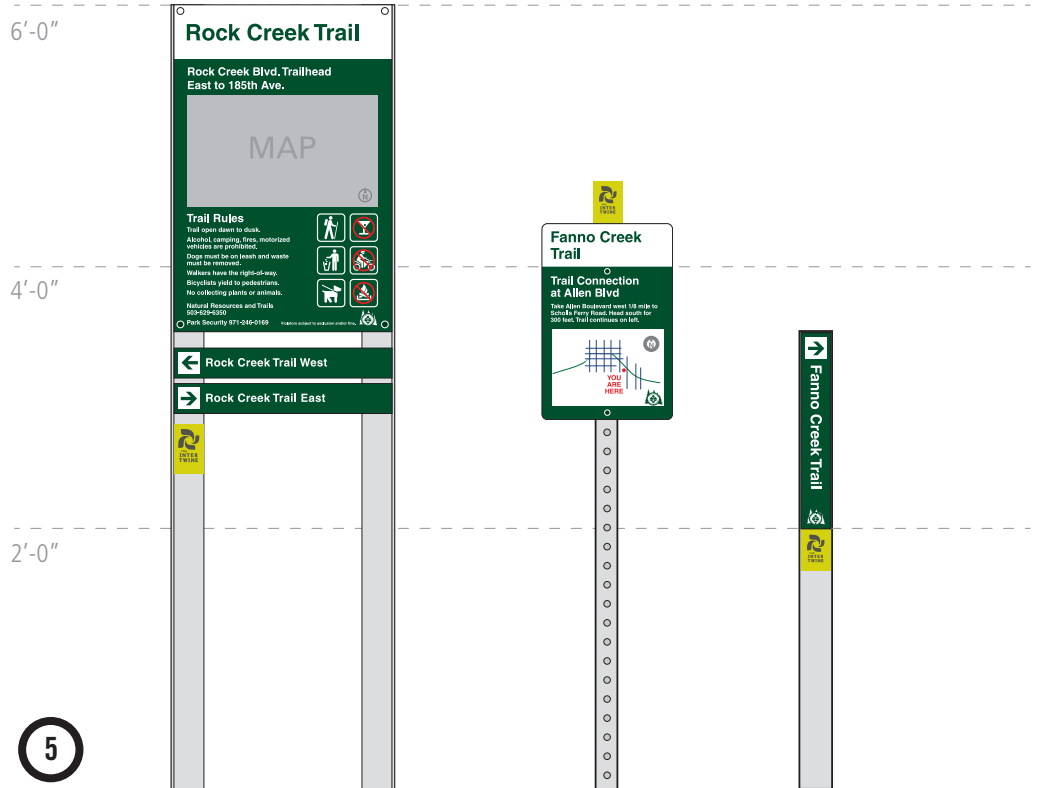

5
 This example illustrates multiple options for applying The Intertwine logo to different types of signs in the same sign system. Examples shown include vinyl badges and a post cap.

6 & 7
 These examples show The Intertwine logo integrated into the trail signage design and applied adjacent to the jurisdiction logo.



6



7

.....

Section 4: Fabrication Details

- 4.02** Sign Panel Fabrication: Option 1
- 4.03** Sign Panel Fabrication: Option 2
- 4.04** Sign Panel Fabrication: Option 3
- 4.05** Typical Sign Placement & Mounting Hardware
- 4.07** Sign Type A: Trailhead Sign Overview
- 4.11** Sign Type B: Trail Access Sign Overview
- 4.17** Sign Type C: Off-Street Pedestrian Directional Sign Overview
- 4.23** Sign Type D: Off-Street Multi-Use Directional Sign Overview
- 4.29** Sign Type E: Mile Marker Sign Overview
- 4.33** Sign Type F: On-Street Pedestrian Directional Sign Overview
- 4.39** Sign Type G: On-Street Bicycle Directional Sign Overview
- 4.43** Sign Type H: Intertwine Logo Components Overview
- 4.48** Symbols
- 4.50** Trail Map
- 4.51** Typography
- 4.52** Colors
- 4.53** Logos

4.02
Fabrication Details

Sign Panel Fabrication

Sign Panel Fabrication: Option 1

This method describes the standard fabrication process for all sign types with the exception of Sign Type G. Refer to Fabrication Method 2 for Sign Type G.

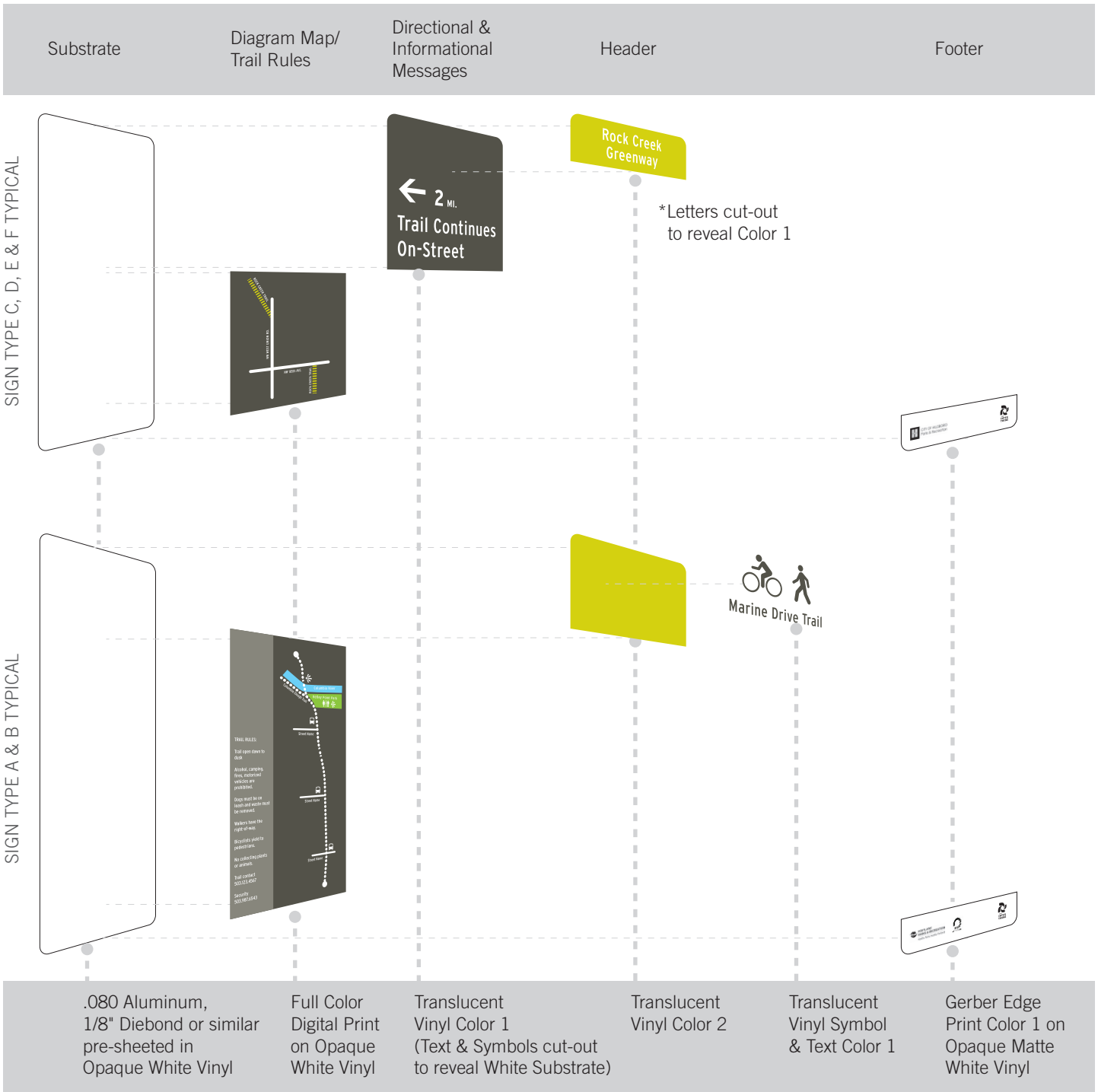

Sign Panel Fabrication: Option 2

This method allows for night time reflectivity. As required for on-street signage, Sign Type G will have full panel reflectivity. For all other sign types, only the Header and Directional/Informational Message components will be reflective.

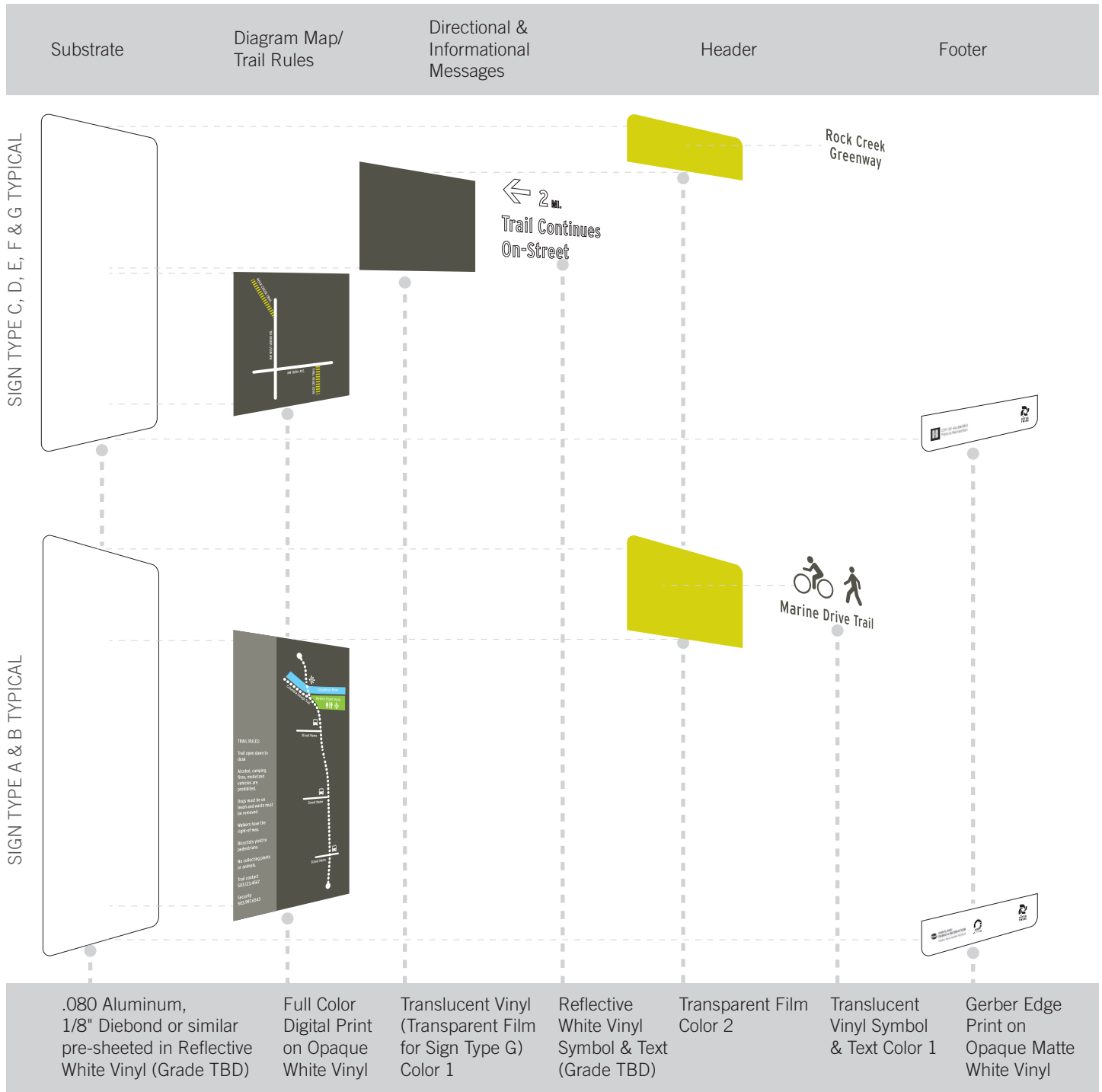

4.04
Fabrication Details

Sign Panel Fabrication

Sign Panel Fabrication: Option 3



While this fabrication method can be used for all sign types with the exception of Sign Type G, it is best suited for sign types with diagrammatic maps such as Sign Type B.

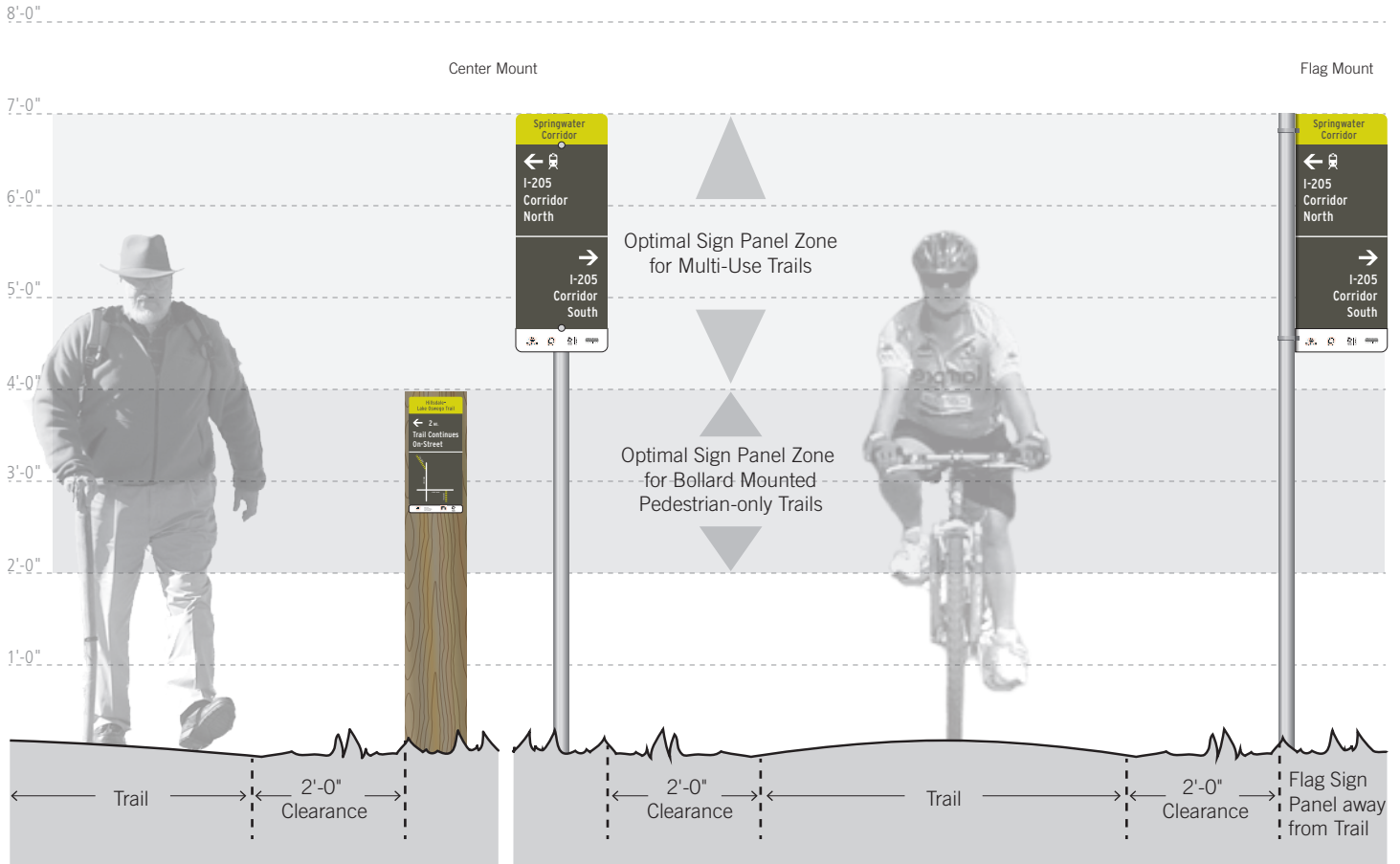

Typical Sign Placement & Mounting Hardware

For mounting on-street, please follow MUTCD standards

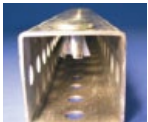
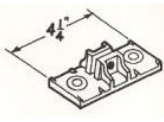
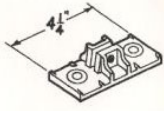

Hardware				
Center Mount		Post/Pole Options	Flag Mount	
	THDW-105 Single Bracket #16500800 or THDW-107 Double Bracket #16501000	2" Round Galvanized or Powder Coated Color 2		Wing Bracket #16503700
	3/8" Drive Rivet (Anti-Theft) Aluminum or Steel	2" Square Galvanized or Powder Coated Color 2		Flat Back Bracket w/ 3/8"x3" Bolt (Galvanized, Zinc Plated or Powder Coated Color 2)
	3/8" Lag Bolt, Galvanized with Stainless Steel Washer & Nylon washer	Wood		Flat Back Bracket w/ 3/8"x3" Bolt (Galvanized, Zinc Plated or Powder Coated Color 2)

Brackets available locally through Traffic Safety Supply Co. 503.235.8531

.....

Sign Type A: Trailhead Sign Overview

Fabrication:

Single or double-sided pylon with internal framing, similar construction methods to the pylons in The Intertwine Branding Manual.

Layouts:

Refer to layout dimensions on the following pages.

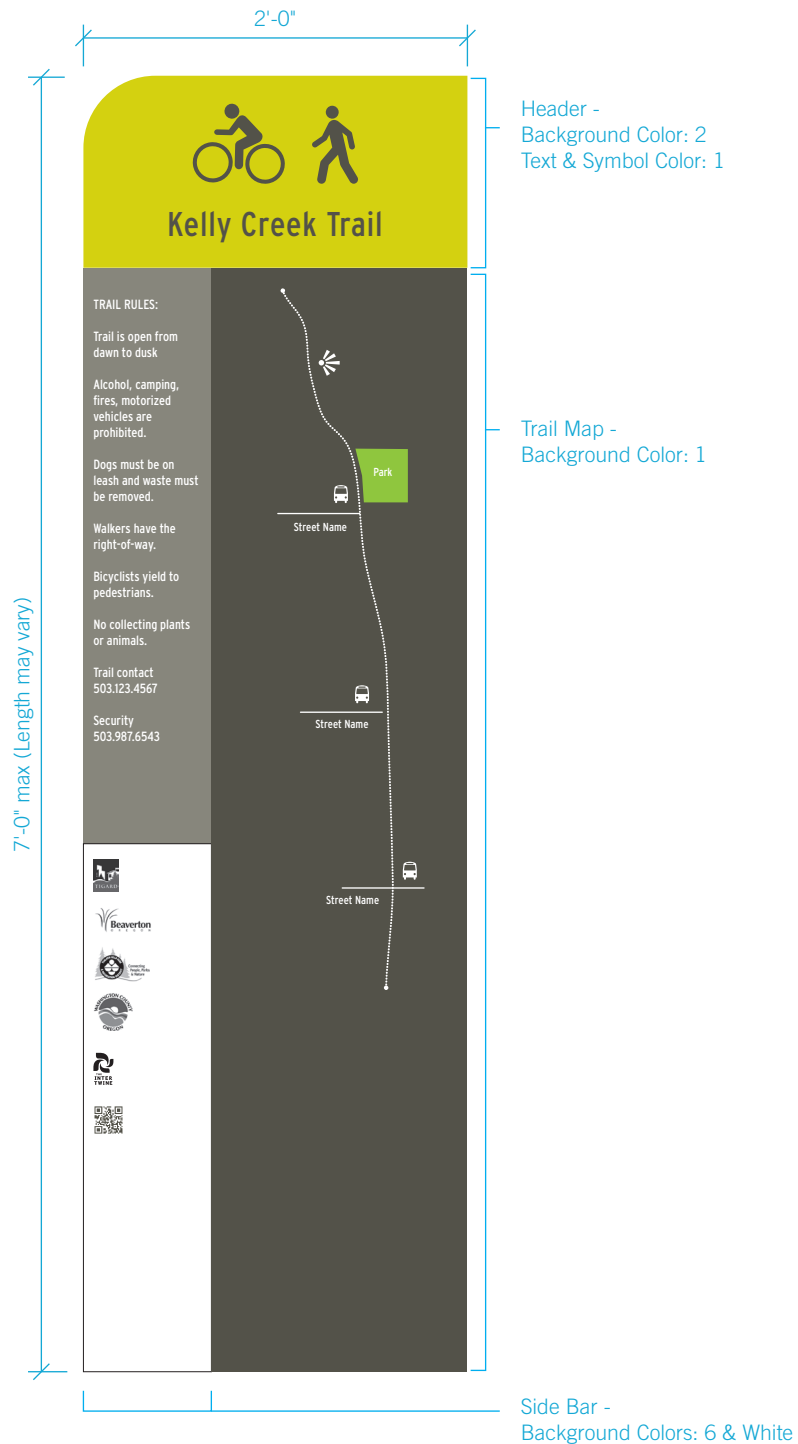

4.08 Fabrication Details

Sign Type A Layouts

Sign Type A: Header Layouts

Single Line Header:

Use to identify the trail name and mode of travel. Trail logos should not appear in the Header but rather the Side Bar.

Refer to Symbols on page 4.48.

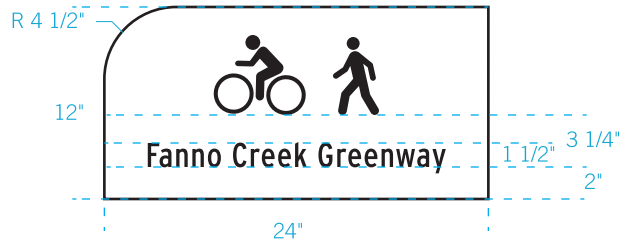

Double Line Header:

Use to identify the trail name and mode of travel. Trail logos should not appear in the Header but rather the Side Bar.

Refer to Symbols on page 4.48.

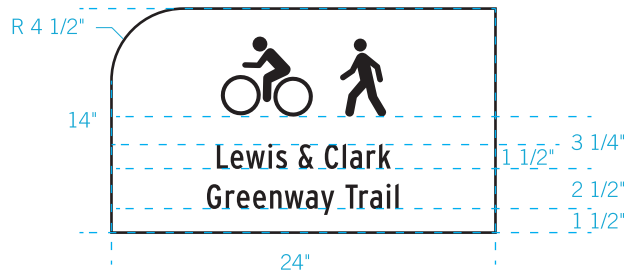

Sign Type A: Side Bar Layout

Side Bar:

This layout integrates all rules and regulations, contact information as well as Jurisdiction/Partner and applicable trail and trail system logos associated with the trail. Regulatory symbols can also be placed in this section as necessary. All Jurisdiction/ Partner logos should be separated from rules and regulatory section and should be placed in a white background.

Refer to Logos starting on page 4.53.

Refer to Symbols on page 4.48.

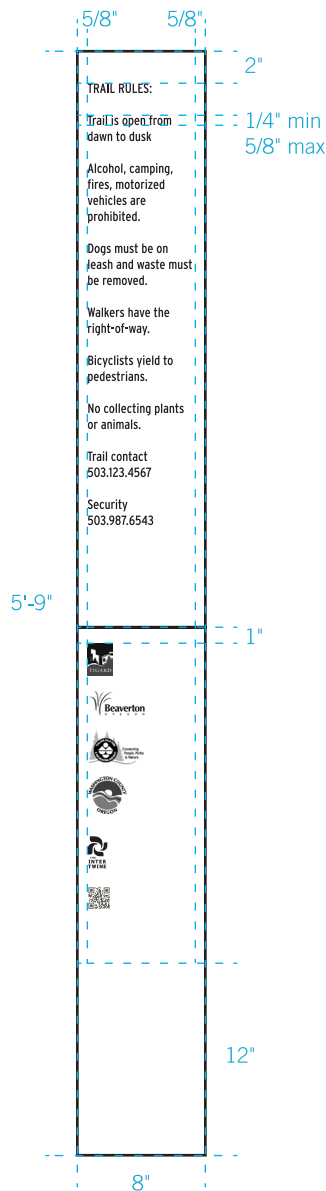

4.10 Fabrication Details

Sign Type A Layouts

Sign Type A: Trail Map Layout

Trail Map:

Map artwork can be used at trailheads to illustrate distance, amenities, landmarks as well as other features in the environs of the trail. Map artwork should not exceed beyond the lower 12" portion of the panel.

Refer to page 4.50 for trail map artwork guidelines.

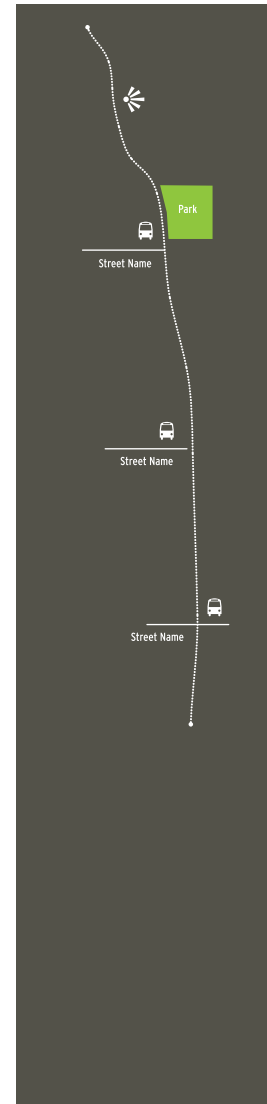
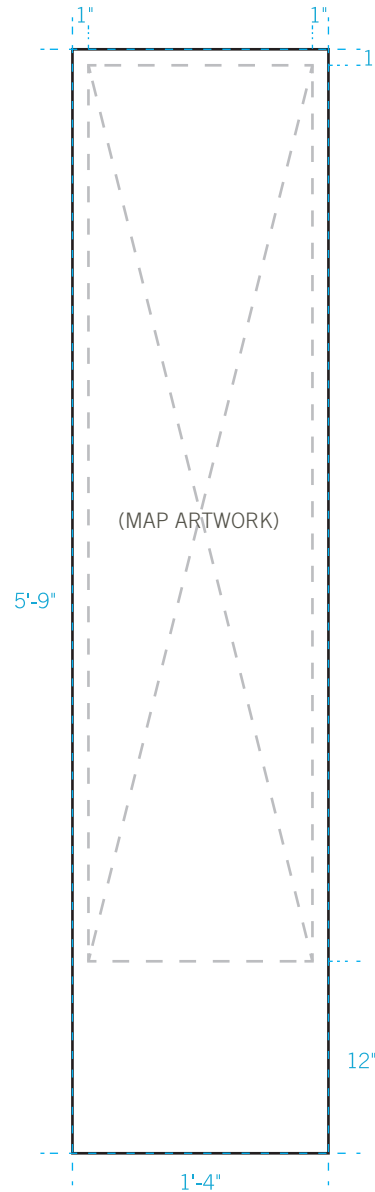

Sign Type B: Trail Access Sign Overview

Layouts:

Refer to layout dimensions on the following pages.

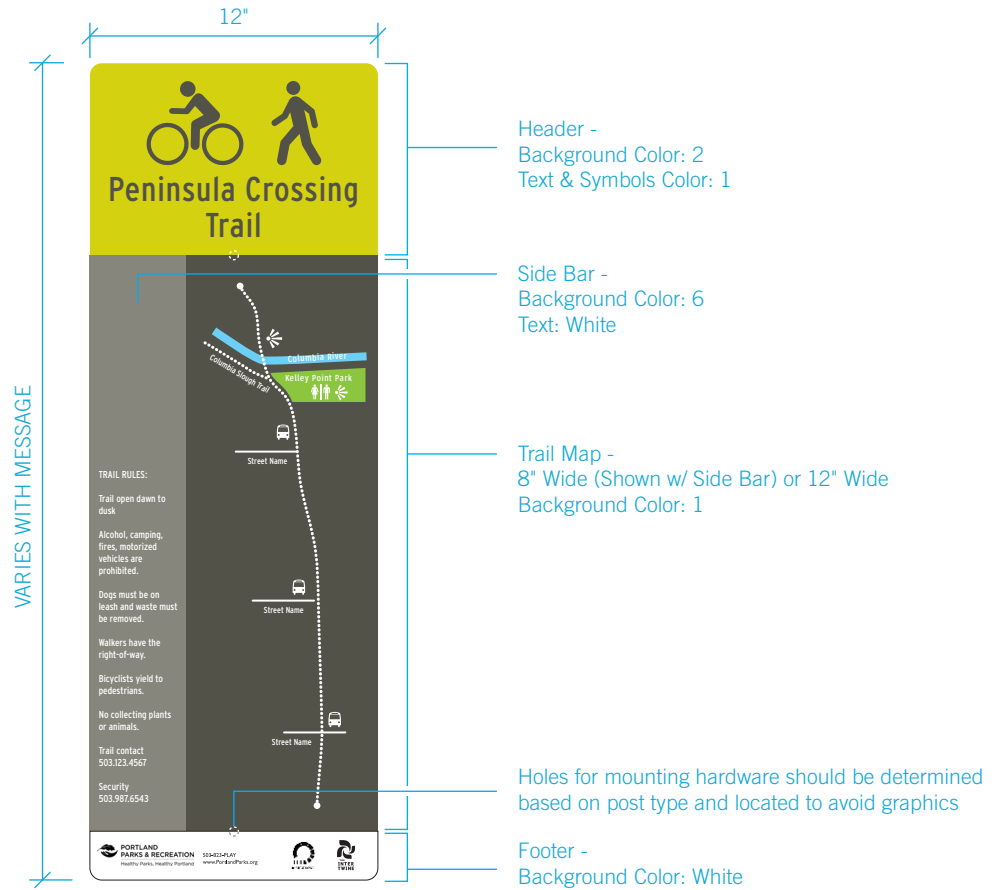

4.12 Fabrication Details

Sign Type B Layouts

THE INTERTWINE: Regional Trails Signage Guidelines
May 17, 2012

Sign Type B: Header Layouts

Single Line Header:

Use to identify the trail name and mode of travel.

Trail logos should not appear in the Header but rather the Logo Footer.

Refer to Symbols on page 4.48.



Double Line Header:

Use to identify the trail name and mode of travel.

Trail logos should not appear in the Header but rather the Logo Footer.

Refer to Symbols on page 4.48.



Sign Type B: Side Bar Layout

Side Bar:

This layout integrates the rules and regulations associated with the trail. Regulatory symbols can also be placed in this section as necessary. This layout is to be used adjacent the 8" Wide Trail Map Layout.

Refer to Symbols on page 4.48.

Refer to Logos on page 4.53.

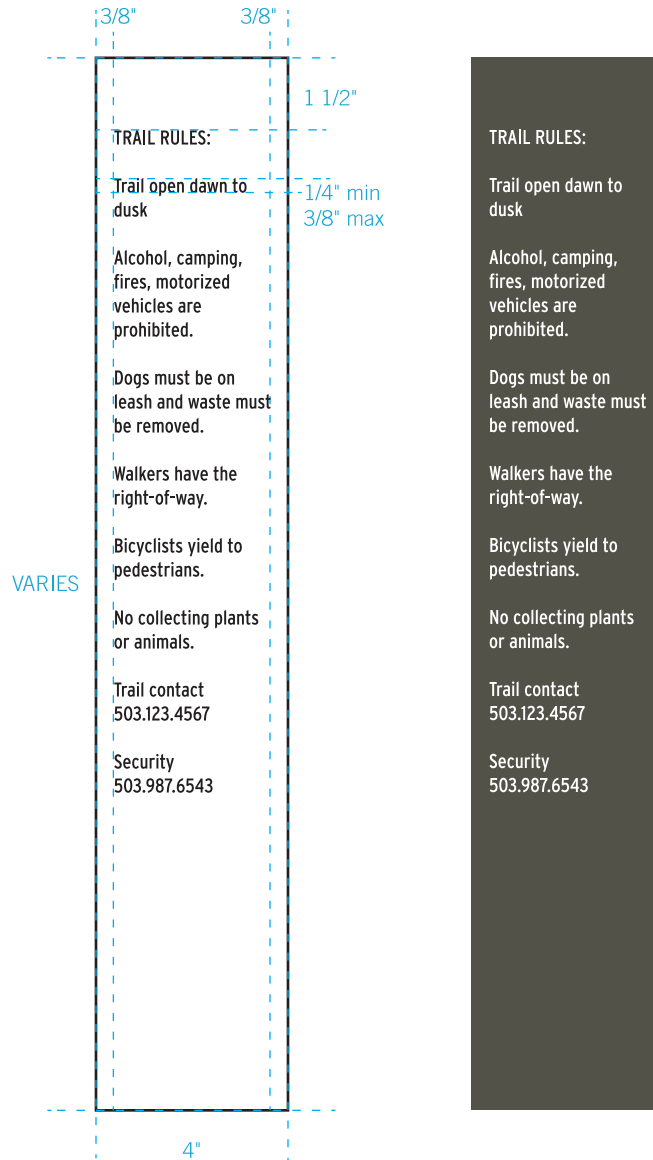

4.14 Fabrication Details

Sign Type B Layouts

Sign Type B: Trail Map Layouts

8" Wide Trail Map:

This area can be used to display a trail map illustrating amenities, transit and landmarks within the vicinity. This layout is to be used adjacent to the Side Bar Layout.

Refer to page 4.50 for trail map artwork guidelines.

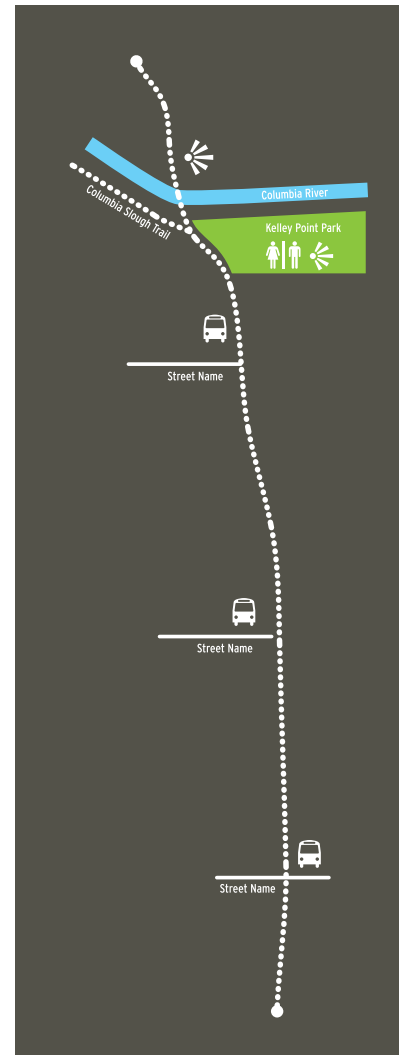
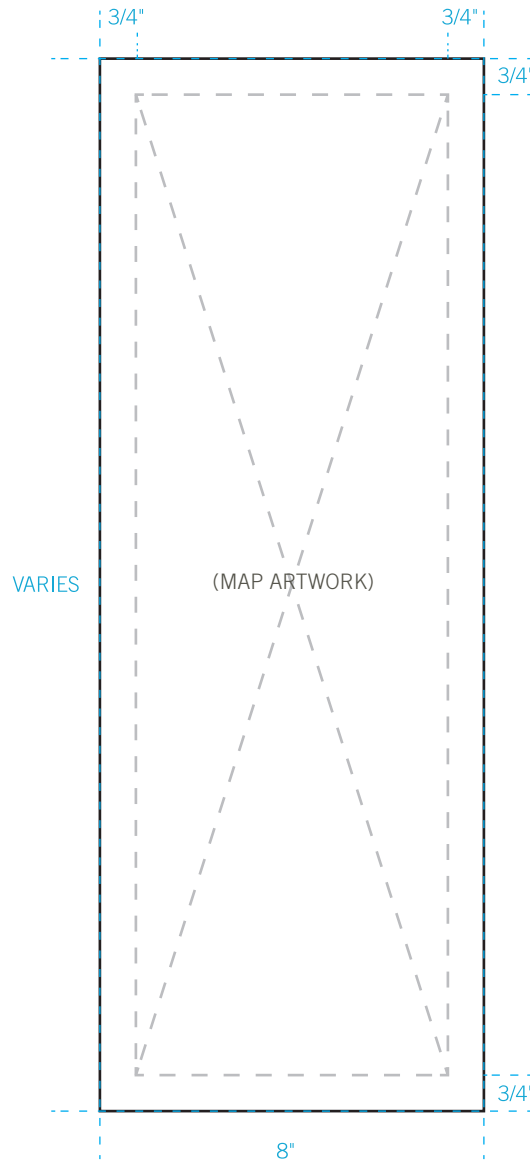

12" Wide Trail Map:

When a combination of the Side Bar and 8" Wide Trail Map is not applicable, the 12" Wide Trail Map is an option. The trail map can illustrate amenities, transit and landmarks within a vicinity of the location.

Refer to page 4.50 for trail map artwork guidelines.

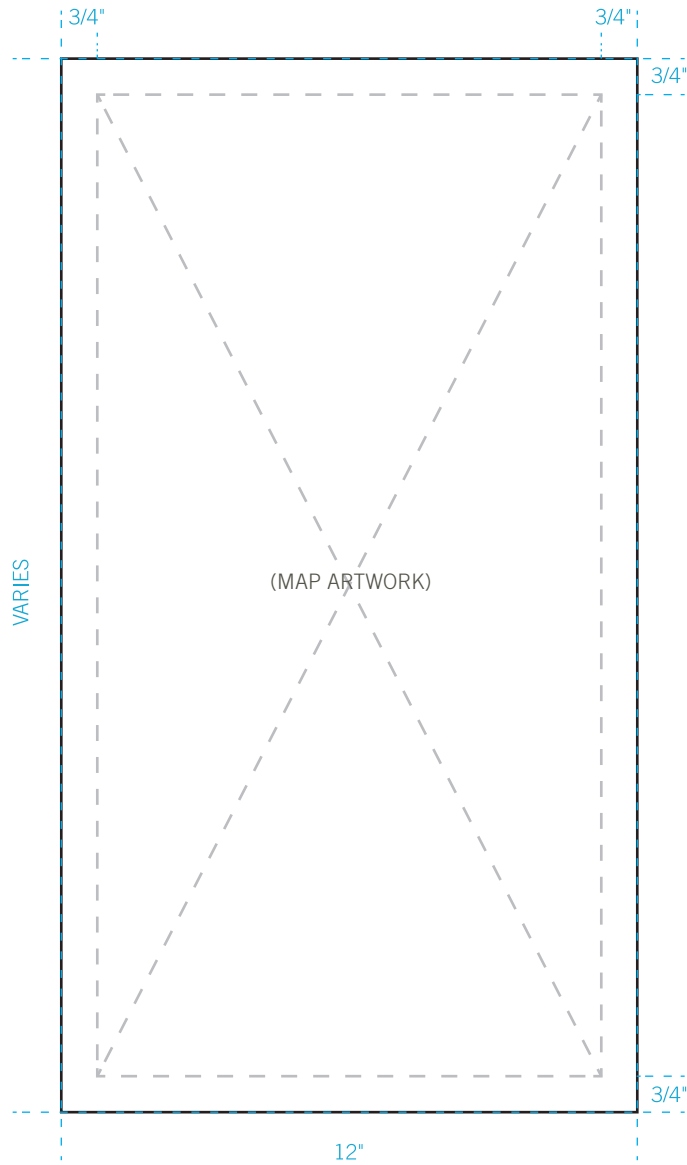

4.16 Fabrication Details

Sign Type B Layouts

THE INTERTWINE: Regional Trails Signage Guidelines
May 17, 2012

Sign Type B: Logo Footer Layout

Logo Footer:

Use to display the Jurisdiction's logo and contact information, Partner's logo, the Trail or Trail System logo as well as The Intertwine logo.

Refer to Logos starting on page 4.53.



Sign Type C: Off-Street Pedestrian Directional Sign Overview

Layouts:

Refer to layout dimensions on the following pages.

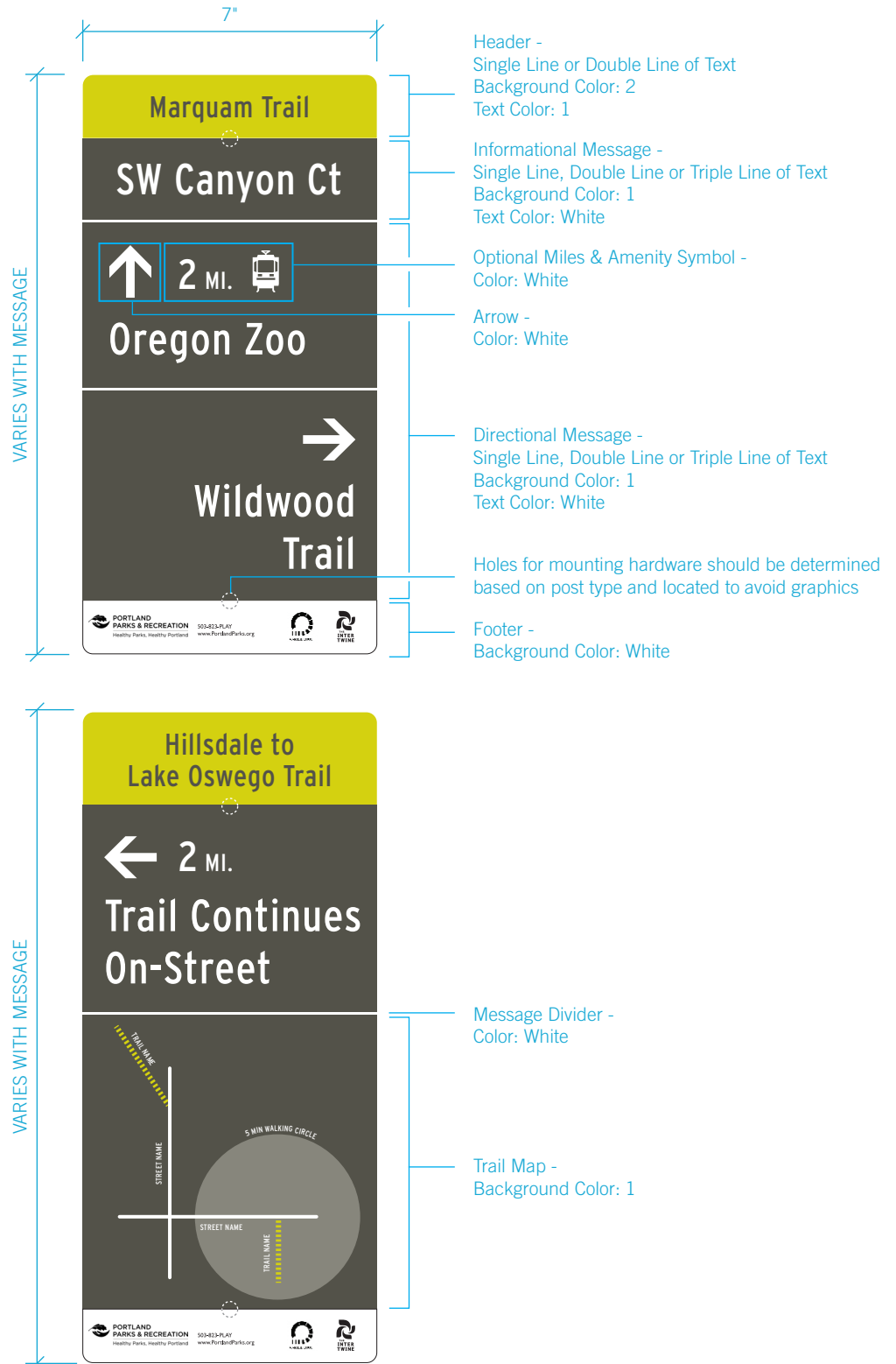

4.18
Fabrication Details

Sign Type C Layouts

Sign Type C: Header Layouts

Single Line Header:

Use to identify the trail name.

Trail logos should not appear in the Header but rather the Logo Footer.

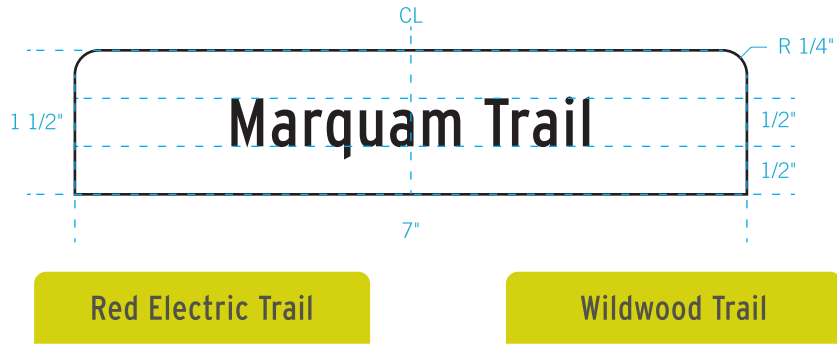

Double Line Header:

Use to identify the trail name.

Trail logos should not appear in the Header but rather the Logo Footer.

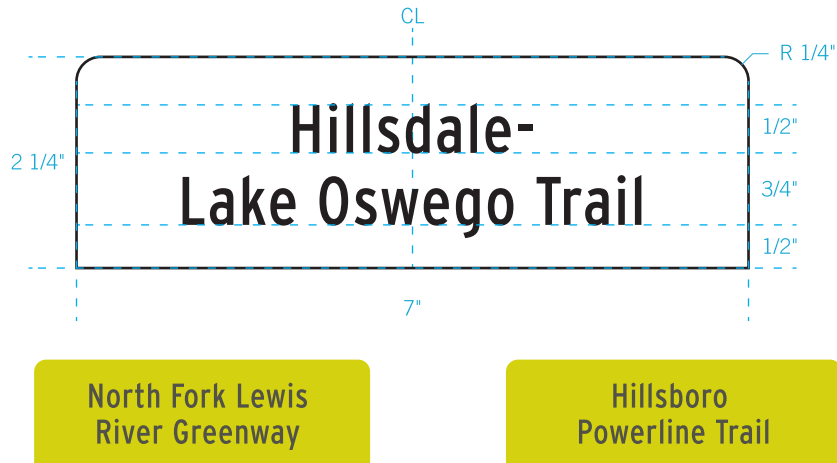

Sign Type C: Informational & Directional Layouts

Single Line Informational Message:

Use to identify the street name at a trail crossing.

This panel size can also be used to direct to an amenity within the vicinity that is not associated with a directional message.

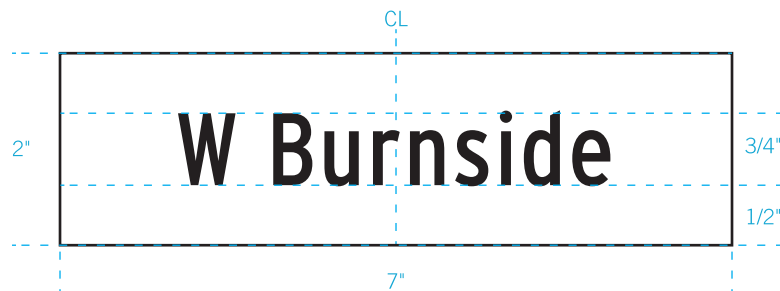

* Refer to following layouts for amenity dimensions.



Sign Type C: Informational & Directional Layouts

Double Line Informational Message:

Use to identify the street name at a trail crossing.

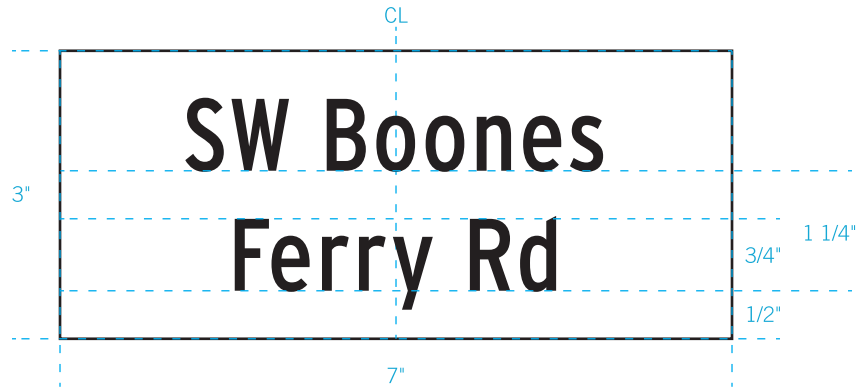

Message Divider:

Use the white divider to separate message layouts.



Do not use adjacent to the Header or the Logo Footer.

Single Line Directional Message:

Use to direct to a destination identified within a single line of text.

Layout and dimensions can be mirrored to example shown in order to correspond to direction. (i.e. right justified for destinations to the right)

Refer to Symbols on page 4.48.

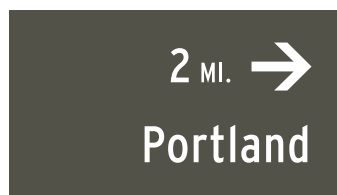
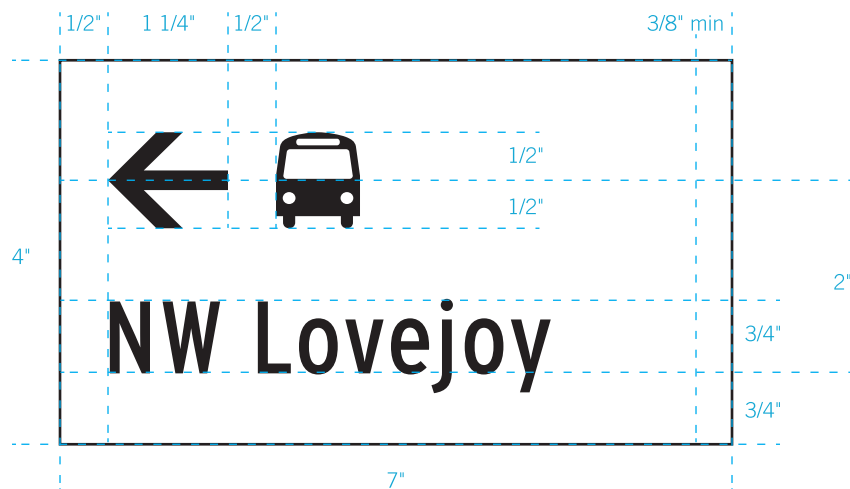

4.20 Fabrication Details

Sign Type C Layouts

THE INTERTWINE: Regional Trails Signage Guidelines
May 17, 2012

Sign Type C: Informational & Directional Layouts

Double Line Directional Message:

Use to direct to a destination identified within two lines of text.

Layout and dimensions can be mirrored to example shown in order to correspond to direction. (*i.e. right justified for destinations to the right*)

Refer to Symbols on page 4.48.



Sign Type C: Informational & Directional Layouts

Triple Line Directional Message:

Use to direct to a destination identified within three lines of text.

Layout and dimensions can be mirrored to example shown in order to correspond to direction. (i.e. left justified for destinations to the left)

Refer to Symbols on page 4.48.

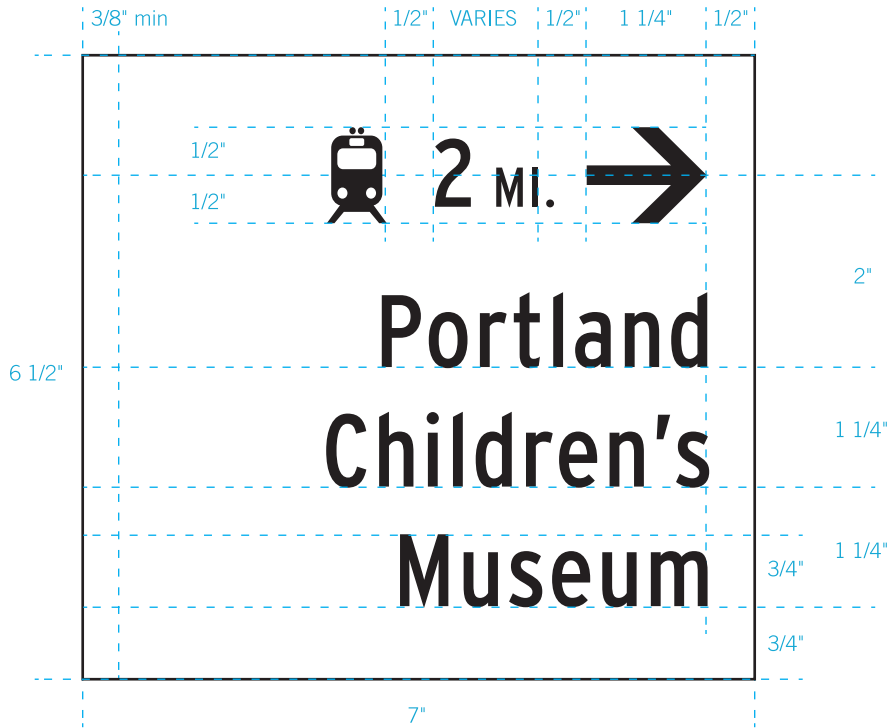

Trail Map:

Use as support to directionals to illustrate how to connect off-street trail segments via an on-street connection.

Refer to page 4.50 for trail map artwork guidelines.

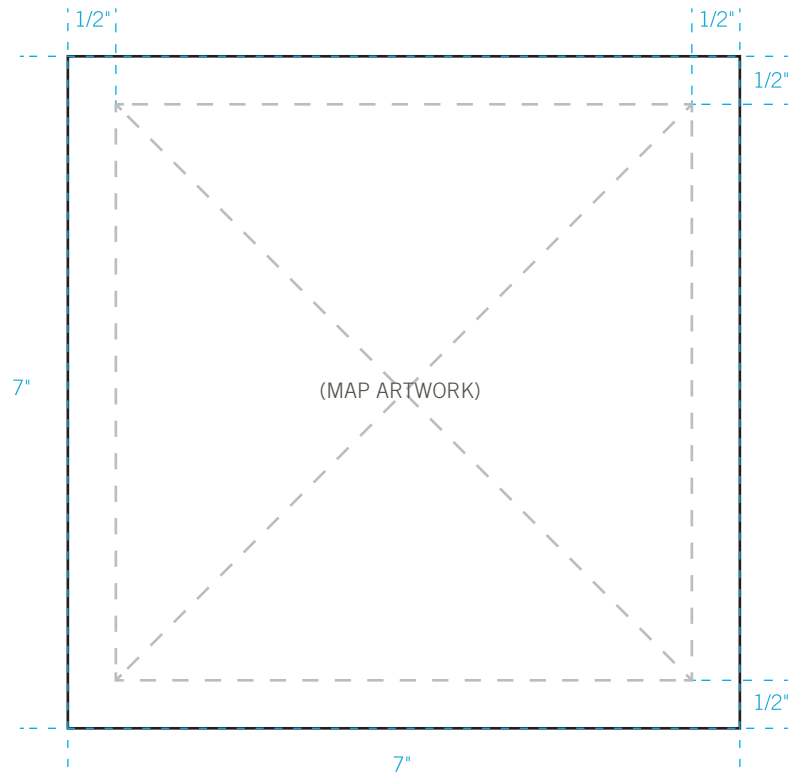

4.22 Fabrication Details

Sign Type C Layouts

THE INTERTWINE: Regional Trails Signage Guidelines
May 17, 2012

Sign Type C: Logo Footer Layout

Logo Footer:

Use to display the Jurisdiction's logo and contact information, Partner's logo, the Trail or Trail System logo as well as The Intertwine logo.

Refer to Logos starting on page 4.53.



Sign Type D: Off-Street Multi-Use Directional Sign Overview

Layouts:

Refer to layout dimensions on the following pages.

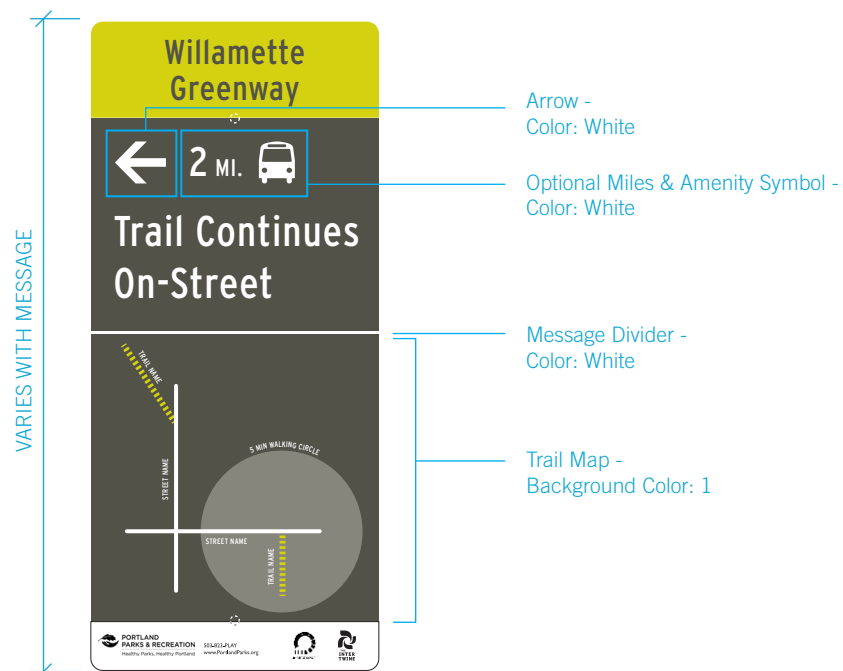
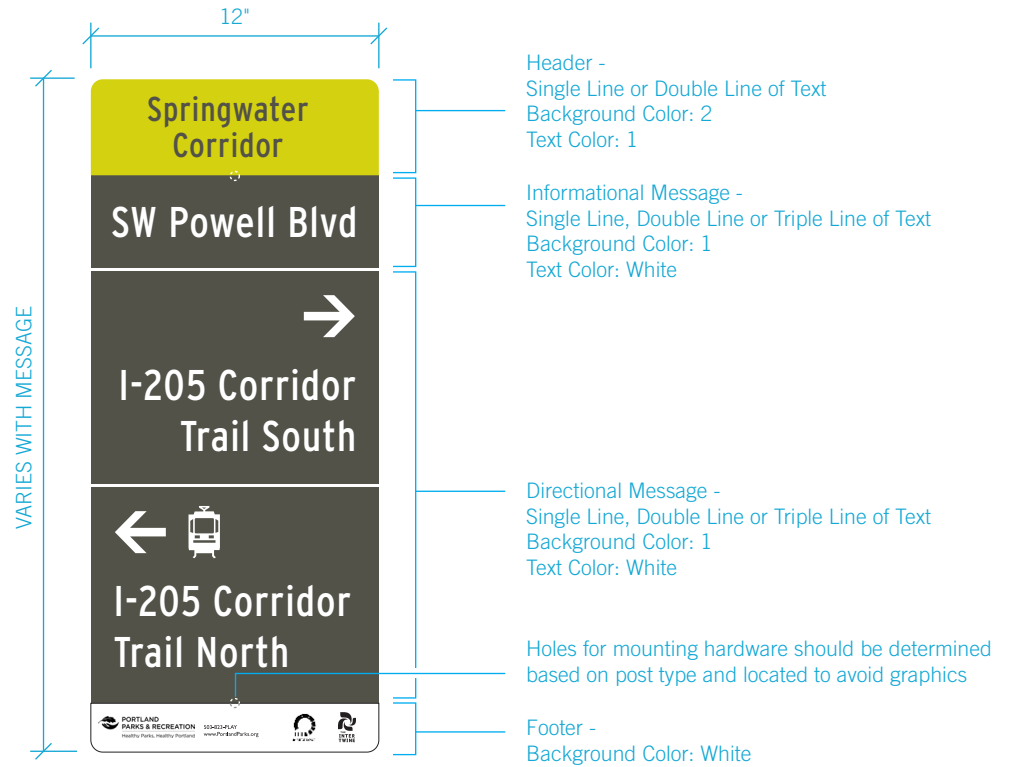

4.24
Fabrication Details

Sign Type D Layouts

Sign Type D: Header Layouts

Single Line Header:

Use to identify the trail name.

Trail logos should not appear in the Header but rather the Logo Footer.

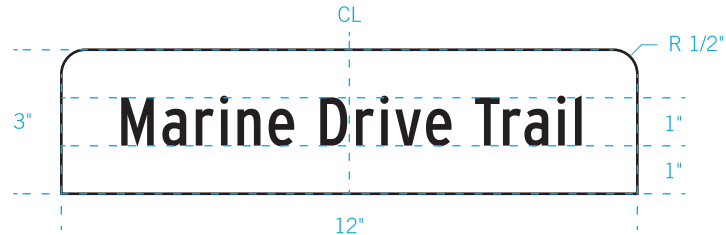

Double Line Header:

Use to identify the trail name.

Trail logos should not appear in the Header but rather the Logo Footer.



Sign Type D: Informational & Directional Layouts

Single Line Informational Message:

Use to inform the user of the street name at a trail crossing. This panel size can also be used to direct to an amenity within an immediate vicinity that is not associated with a directional message.

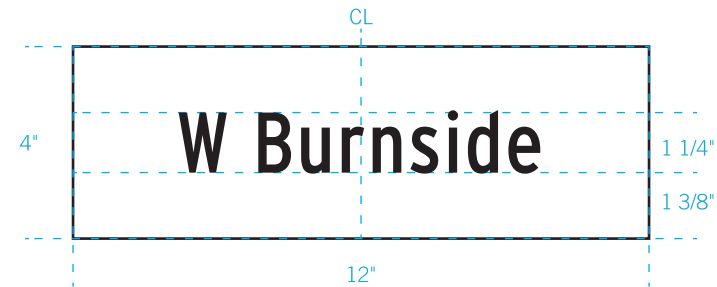

* For amenity directionals, refer to following directionals for typical layout dimensions.

Refer to Symbols on page 4.48.

Sign Type D: Informational & Directional Layouts

Double Line Informational Message:

Use to inform the user of the street name at a trail crossing.

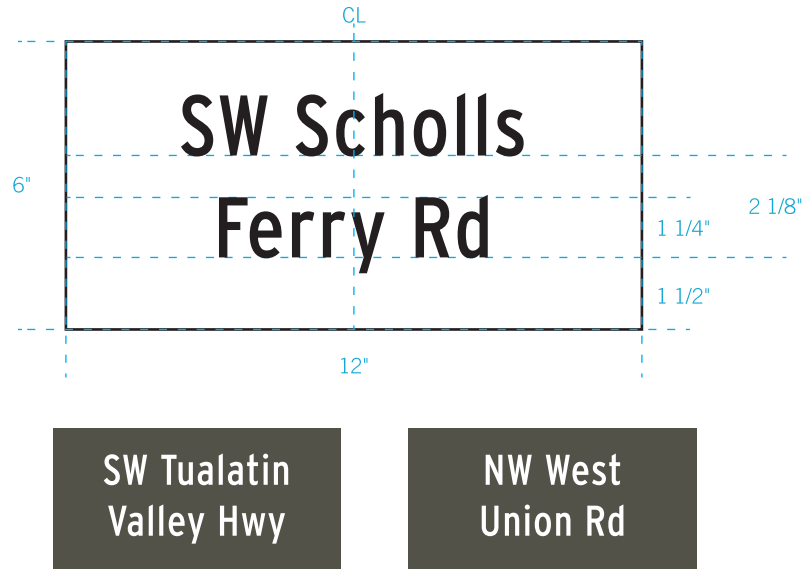

Single Line Directional Message:

Use to direct to a destination identified within a single line of text.

Layout and dimensions can be mirrored to example shown in order to correspond to direction. (i.e. right justified for destinations to the right)

Refer to Symbols on page 4.48.

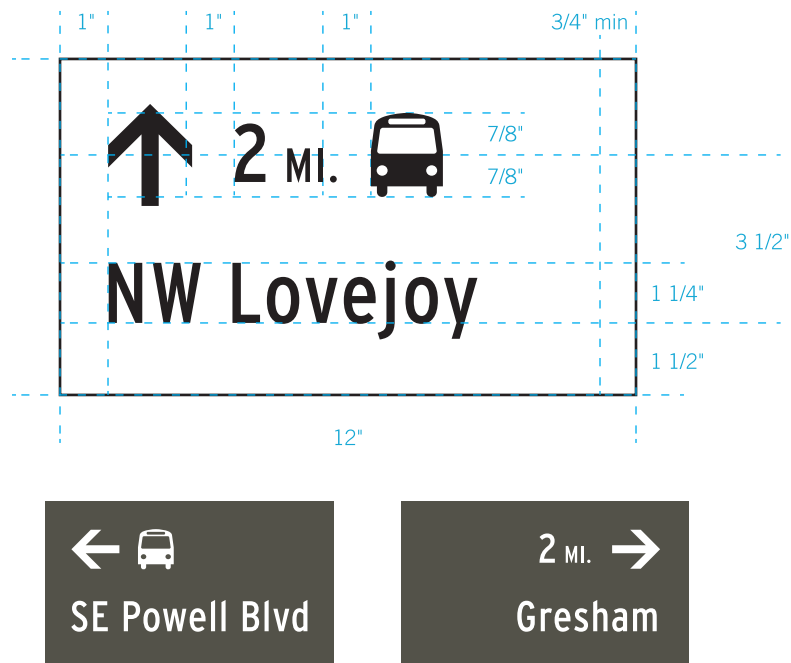

4.26 Fabrication Details

Sign Type D Layouts

THE INTERTWINE: Regional Trails Signage Guidelines
May 17, 2012

Sign Type D: Informational & Directional Layouts

Message Divider:

Use the white divider to separate message layouts.



Do not use adjacent the Header or the Logo Footer.

Double Line Directional Message:

Use to direct to a destination identified within two lines of text.

Layout and dimensions can be mirrored to example shown in order to correspond to direction. (i.e. right justified for destinations to the right)

Refer to Symbols on page 4.48.

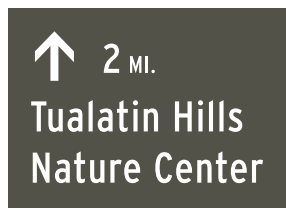
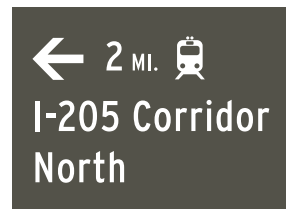
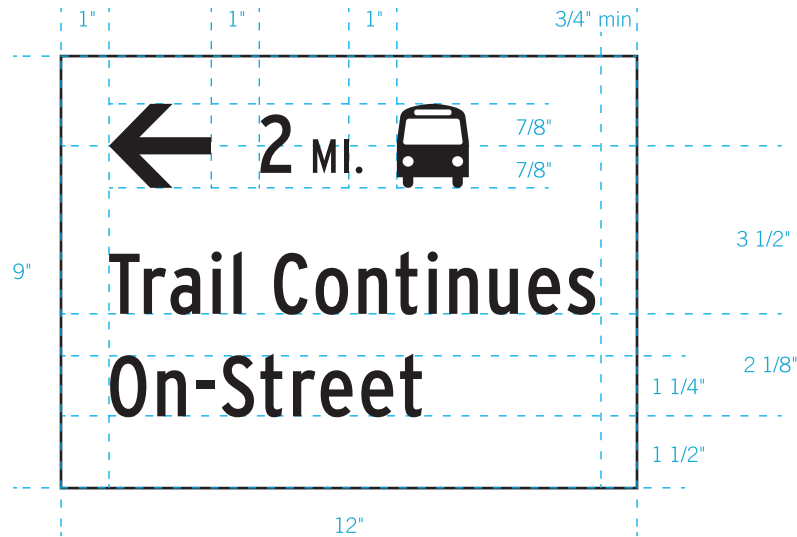

Sign Type D: Informational & Directional Layouts

Triple Line Directional Message:

Use to direct to a destination identified within three lines of text.

Layout and dimensions can be mirrored to example shown in order to correspond to direction. (i.e. left justified for destinations to the left)

Refer to Symbols on page 4.48.

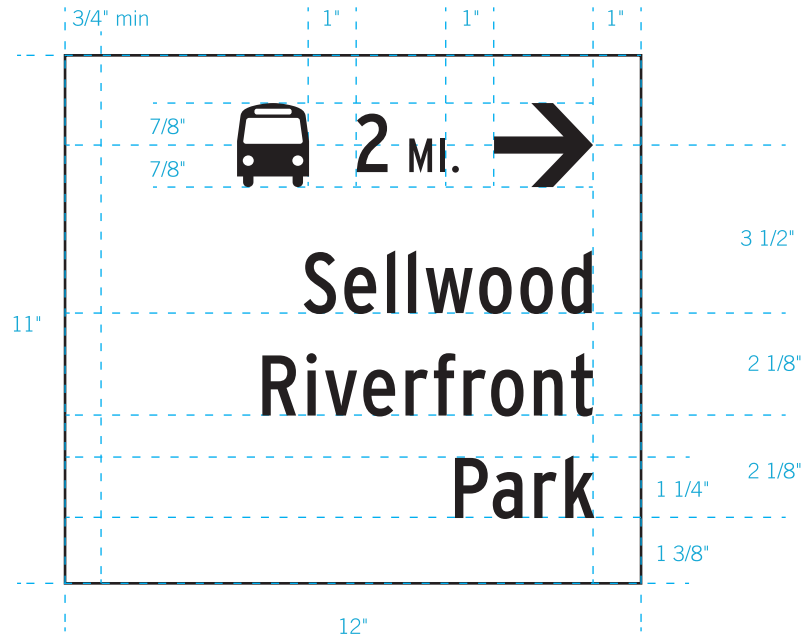

Trail Map:

Use as support to directionals to illustrate how to connect off-street trail segments via an on-street connection.

Refer to page 4.50 for trail map artwork guidelines.

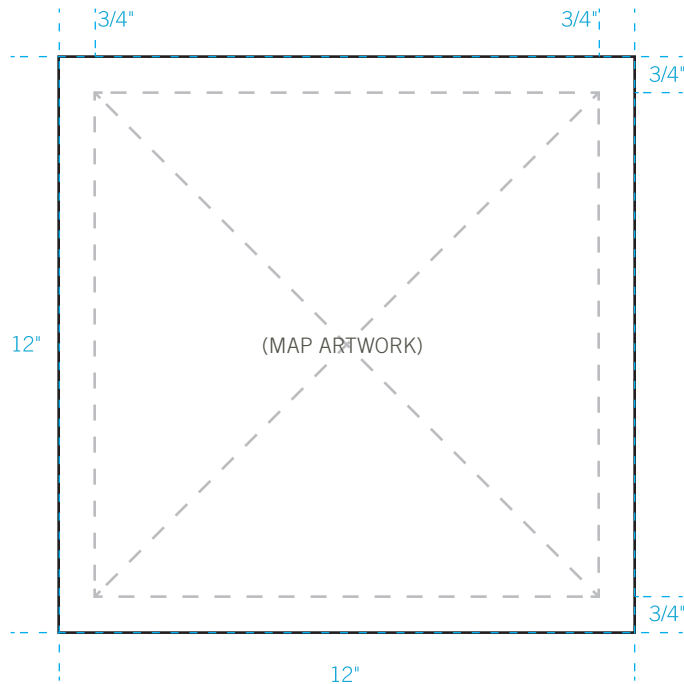

4.28 Fabrication Details

Page Title

Sign Type D: Logo Footer Layout

Logo Footer:

Use to display the Jurisdiction's logo and contact information, Partner's logo, the Trail or Trail System logo as well as The Intertwine logo.

Refer to Logos starting on page 4.53.



Sign Type E: Mile Marker Sign Overview

Layouts:

Refer to layout dimensions on the following pages.

Alternate Application:

The layouts for this sign type can be adapted for use as asphalt markings.

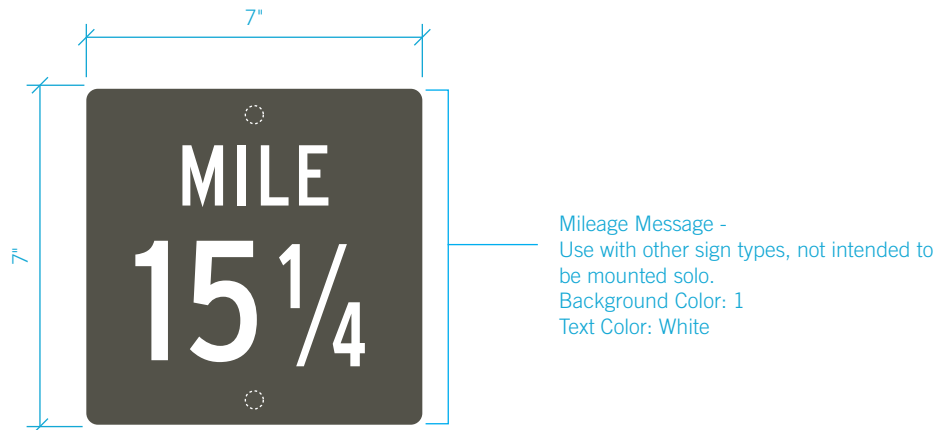
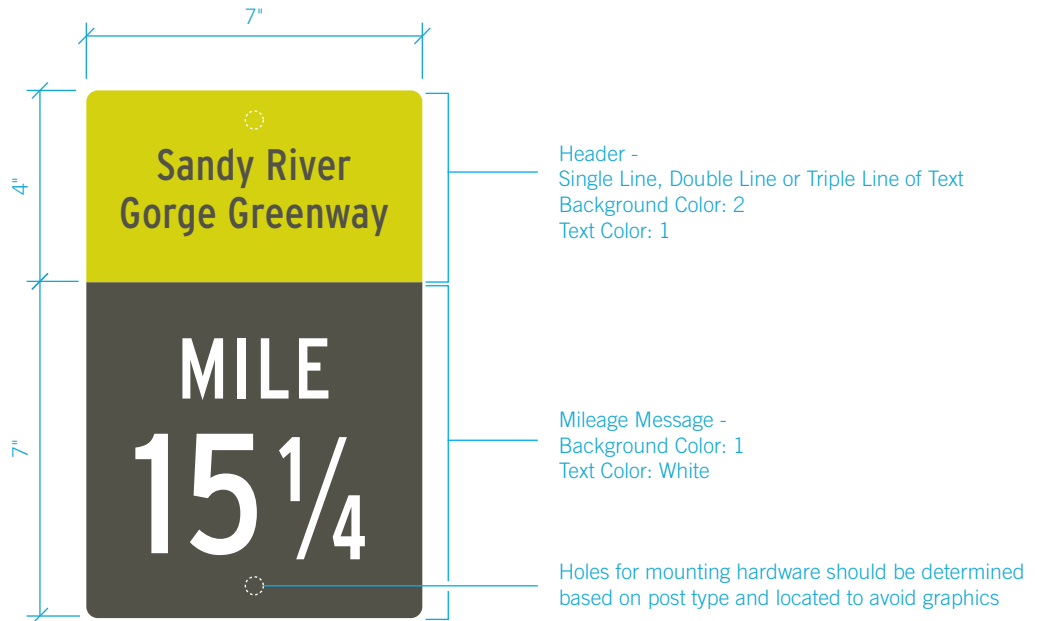

4.30
Fabrication Details

Sign Type E Layouts

Sign Type E: Layouts

Single Line Header w/ Mile Message:

Use to identify the trail name and the mile along the trail.

Layouts for double and triple line trail names are shown on the following page.

Logos do not appear on this sign type.

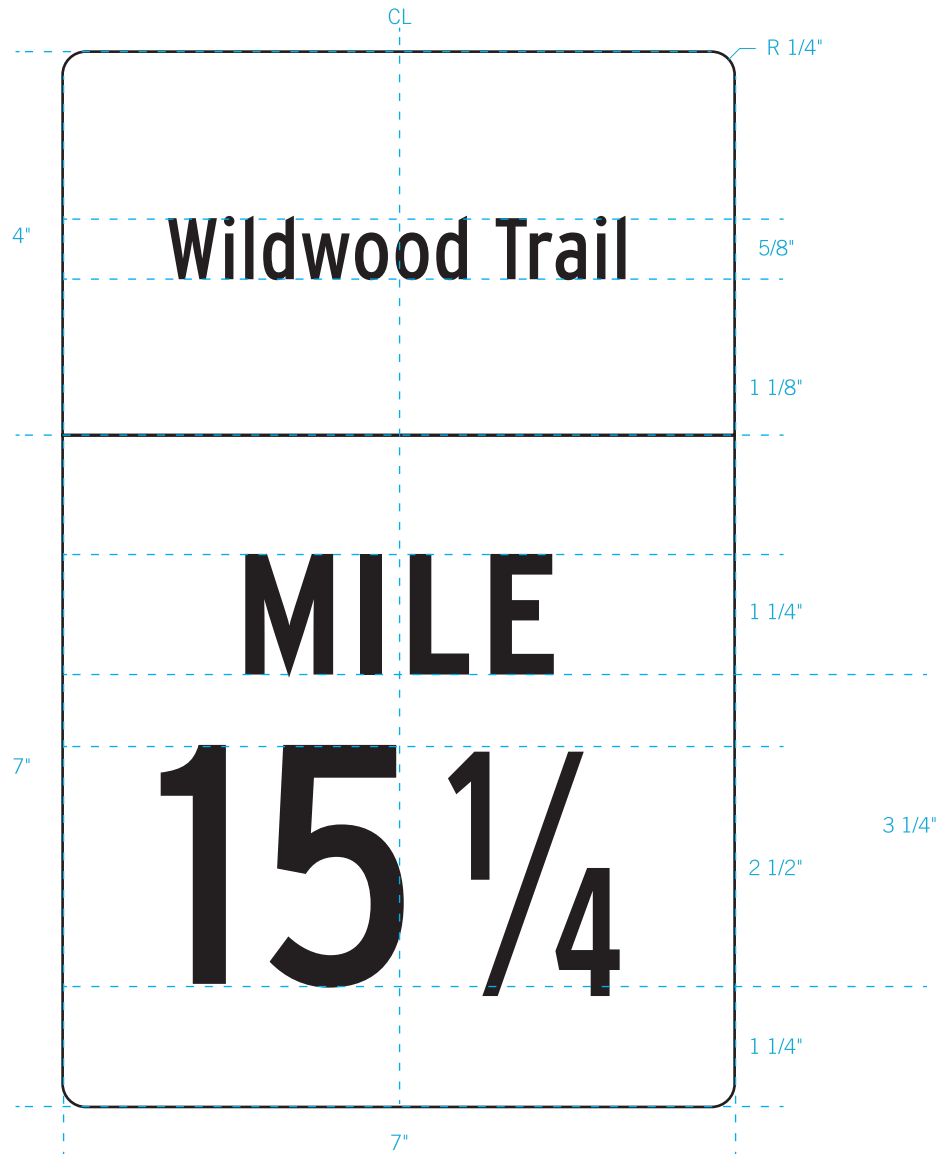

Sign Type E: Layouts

Double Line Header (w/ Mile Message):
Use with mile message layout shown in
Single Line Header w/ Mile Message.

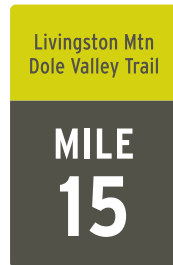

Triple Line Header (w/ Mile Message):
Use with mile message layout shown in
Single Line Header w/ Mile Message.



4.32 Fabrication Details

Sign Type E Layouts

THE INTERTWINE: Regional Trails Signage Guidelines
May 17, 2012

Sign Type E: Layouts

Mile Message Component:

Use to identify the mile along the trail.

Use this component when multiple signs appear on a post. This layout can also be used in conjunction with a Sign Type H of same size with The Intertwine logo.

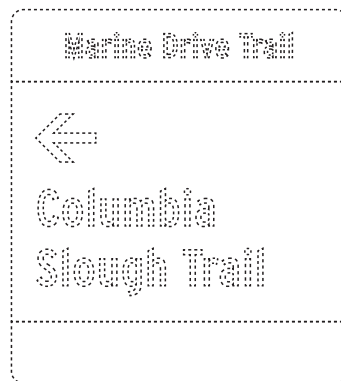
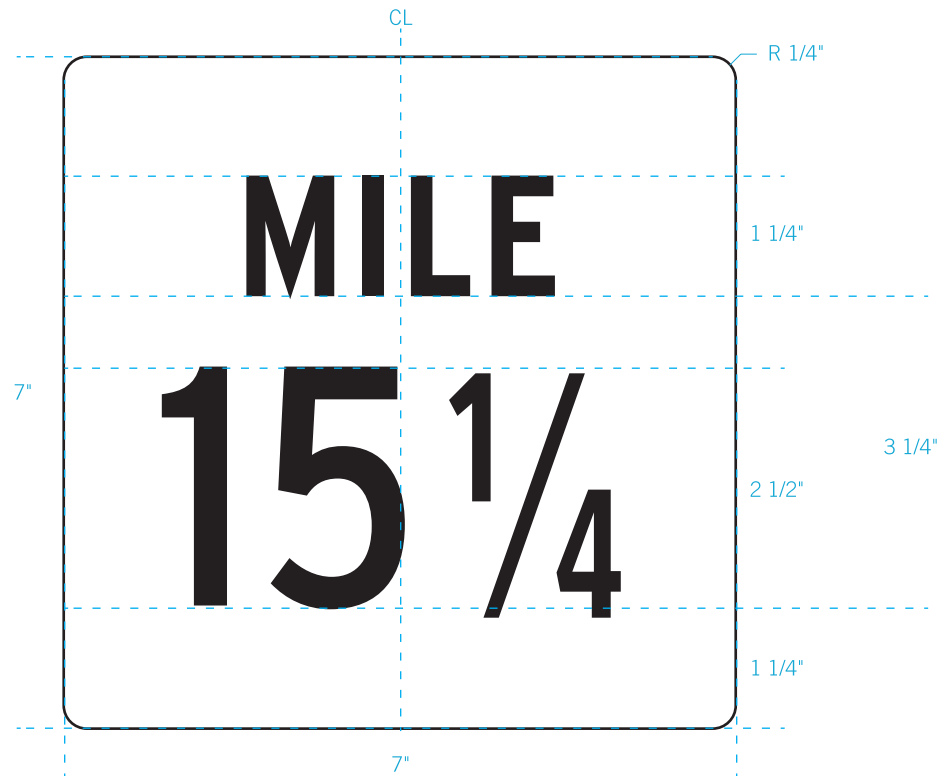

Sign Type F: On-Street Pedestrian Directional Sign Overview

Layouts:

Refer to layout dimensions on the following pages.

Text, logos and symbols are not be located in the Header.

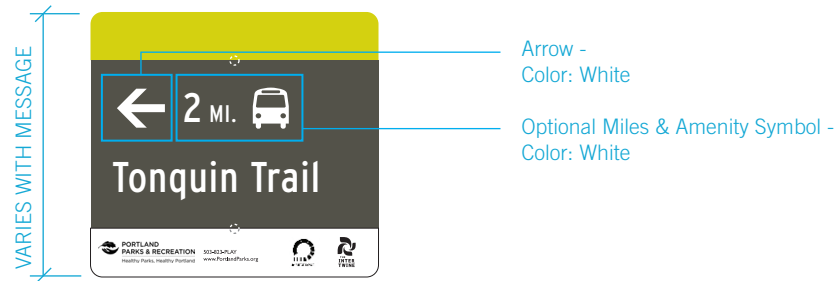
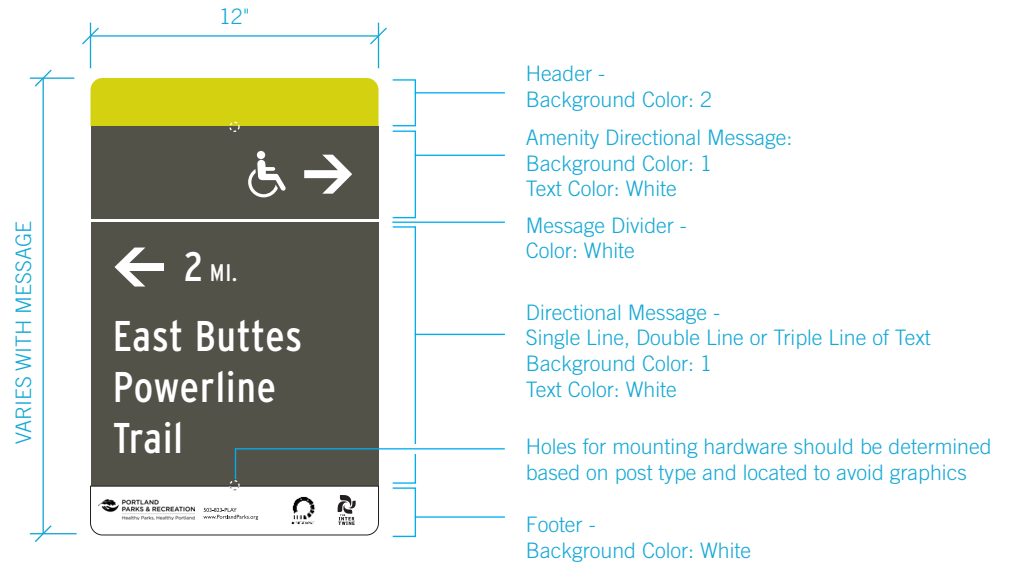

4.34 Fabrication Details

Sign Type F Layouts

THE INTERTWINE: Regional Trails Signage Guidelines
May 17, 2012

Sign Type F: Header Layout

Header:
Use the color band only.

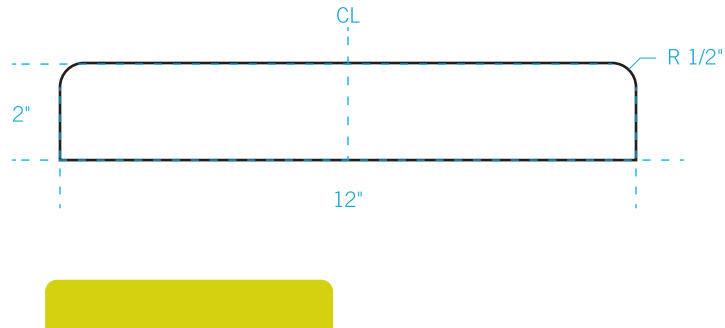

Sign Type F: Directional Layouts

Amenity Directional Message:
Use to direct to an amenity within the immediate vicinity. Use where only a symbol of the amenity will suffice.

Refer to Symbols on page 4.48.

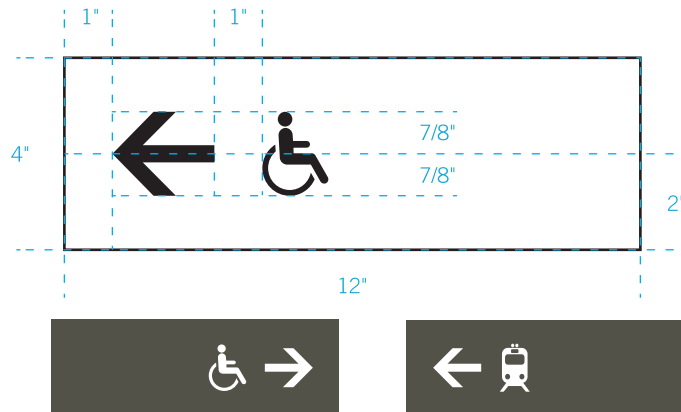

Message Divider:
Use the white divider to separate message layouts.



Do not use adjacent to the Header or the Logo Footer.

Sign Type F: Directional Layouts

Single Line Directional Message:

Use to direct to a destination identified within a single line of text.

Left-justify layout for destinations with a left arrow. Right-justify layout for destinations with a right arrow. (Layout example is shown as left-justified)

Refer to Symbols on page 4.48.

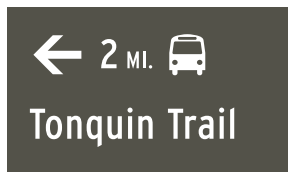
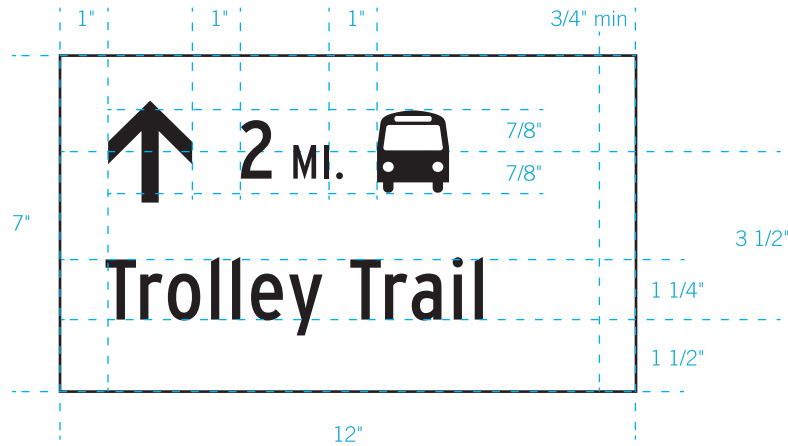

Double Line Directional Message:

Use to direct to a destination identified within two lines of text.

Layout and dimensions can be mirrored to example shown in order to correspond to direction. (i.e. right justified for destinations to the right)

Refer to Symbols on page 4.48.

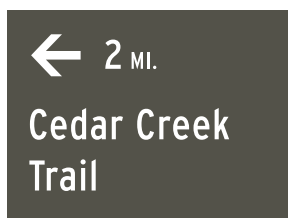
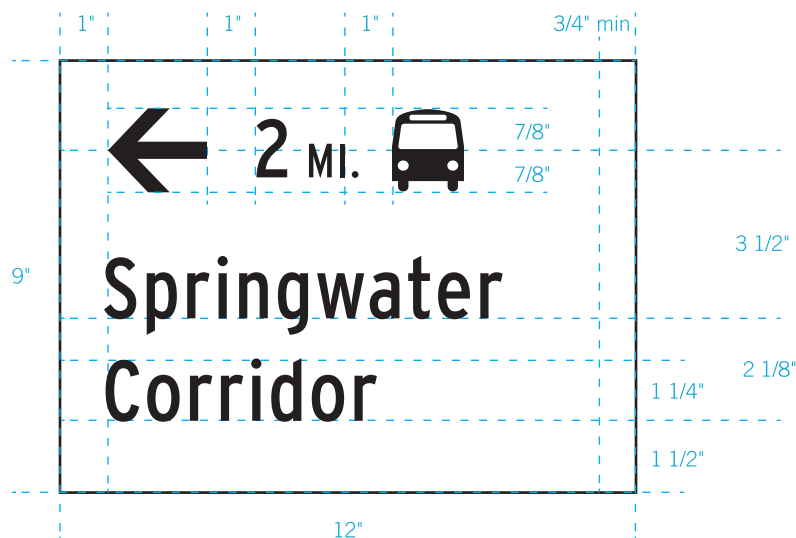

4.36 Fabrication Details

Sign Type F Layouts

Sign Type F: Directional Layouts

Triple Line Directional Message:
Use to direct to a destination identified within three lines of text.

Layout and dimensions can be mirrored to example shown in order to correspond to direction. (i.e. left justified for destinations to the left)

Refer to Symbols on page 4.48.

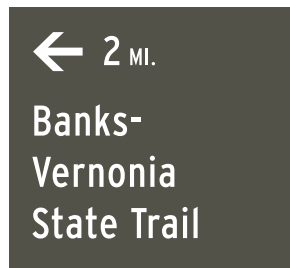
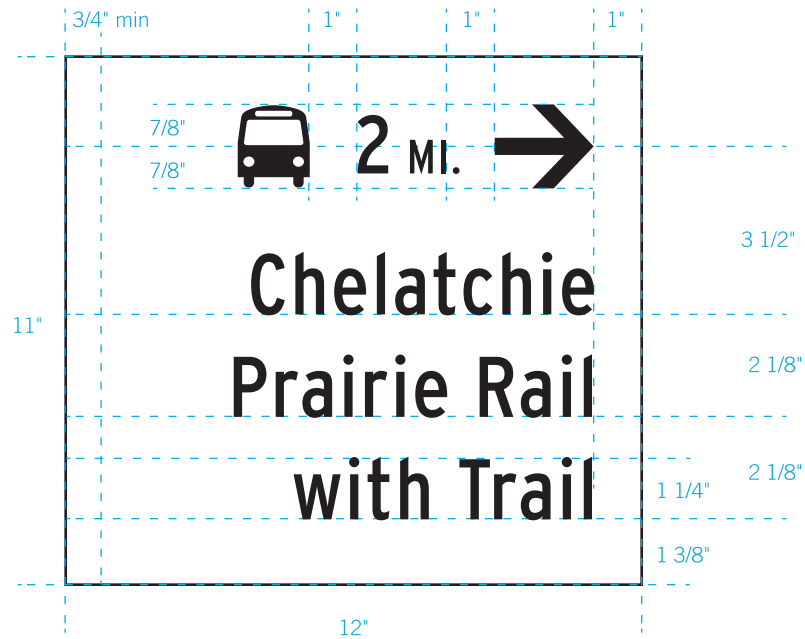

Sign Type F: Directional Layouts

Trail Map:

Trail maps can be used in addition to directionals to support connection information and instructions.

Refer to page 4.50 for trail map artwork guidelines.

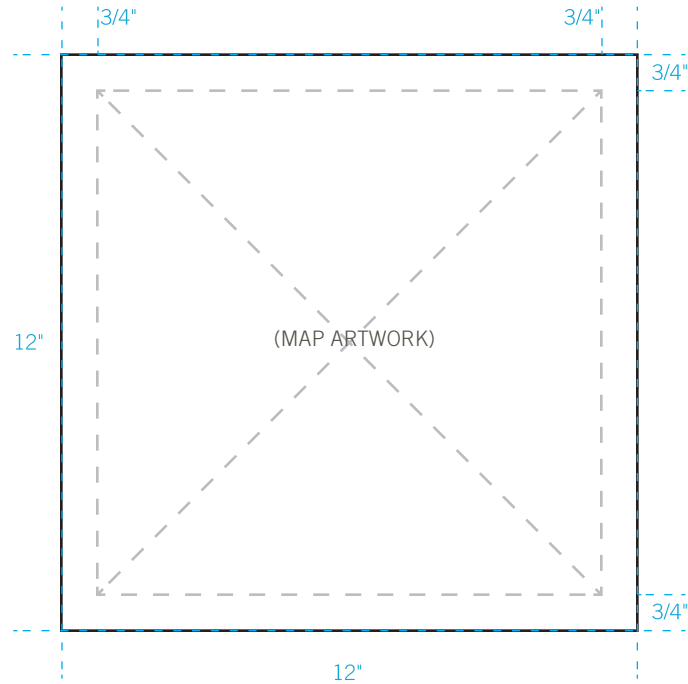

Sign Type F: Logo Footer Layout

Logo Footer:

Use to display the Jurisdiction's logo and contact information, Partner's logo, the Trail or Trail System logo as well as The Intertwine logo.

Refer to Logos on page 4.53.



.....

Sign Type G: On-Street Bicycle Directional Sign Overview

Layouts:

Refer to layout dimensions on the following pages.

Message Guidelines:

Messages on these signs are limited to the regional trail name along with the mileage and minutes and should be located as necessary to direct bicycle traffic to the next off-street trail segment.

Mounting:

These signs are intended to be used as riders under the ODOT Bicycle Signs.

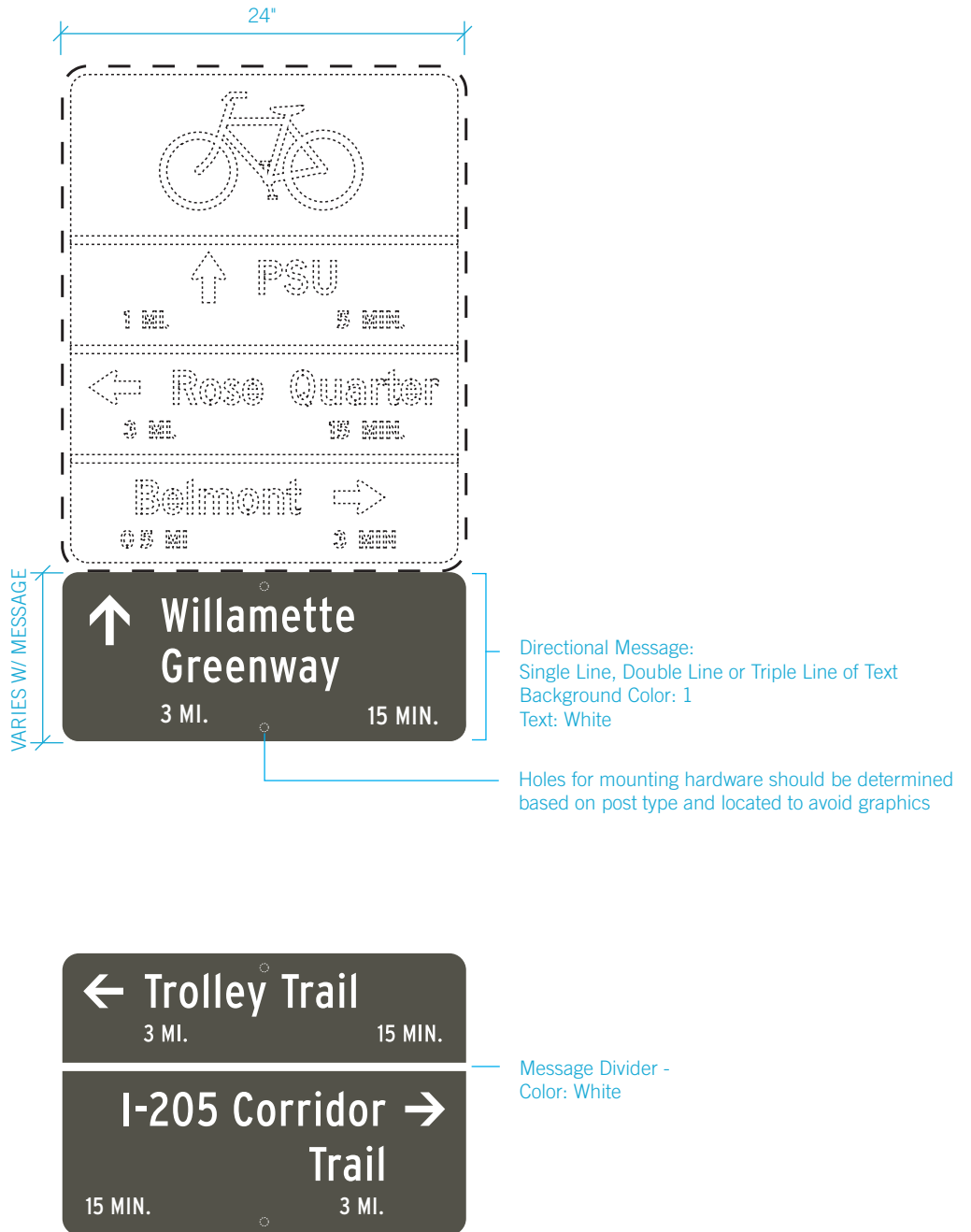

4.40

Fabrication Details

Sign Type G Layouts

Sign Type G: Layouts

Single Line On-Street Rider:
Use to direct to a destination identified within a single line of text.

Left-justify layout for destinations with a left arrow. Right-justify layout for destinations with a right arrow. (Layout example is shown as left-justified)



Double Line On-Street Rider:
Use to direct to a destination identified within two lines of text.

Layout and dimensions can be mirrored to example shown in order to correspond to direction. (i.e. right justified for destinations to the right)

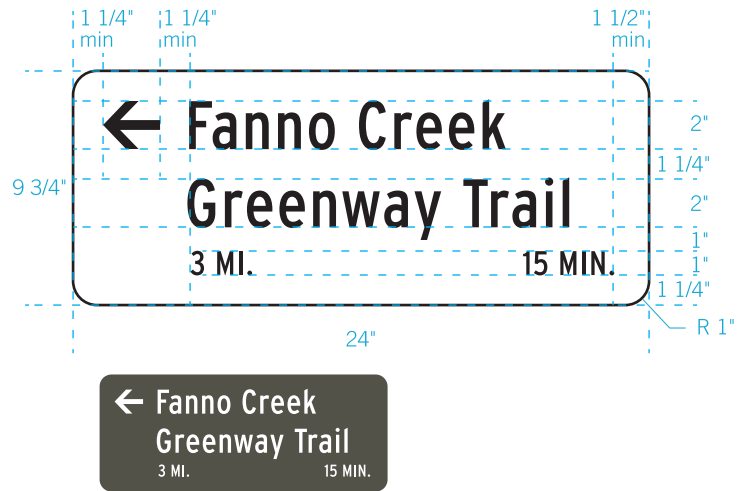

Triple Line On-Street Rider:
Use to direct to a destination identified within three lines of text.

Layout and dimensions can be mirrored to example shown in order to correspond to direction. (i.e. left justified for destinations to the left)



Sign Type G: Layouts

Message Divider:

Use the white divider to separate directional messages if there are multiple directions on one sign panel.

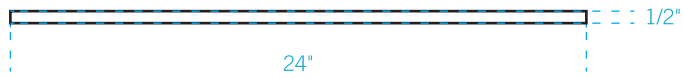

.....

Sign Type H: Intertwine Logo Components Overview

Layouts:

Refer to layout dimensions on the following pages.



H1
Square badge -
.080 aluminum w/ applied vinyl;
or digital print on vinyl



H2
Vertical Badge -
Digital print on vinyl



H4
Sign Post Cap -
.080 aluminum;
can be used with signs
from an existing sign
system or with signs
from these Guidelines



H3
Post Wrap -
Square or round;
digital print on vinyl;
measure and cut to size
before applying



H5
QR Code Component -
(Single or Double Image)



4.44
Fabrication Details

Sign Type H Layouts

Sign Type H: Layouts

H1 Square Intertwine Badge:

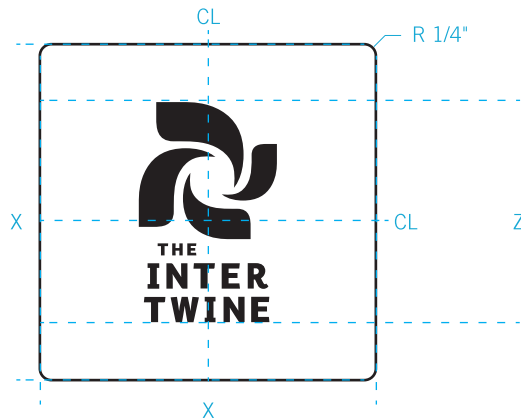

X	Z
6"	4"
7"	4 5/8"
9"	6"
12"	8"

For color specifications, refer to The Intertwine logo on page 4.53.



H2 Rectangular Intertwine Badge:

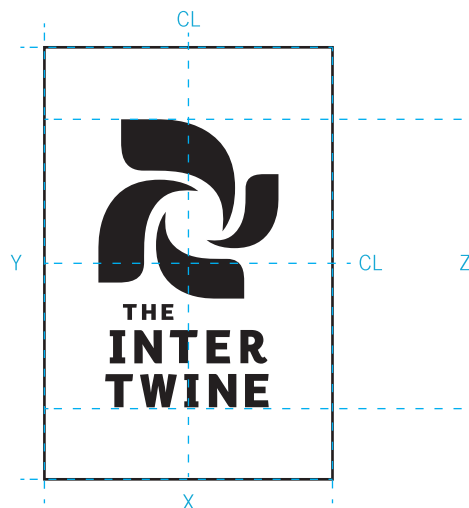

X	Y	Z
2"	3"	2"
3"	4 1/2"	3"
4"	6"	4"
6"	9"	6"

For color specifications, refer to The Intertwine logo on page 4.53.



Sign Type H: Layouts

H3 Sign Post Wrap (Round or Square):

For color specifications, refer to
 The Intertwine logo on page 4.53.

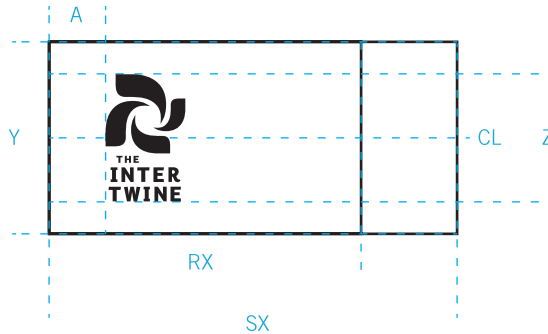

	A	RX	SX	Y	Z
2" Round	1"	6 1/2"	--	4"	2 5/8"
2" Square		--	8 1/2"		
3" Round	1 1/8"	9 1/2"	--	5 1/2"	3 5/8"
3" Square		--	12 1/4"		

**H4 Sign Post Cap
 (Round, Square or U-Channel):**

Logo Panel:
 .080 Aluminum pre-sheated in white
 vinyl; routed corners/shapes

Graphic Imaging:

H4.1 - Translucent Vinyl background
 color 2, Translucent Vinyl Logo color 1.

H4.2 - Translucent Vinyl color 2.

H4.3 - Digital Print on Opaque White
 Vinyl applied to both sides, or Direct
 Print with UV Clear Coat;
 colors 2,3,4 & 5 on white background.
 Refer to color matrix on page 4.52.

Hardware:

Standard Caps with 3.25" flat receiver.
 Available locally through Traffic Safety
 Supply Co. 503.235.8531

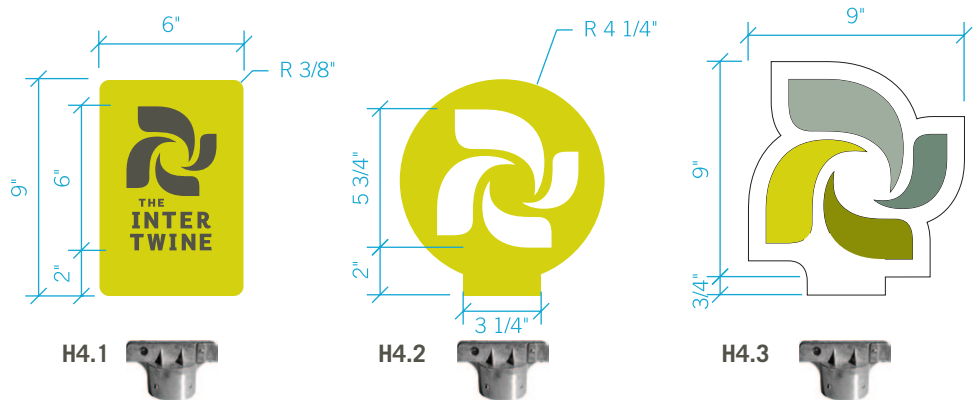

Round Pipe Cap
 2-3/8" Cap
 3.25" receiver
 Flat #16504410

Square Post Cap
 2" Cap
 3.25" receiver
 Flat #16504402

U-Channel Post Cap
 180 Degree Cap
 3.25" receiver
 Flat #16504615

4" Wood Post Cap
 4"X4" Cap
 3.25" receiver
 Flat #16503800

4.46
Fabrication Details

Sign Type H Layouts

Sign Type H: Layouts

H5 QR Code Component (Single):

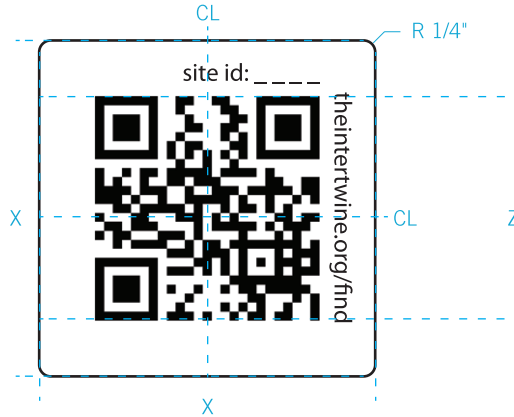

X	Z	TRAIL
3"	2"	Ped-only
6"	4"	Ped & Multi-use
7"	4 5/8"	Ped & Multi-use
12"	8"	Multi-use

H5 QR Code Component (Double):

The 2 panel configuration of this sign type allows an image to be displayed adjacent the QR Code. The image can be an advertisement for your facility featured on The Intertwine website if The Intertwine QR Code is used. The image could also be a sponsor logo with their QR Code or it could be imagery to support a QR Code that is interpretive (i.e. fish cam, wildlife seen along the trail, etc.) The QR Code should be applied to the panel side that is adjacent the trail to enable the user to scan the code with ease.

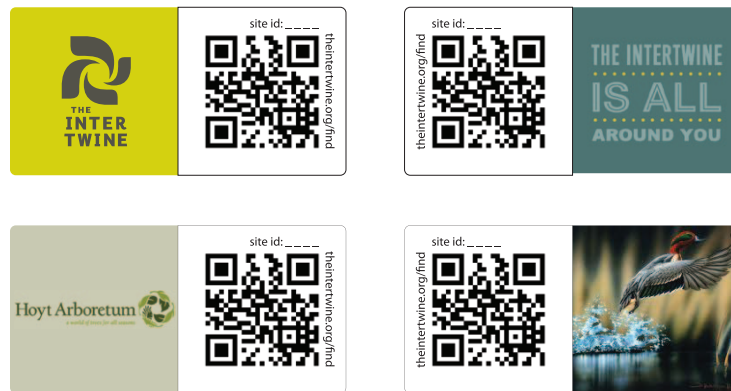
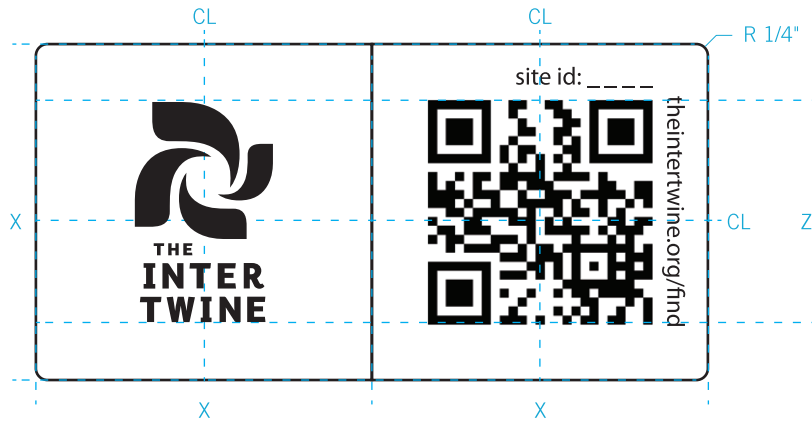

X	Z	TRAIL
3"	2"	Ped-only
6"	4"	Multi-use

Sign Type H: Layouts

The Intertwine QR Code Instructions:

Signs can use this QR Code that will take mobile device browsers to The Intertwine website mobile landing page where visitors will have the option to use a geolocation feature to explore parks around them or to enter a site id number that will take them directly to a specific park or trail webpage.

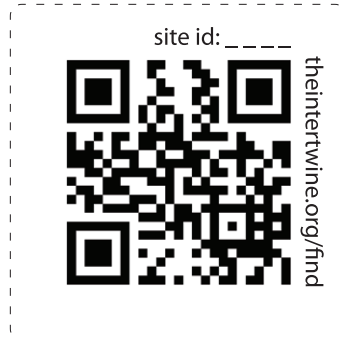

Unique QR Codes that route directly to a specific park or trail page can be generated and made available by The Intertwine.

In addition to the QR Code, signs should display the website's mobile address - theintertwine.org/find - shown in the example as well as the site ID number.

Site ID numbers can be made available for any given park, trail, or natural area by The Intertwine. Staff at The Intertwine will work with sign providers to create robust content for visitors to engage with on a given park or trail page that they are directed to.

The Intertwine QR Code must be displayed in black on a white background. A larger version of this QR code can be downloaded from theintertwine.org/QRcode.

Contact: info@theintertwine.org

4.48
Fabrication Details

Symbols

Symbols

Mode of Travel Symbols:

Use these symbols, typically at trail access points, to indicate the types of use allowed on the trail.

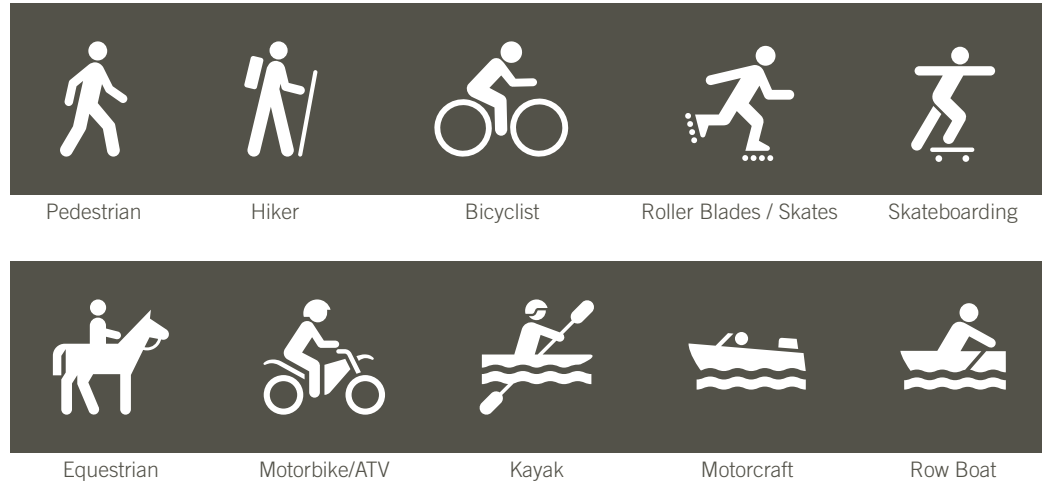

Regulatory Symbols:

Use these symbols, typically at trail access points, to indicate the types of use not allowed on the trail. Regulatory symbols can be used along with or in place of the trail rules and regulations



Transit Symbols:

Use these symbols to direct to a transit stop either in the immediate vicinity or along the route of a destination.



Bus MAX Light Rail Streetcar WES Commuter Rail Aerial Tram

Other Symbols:

Use these symbols to direct to an amenity either in the immediate vicinity or along the route of a destination.



Handicap Accessible Restrooms Crosswalk Pets (On Leash) Information

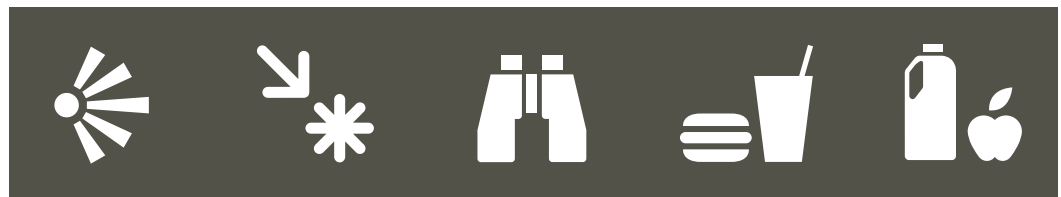

View Point Point of Interest Wildlife Viewing Snacks/Refreshments Store

NOTE:

These universal symbols are taken from the National Park Service pictograph set. Visit www.nps.gov/hfc/map-symbols.htm for the entire symbol listing.



Playground Tennis Courts Baseball Fields Stables Recycling



Swimming Fishing Boat Launch Library Parking



Food / Restaurant Drinking Water Picnic Area Campground

4.50 Fabrication Details

Trail Map

Trail Map

Destinations & Streets:

Destinations should be of regional significance and/or well defined and can include commercial areas, schools, libraries, parks, institutions, other bicycle routes, transit centers and MAX stations. Illustrate destinations with symbols or text. Follow similar guidelines for streets. Include only the streets that define boundaries, destinations or amenities.

Symbols:

Use symbols where possible in the map artwork to show amenities in relationship to the trail.

Use symbols in place of text where possible to illustrate the trail rules and regulations.

Orientation:

The map should always be oriented the "right direction" which is the direction one is facing. When locating these signs, make sure to orient them so that the actual trail and the illustrated trail are "straight ahead". Use a compass as shown to illustrate the cardinal directions.

Include the "You Are Here" at appropriate location.

Map Style:

Use a hierarchy of simplified diagrammatic line quality for a quick read. Although the map should be based on a GIS map, the artwork should be diagrammatic. Simplify lines, intersections and boundaries in order to fit the information in the vertical format.



Left: Sign Type B artwork developed for Fanno Creek Trail in Tigard, oriented in direction of travel on trail.

Below: Google map of Fanno Creek Trail, used as base for artwork (oriented north).

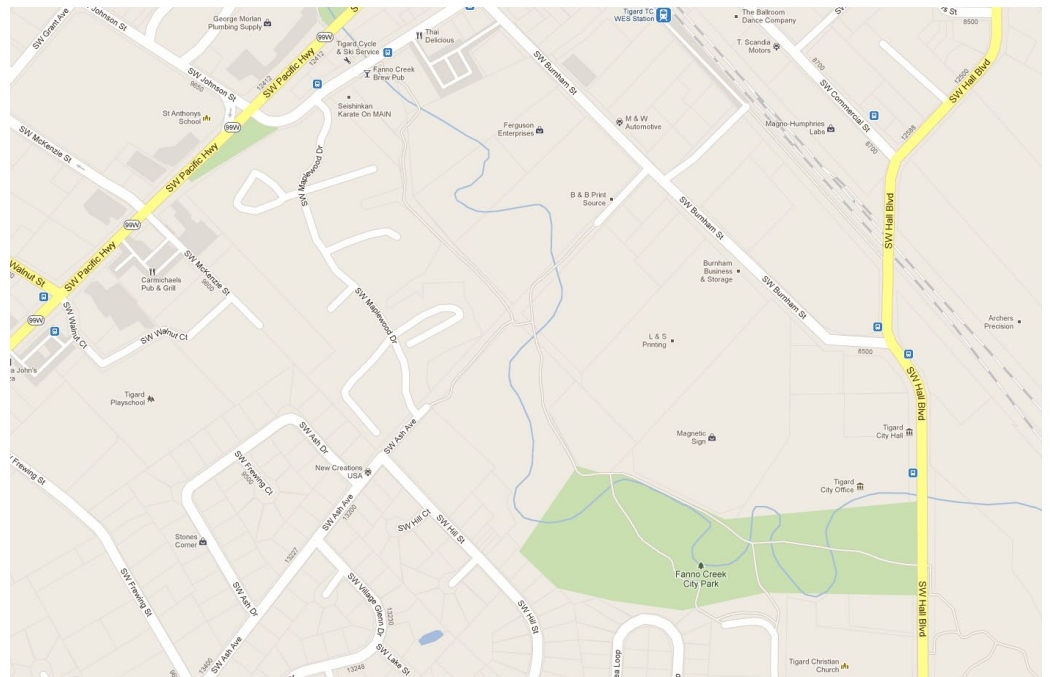

Typography

Font Family 1: Interstate

Based on Federal Highway
Administration (FHWA) font used
in MUTCD.

Interstate Regular Condensed:

Use for all message content

A B C D E F G H I J K L M N O P Q R S T U V W X Y Z
a b c d e f g h i j k l m n o p q r s t u v w x y z
1 2 3 4 5 6 7 8 9 0

Interstate Bold Condensed:

Use for mileage on directional signs

A B C D E F G H I J K L M N O P Q R S T U V W X Y Z
a b c d e f g h i j k l m n o p q r s t u v w x y z
1 2 3 4 5 6 7 8 9 0

Font Family 2: Clearview Hwy

Newly adopted font for Portland
Bicycle Boulevard Signage.

Clearview Hwy 2-W:

If used, use for all message
content.

A B C D E F G H I J K L M N O P Q R S T U V W X Y Z
a b c d e f g h i j k l m n o p q r s t u v w x y z
1 2 3 4 5 6 7 8 9 0

Clearview Hwy 3-W:

If used, use for mileage on
directional signs.

A B C D E F G H I J K L M N O P Q R S T U V W X Y Z
a b c d e f g h i j k l m n o p q r s t u v w x y z
1 2 3 4 5 6 7 8 9 0

Metro has licenses for the above fonts. Jurisdictions can contact Metro to acquire a copy of the font(s)
for The Intertwine Regional Trail Signage layouts.

4.52 Fabrication Details

Colors

THE INTERTWINE: Regional Trails Signage Guidelines
May 17, 2012

Colors

Color Matrix:

This matrix provides color specifications across all materials referenced in these guidelines in order to maintain consistency across all regional trails.

Color	Digital & Direct Print	Translucent Vinyl	Transparent Film
	Trail Maps, Fabrication Method 3	Typical for all Sign Types	Sign Type G Fabrication Method 2
1 Charcoal	Pantone Black 7C 60c 50m 75y 70k	3M & Gerber Duranodic (-69) Oracal 080 Brown	Oracal 073 Dark Grey
2 Grass	Pantone 397C 15c 5m 100y 12k	3M & Gerber Light Lemon Yellow (-115) Oracal 025 Brimstone Yellow	Oracal 025 Brimstone Yellow
3 Sky	Pantone 5635C 35c 9m 20y 20k	--	--
4 Forest	Pantone 582C 35c 10m 100y 38k	--	--
5 Slate	Pantone 5625C 72c 40m 50y 15k	--	--
6 Light Gray	0c 0m 0y 30k	--	--

Logos

The Intertwine Logo:

To maintain a consistent presentation of the brand identity, use the configuration of the icon and type shown below.

To ensure its integrity and visibility, The Intertwine logo should be kept clear of competing text, images and other logos surrounded on all sides by an adequate clear space as shown. There can always be more space surrounding the logo.

When the color version of The Intertwine logo cannot be used, the following versions are available. Please note that The Intertwine logo should not be used in any colors or combinations of colors other than those presented in these standards.

Refer to layouts for **Sign Types H1 & H2** on page 4.44 for various sizing suggestions.

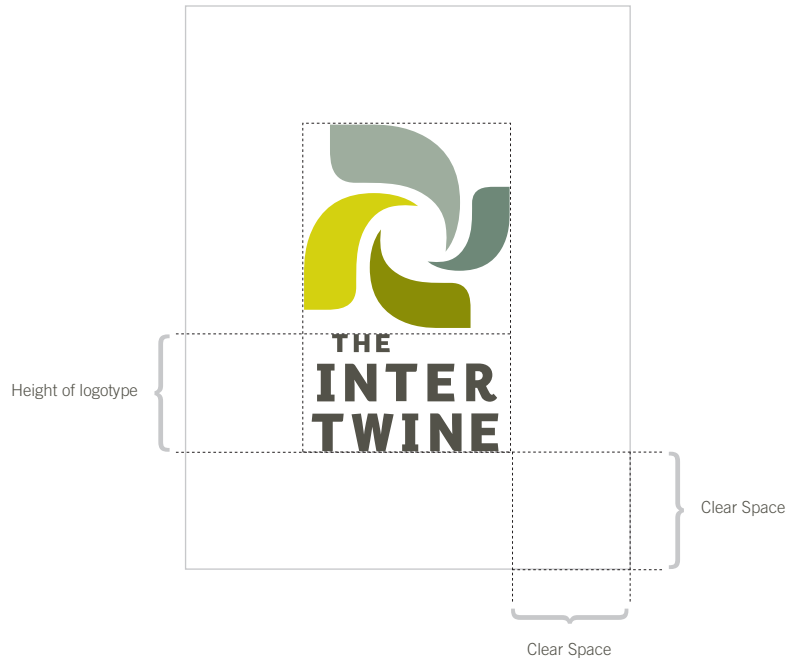

Logo in Colors 1-5
on White Background



Logo in Color 1
on White Background



Logo in Color 1
on Color 2 Background



Logo in White
on Color 1 Background

For color specifications, refer to Color Matrix on page 4.52.

4.54

Fabrication Details

Trail Jurisdiction & Partner Logos

Trail Jurisdiction & Partner Logos:
 Each jurisdiction will be responsible for developing their own layout of the logos and contact information using the layout dimensions of each sign type illustrated in this section. Although the jurisdiction may choose to apply their logo and/or trail logo more prominently than the partner and/or network logos, this grid provides a guideline for the sizing and the placement of multiple logos on the signage, usually in the footer or side bar depending on sign type.

In order to maintain a clean appearance, logos should be displayed in black & white or grayscale as shown.

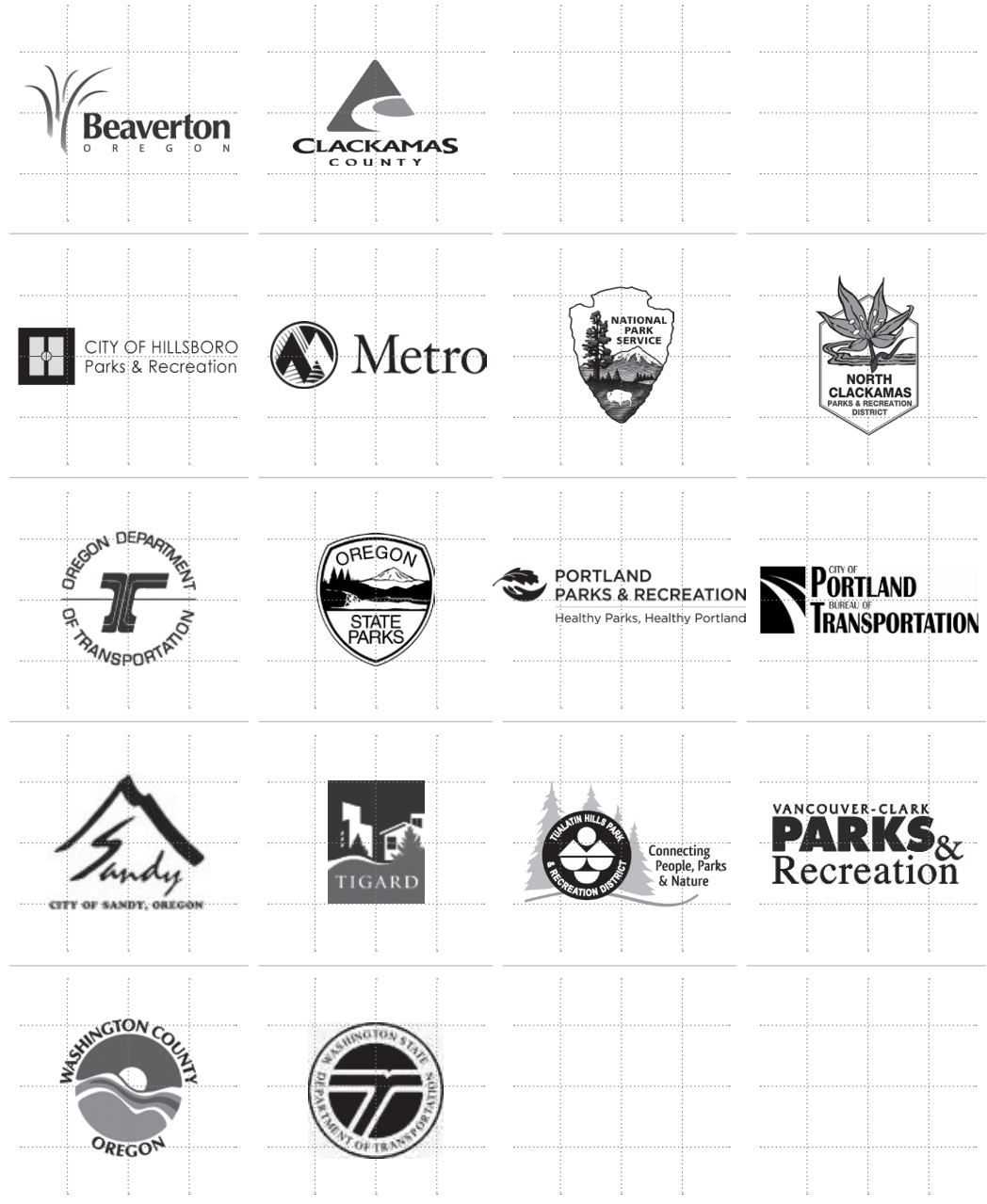

Trail Logos:

These guidelines advise that trail logos appear with the Jurisdiction/ Partner logos, usually in the footer or side bar depending on sign type.

In order to maintain a clean appearance, logos should be displayed in black & white or grayscale as shown.

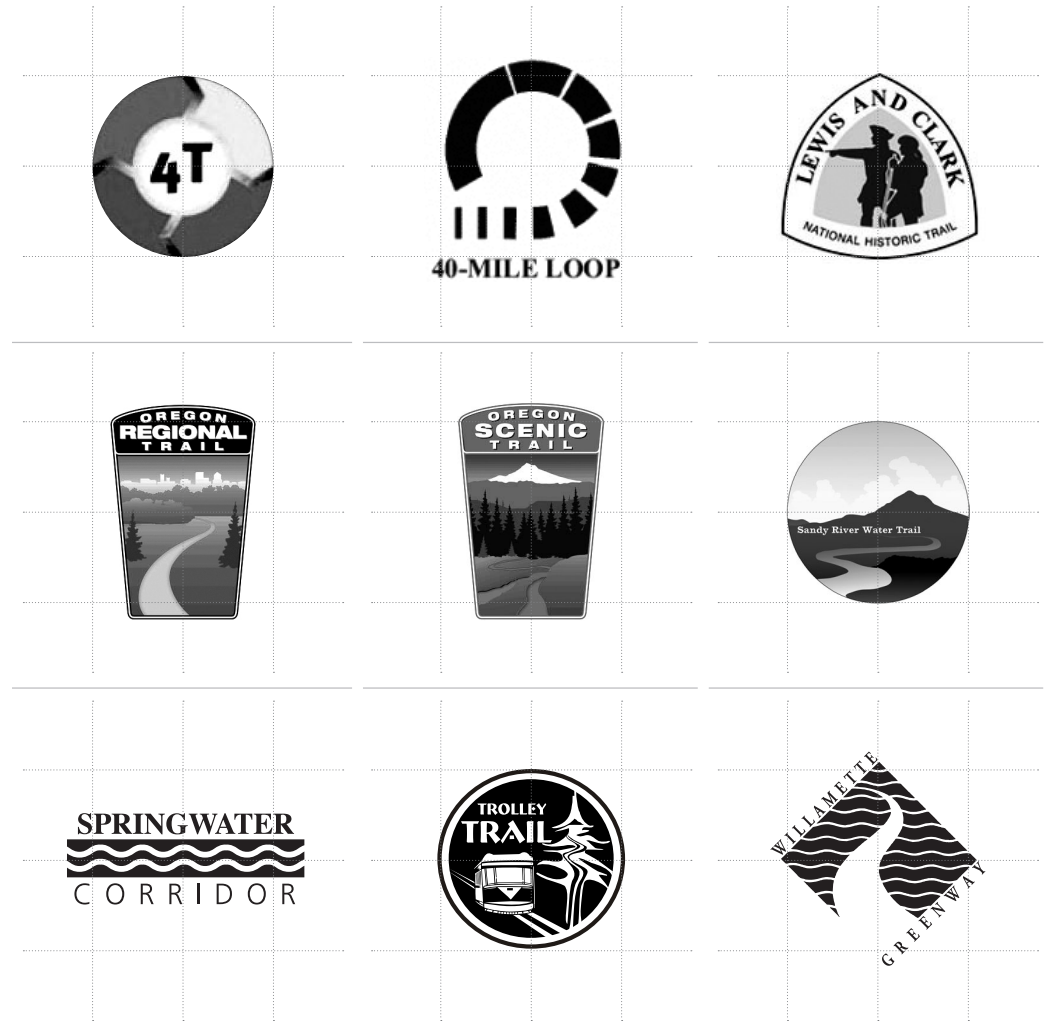

.....

Section 5: Appendix

- 5.02** Regional Trails Map
- 5.03** Regional Trails List
- 5.04** Definitions
- 5.05** Jurisdictional Signage Documents

5.02
Appendix

Regional Trails Map

Regional Trails Map

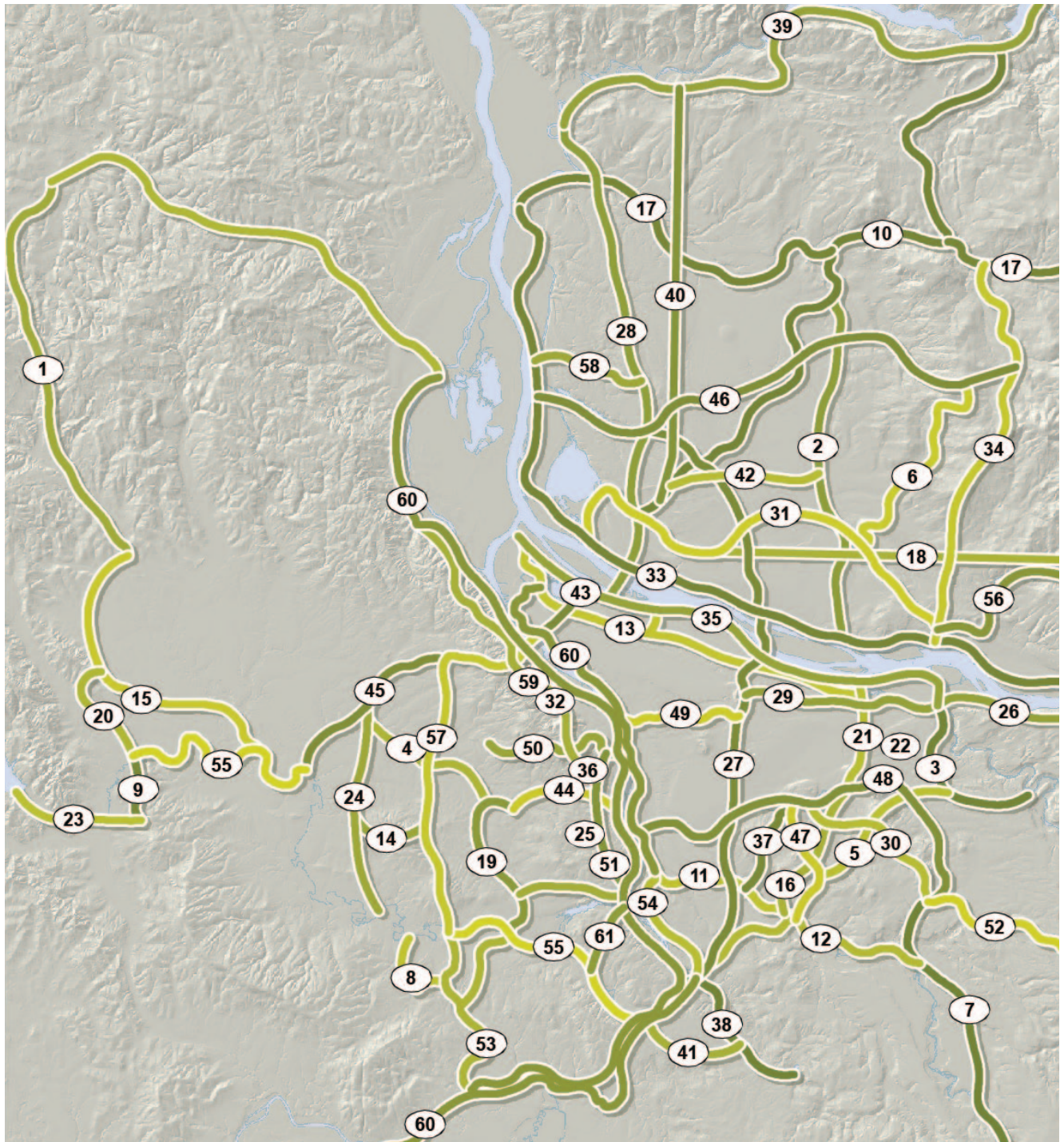



Regional Trails List

Trail names to be confirmed with Metro before fabrication.

1	Banks-Vernonia State Trail	
2	Battle Ground Fisher's Landing Trail	
3	Beaver Creek Trail	
4	Beaverton Creek Trail	
5	Butler Buttes Trail	
6	Camp Bonneville Trail	
7	Cazadero Trail	(50%)
8	Cedar Creek Trail	(25%)
9	Chehalem Ridge Trail	
10	Chelatchie Prairie Trail	(10%)
11	Clackamas Bluffs Trail	
12	Clackamas River Greenway	
13	Columbia Slough Trail	(50%)
14	Cooper Mountain Trail	
15	Council Creek Trail	
16	East Butte Powerline Trail	
17	East Fork Lewis River Trail	
18	East Powerline Trail	
19	Fanno Creek Greenway Trail	(75%)
20	Gales Creek Trail	
21	Gresham-Fairview Trail	
22	Gresham Max Path	
23	Hagg Lake Trail	
24	Hillsboro Powerline Trail	
25	Hillsdale-Lake Oswego Trail	
26	Historic Columbia Highway State Trail	(25%)
27	I-205 Corridor Trail	
28	I-5 Corridor Trail	
29	I-84 Corridor Trail	
30	Kelly Creek Trail	(25%)
31	Lake to Lake Trail	
32	Leif Erikson Trail	
33	Lewis & Clark Greenway	
34	Livingston Mountain Dole Valley Trail	
35	Marine Drive Trail	(75%)
36	Marquam Trail	
37	Mount Scott Trail	
38	Newell Creek Trail	
39	North Fork Lewis River Greenway	
40	North South Powerline Trail	
41	Oregon City Loop Trail	
42	Padden Parkway Trail	
43	Peninsula Crossing Trail	
44	Red Electric Trail	
45	Rock Creek Trail	(50%)
46	Salmon Creek Greenway	
47	Scouter Mountain Trail	
48	Springwater Corridor	
49	Sullivan's Gulch Trail	
50	Sunset Highway Trail	
51	Terwilliger Trail	
52	Tickle Creek Trail	(25%)
53	Tonquin Trail	(25%)
54	Trolley Trail	
55	Tualatin River Greenway	(25%)
56	Washougal River Corridor Trail	
57	Westside Trail	(50%)
58	Whipple Creek Greenway	
59	Wildwood Trail	
60	Willamette Greenway	(50%)
61	Wilson Creek Trail	

Trail Status as of 2012

	Completed
	Under Construction (Percent Complete)
	Proposed

Definitions

The following are some of the typical terms used in conjunction with this document.

Corridor, Trail

The full dimensions of a route, including the tread and a zone on either side (usually three feet) and above the tread from which the brush will be removed.

Greenway

A linear open space established along a natural corridor, such as a river, stream, ridgeline, rail-trail, canal, or other route for conservation, recreation, or alternative transportation purposes. Greenways can connect parks, nature preserves, cultural facilities and historic sites with business and residential areas.

Loop Trails

Trail systems that form loops, giving users the option of not traveling the same section of trail more than once a trip.

Regional Trails †

Trails that connect across jurisdictions, are primarily off-street, and typically multi-modal. “Regional” is highest classification in a trail hierarchy that also includes “community” and “local” trails.

Trail

Linear route on land or water with protected status and public access for recreation or transportation purposes such as walking, jogging, motorcycling, hiking, bicycling, ATVing, horseback riding, mountain biking, canoeing, kayaking, and backpacking.

Trailhead

An access point to a trail often accompanied by various public facilities, parking areas, toilets, water, directional and informational signs.

<http://www.americantrails.org/resources/info/glossary.html>

† Metro

modified 02/01/12

Jurisdictional Signage Documents

40-Mile Loop Signing Guidelines

City of Sandy Park & Trail Signage

City of Gresham Trail Signage Guidelines

City of Gresham Bike Signage

Metro Sign Manual

MUTCD

Oregon Parks & Rec. Signage Guidelines

PBOT Bike Signage

Portland Parks & Rec Signage Standards

The Intertwine Branding Signage Manual

Tualatin Hills Park & Rec. Signage Guidelines

Vancouver, Washington Phase 1: Bike Trail Signing Plan