

Sintered Slabs.
Merchandising



AETERNA
anatolia

Marketing support, *Table Top Display*

Aeterna's collection of Sintered Slabs are brought to life in a table top display that can hold up to 62 stunning sample chips. Each sample chip features an affixed label showing pertinent information like the full slab design, size, thickness, and finish availability as well as a QR code that links to the website for more details. The sample chips have been carefully designed and cut to be truly representative of the color, vein, and graphical experience of the full size slab. The table top display is elegantly showcased on a black wooden inspiration base with a sleek branding fixture that introduces the collection. Great care has been taken to maximize display space efficiency while providing the most motivating presentation of the collection.

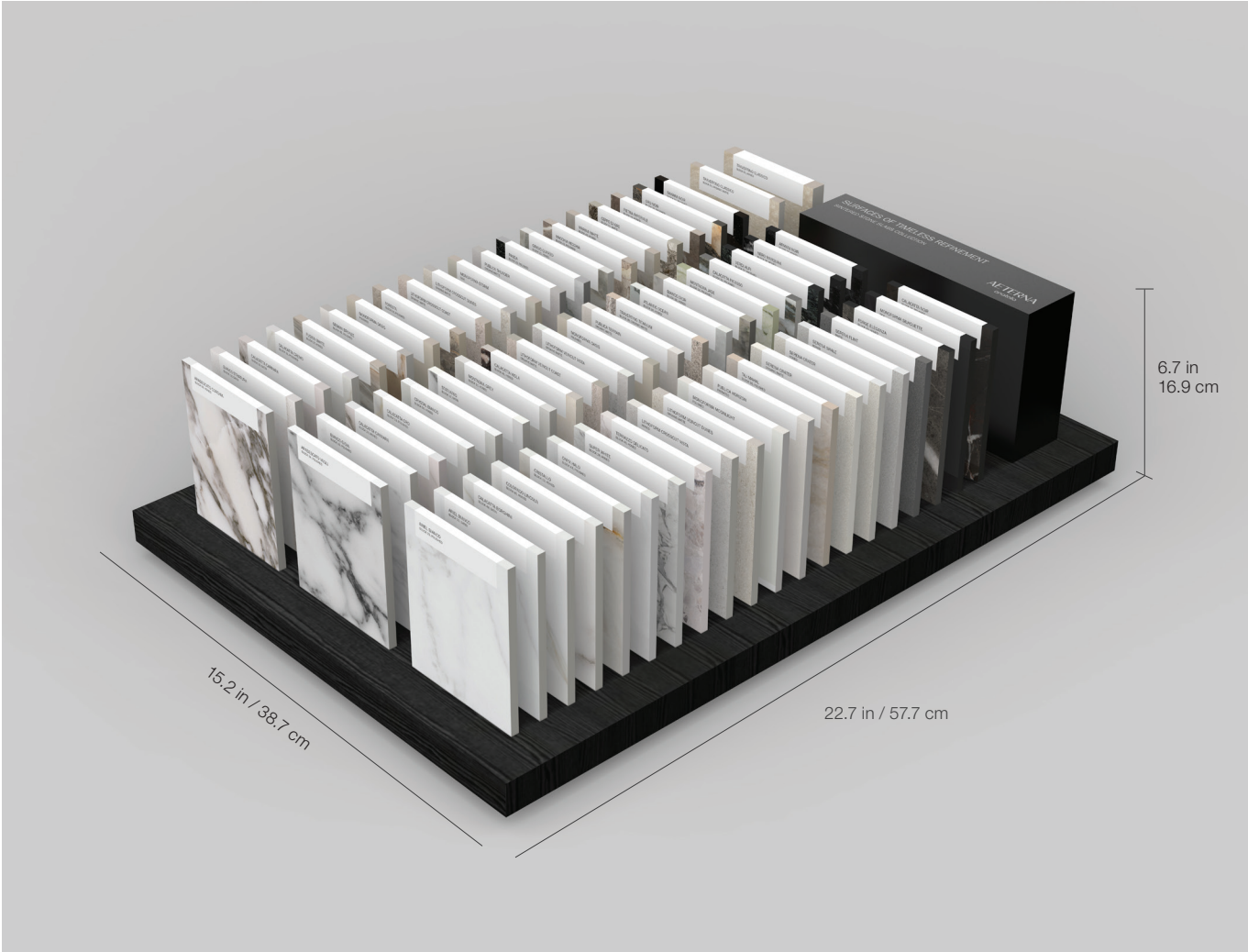

Marketing support, *A&D Binder*

In today's fast-paced A&D community and dealer network, space within design libraries and showrooms is often limited. To address this challenge, we have crafted an elegant and highly efficient solution: Aeterna's A&D binders. Each binder is thoughtfully designed to provide both functionality and sophistication. The front cover introduces the collection with key information and a stunning render. Upon opening, the binder reveals up to 12 sintered sample chips, showcasing the breath of Aeterna's exquisite collection. The sample chips have been carefully designed and cut to be truly representative of the color, vein, and graphical experience of the full size slab. Available in 12 distinct editions, each binder highlights a curated selection of sintered slabs. Designed with precision, the binder features a spine that clearly identifies the collection name and material type, allowing for easy access and organization. This binder is an essential tool that merges convenience with luxury, elevating your design experience.



A&D Binder Outside



A&D Binder Inside

A&D Binder at a glance

Fully Open:
30 in / 76.7 cm

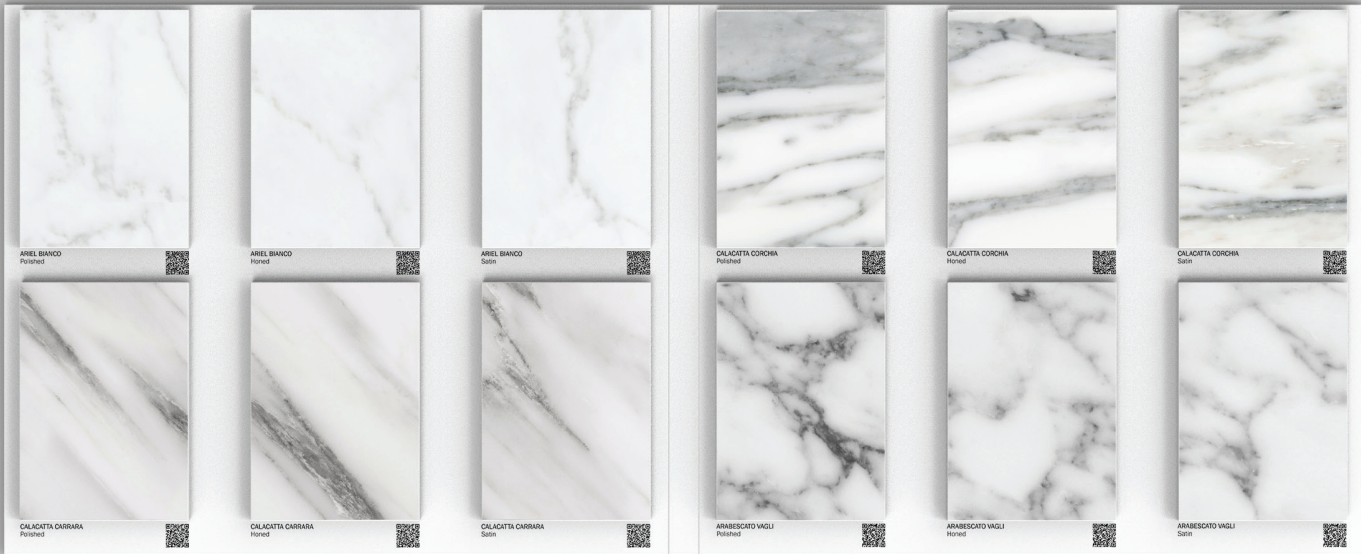

12.2 in
31 cm

14.8 in / 37.5 cm

Marketing support, *Sample Chips*

Sample chips are an essential tool for bringing mood boards to life and creating a cohesive design vision. The compact 4 x 5 in / 9.5 x 13.4 cm sample chip is thoughtfully designed for portability and precision, making it ideal for quick comparisons and seamless integration into design presentations. This versatile chip is also featured in the Sintered Slab A&D Binder, Tabletop Display, and Sample Chip Box, all available in a sleek 6 mm thickness.

Aeterna has created a sample chip program featuring every color and finish combination that includes key information and a QR code to discover more information for that color on its back label. The sample chips have been carefully designed and cut to be truly representative of the color, vein, and graphical experience of the full size slab. Aeterna also developed a premium sample chip carrying case to easily and beautifully store, organize, and carry sample chips to meetings.

Aeterna's sintered slab sample chips have been designed with a new label that wraps around the top edge of the sample chip, allowing for a clean, modern aesthetic.



Sample Chip Size: 4 x 5 in / 9.5 x 13.4 cm

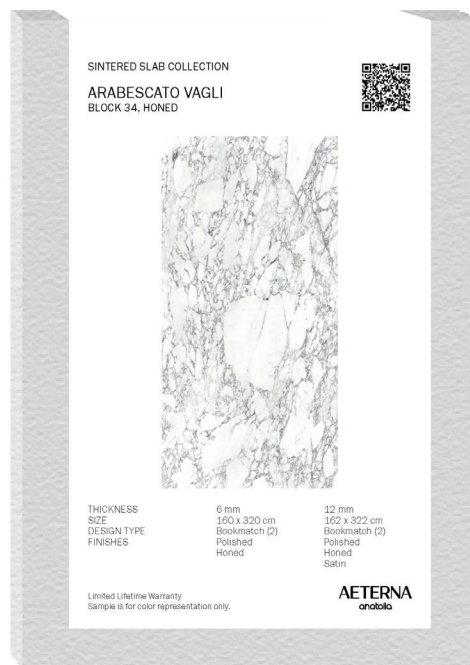

THICKNESS	6 mm	12 mm
SIZE	160 x 320 cm	162 x 322 cm
DESIGN TYPE	Bookmatch (2)	Bookmatch (2)
FINISHES	Polished Honed	Polished Honed Satin

Limited Lifetime Warranty
Sample is for color representation only.

AETERNA
anato

Ordering Options:

1. Custom Selection

Personalize your sample chip selection for a unique range. This option does not arrange the selection into specific boxes.

2. Pre-Determined Sets

Choose from Aeterna's two carefully curated and pre-determined sets, each containing sample chips in a variety of colors and finishes. The exact assortment of these pre-determined sets can be retrieved from your Business Development Manager.

Set 1: 30 x 6 mm + 1 x 12mm

Set 2: 30 x 6 mm

3. Custom Selection Sets

Create your own custom set choosing from one of the two options with a personalized selection of sample chips. An order of 32 identical sets is required, each arranged and packaged together in separate boxes.

Option 1: 30 x 6 mm + 1 x 12mm

Option 2: 32 x 6 mm

Marketing support, *Sample Program*

Samples are key to visualizing and refining design concepts, helping to create a unified aesthetic. The A-shape 12 x 12 in / 30 x 30 cm sample offers a slightly larger surface, making it ideal for showcasing intricate material details, veining, and texture, while still being easy to maneuver and manage. This 12 mm A-shape sample is a premium selection designed for display in Aeterna's Gallery Tower Displays, offering a striking presentation of material and design.

Aeterna has created a sample program that includes key information and a QR code to discover more information for that color on its back label.

Sintered slab samples have been designed with a new label that wraps around the top edge of the sample, allowing for a clean, modern aesthetic.



Sample Size: 12 x 12 in / 30 x 30 cm

Ordering Options:

1. Custom Selection

Personalize your sample selection for a unique range. This option does not arrange the selection into specific boxes.

2. Custom Selection Sets

Create custom sets with a personalized selection of 10 samples. A minimum order of 10 identical sets is required, each arranged and packaged together in separate boxes.

Marketing support, *Sample Program*

Aeterna's sample program is offered in a refined 9 x 12 in / 22.5 x 30 cm size, expertly crafted to provide an impeccable balance of detail and portability. This versatile 12 mm sample elegantly captures the intricate textures, veining, and color variations of our exclusive collections, making it the ideal choice for a professional presentation within the Gallery Tower Display or alone. The thoughtfully proportioned dimensions ensure that each design element is showcased with precision, offering a sophisticated solution for any showroom.

Aeterna's innovative sample program includes essential information and a QR code on the back label, providing easy access to further details about each color. Designed with a modern aesthetic in mind, maintaining a clean and contemporary look.

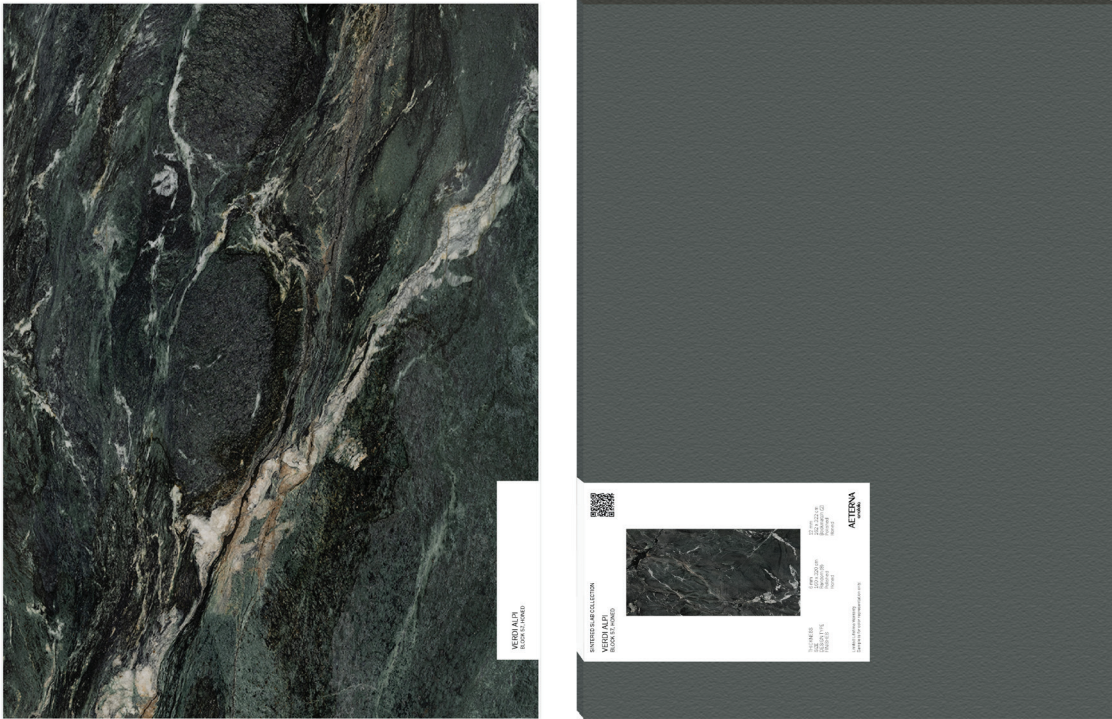

Sample Size: 9 x 12 in / 22.5 x 30 cm

Ordering Options:

1. Custom Selection

Personalize your sample selection for a unique range. This option does not arrange the selection into specific boxes.

2. Custom Selection Sets

Create custom sets with a personalized selection of 10 samples. A minimum order of 10 identical sets is required, each arranged and packaged together in separate boxes.

Marketing support, *Sample Program*

Aeterna's sample program is offered in a novel A-shape in a 24 x 24 in / 60 x 60 cm size, expertly crafted to provide an impeccable balance of detail and portability. This 12 mm versatile sample elegantly captures the intricate textures, veining, and color variations of our exclusive collections, making it the ideal choice for a professional presentation. The thoughtfully proportioned dimensions ensure that each design element is showcased with precision, offering a sophisticated solution for any showroom.

Aeterna's innovative sample program includes essential information and a QR code on the back label, providing easy access to further details about each color. Designed with a modern aesthetic in mind, maintaining a clean and contemporary look.



Sample Size: 24 x 24 in / 60 x 60 cm

Marketing support, *Sample Chip Carrying Case*

Aeterna proudly presents our premium sample chip carrying case, designed to elevate the way you store, organize, and transport your sintered slab sample chips. Crafted with both elegance and practicality in mind, this sleek carrying case offers the perfect solution for keeping your sample chips organized and easily accessible for meetings, presentations, or showroom displays. The case, which comes empty, is designed to comfortably hold up to 30 6mm and one 12 mm sample chips, allowing you to showcase a curated selection of Aeterna's stunning materials in two different thickness, ensuring maximum color variety. The sample selection is fully customizable to suit your design preferences and needs. Whether you're on the go or storing samples in your library, this luxurious case ensures your collection is both beautifully presented and effortlessly portable—making it an essential tool for any design professional seeking to impress.

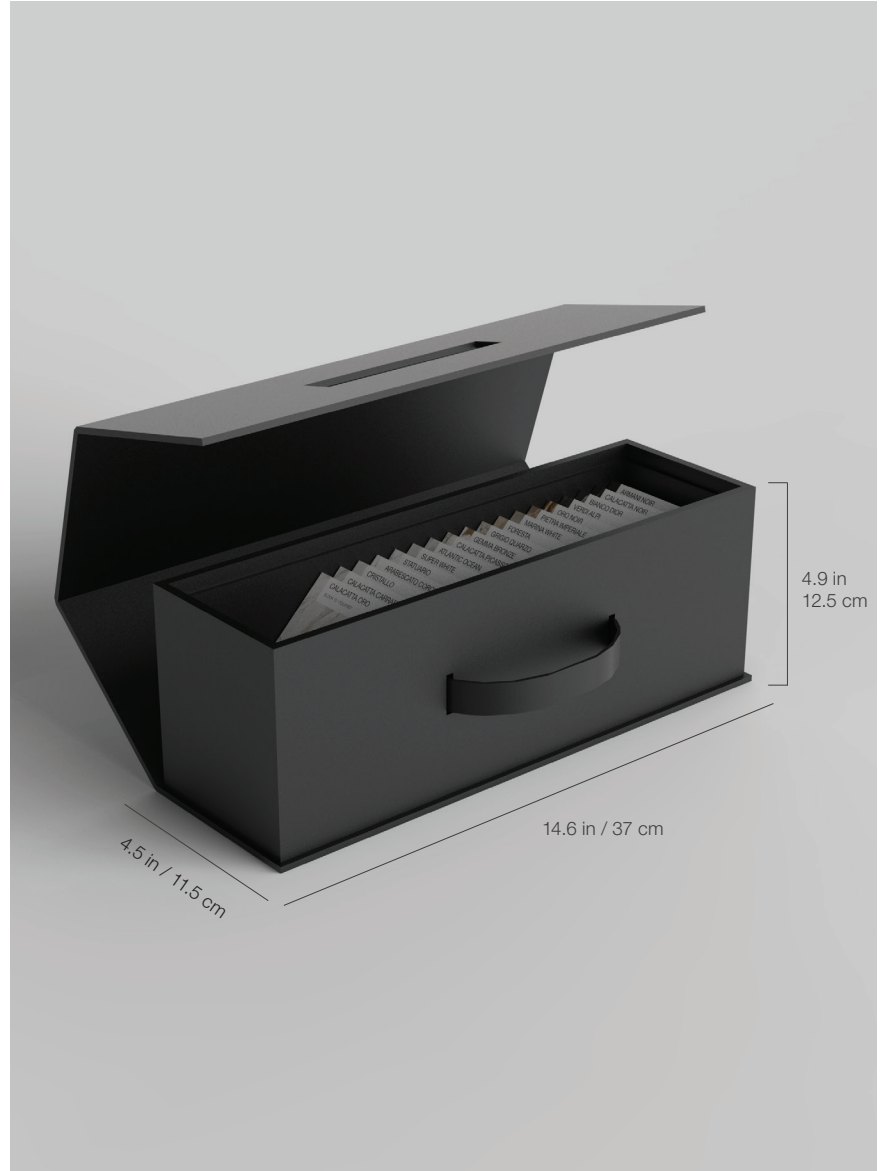

Marketing support, *Gallery Tower Display - 75 PC*

The Gallery Tower Display balances sophistication and practicality. Fully customizable, it showcases 75 samples from our exclusive collections. With clean lines and a wood-look finish, this display offers a polished, professional presentation, efficiently highlighting product details and color options from our premium range.

The Gallery Tower Display is an elegant and versatile solution, designed to feature two distinct 12 mm sample options to best showcase Aeterna's exceptional designs. Choose between the 12 x 12 in / 30 x 30 cm A-shape samples or the 9 x 12 in / 22.5 x 30 cm rectangular samples, each providing a tailored presentation to highlight the unique qualities of our collections.



Gallery Tower Display at a glance



Gallery Tower Display with 12 x 12 in / 30 x 30 cm A-shape samples

Gallery Tower Display at a glance



Gallery Tower Display with 9 x 12 in / 22.5 x 30 cm rectangular samples



Gallery Tower Display 75-Piece Set

Marketing support, *Gallery Tower Display - 30 PC*

The Gallery Tower Display strikes the perfect balance between sophistication and practicality, and is also available in a compact version for enhanced versatility in your showroom. Fully customizable, it elegantly showcases 30 samples from our exclusive collections. Featuring clean lines and a refined wood-look finish, this display offers a polished, professional presentation while efficiently highlighting key product details and color options. The compact design makes it ideal for maximizing showroom space, ensuring that your premium range is presented with style and ease, while maintaining accessibility for your clients.

The Gallery Tower Display is an elegant and versatile solution, designed to feature two distinct 12 mm sample options to best showcase Aeterna's exceptional designs. Choose between the 12 x 12 in / 30 x 30 cm A-shape samples or the 9 x 12 in / 22.5 x 30 cm rectangular samples, each providing a tailored presentation to highlight the unique qualities of our collections.



Gallery Tower Display at a glance



Gallery Tower Display with 12 x 12 in / 30 x 30 cm A-shape samples

Gallery Tower Display at a glance



Gallery Tower Display with 9 x 12 in / 22.5 x 30 cm rectangular samples



Gallery Tower Display 30-Piece Set

Marketing support, *Showroom Display Fixtures*

This customizable standing display structure showcases the essence of Aeterna's sintered slab collection in an elegant presentation. The structure is designed to allow a selection of a custom assortment of sintered slabs to exhibit. Each curated fixture highlights the intricate designs and colors offered in the collection and includes an information panel that provides more details alongside a meticulously crafted room scene. The display also incorporates a tailored lighting system designed to highlight the collection in the most flattering manner. We provide details and instructions for you to directly manage the installation in your showroom.



Showroom Display Fixtures at a glance

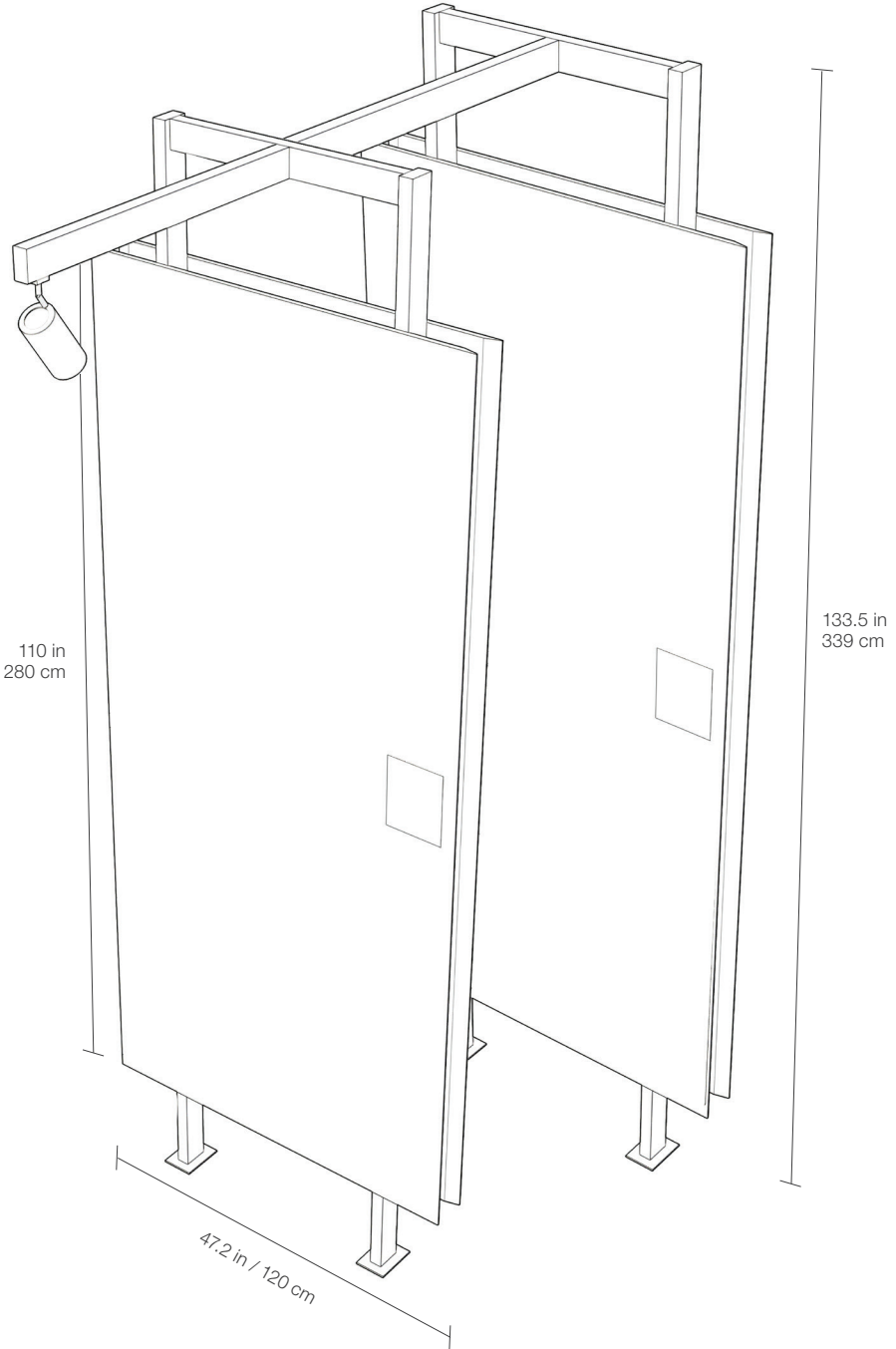

Marketing support, *Showroom Waterfall Display*

Maximize your showroom's potential with our innovative modular sintered slab display. Designed with a sleek, angled configuration, this display allows you to present a wider variety of slabs in either 6mm or 12mm thickness in a compact footprint by featuring the sintered slabs cut at a smaller width. Ideal for spaces with limited room, it offers versatile placement options, whether against a wall or as a central island, with slabs showcased on both sides. Enhance both the aesthetics and functionality of your showroom while providing clients with an expanded selection of Aeterna's premium surfaces, all in a beautifully organized and space-efficient manner.



Marketing support, *Showroom Waterfall Wall Display*

Available in a 3-piece modular set, this display's angled design reduces its width, allowing you to showcase a broader selection of 6 mm and 12 mm slabs without compromising on space. Perfect for tight showroom layouts, the wall configuration optimizes surface area while keeping your premium slabs organized and easily accessible for clients. Its sleek design elevates both the aesthetics and functionality of your display, making it a smart, space-efficient solution.



Marketing support, *Showroom Waterfall Standing Display*

For a more dynamic presentation, Aeterna's standing sintered slab display offers the same modular flexibility in a central island setup. With the option to feature slabs on both sides, this display is available in either a 3-piece or 6-piece set, allowing you to scale according to your showroom's needs. The angled design not only saves space but also enhances the visibility of your entire slab collection, offering clients a convenient and engaging shopping experience. This versatile display transforms any showroom into a modern, efficient space, balancing form and function.

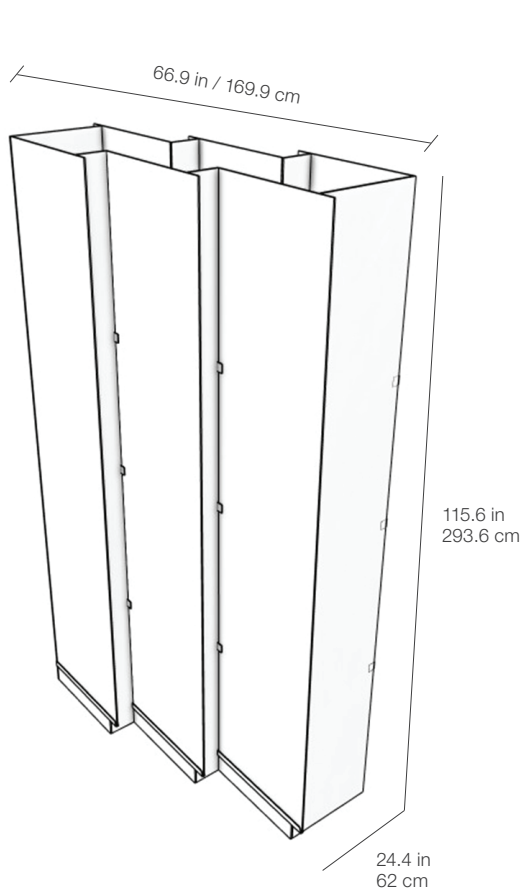

Showroom Waterfall Standing Display 3-Piece Set

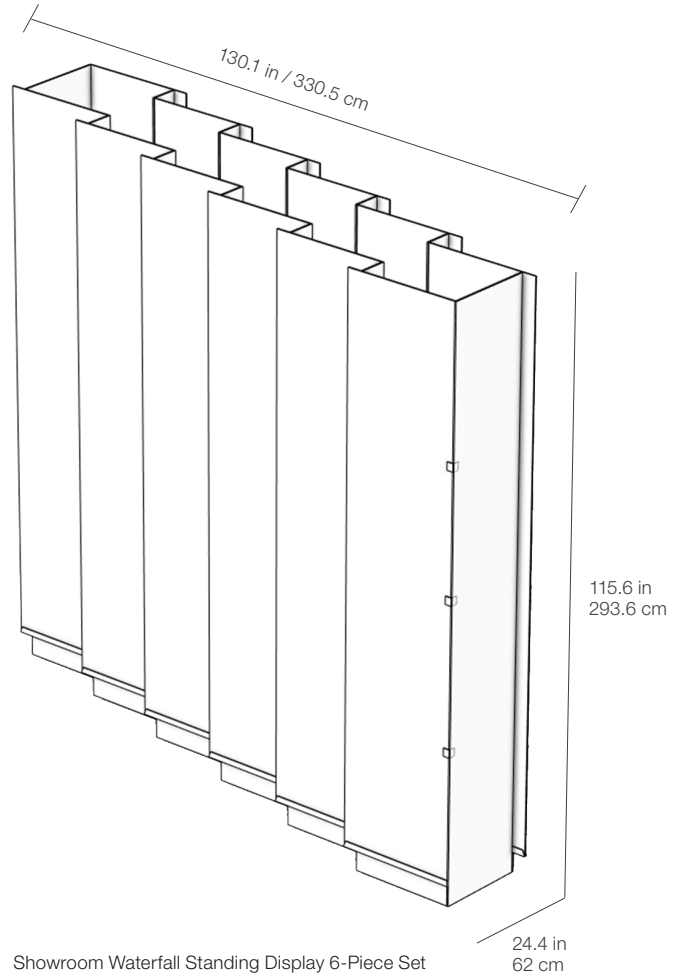

Showroom Waterfall Standing Display 6-Piece Set