



SX1

Single Axle Side Dump Trailer



20' to 30' frame lengths ▶ Stockpile or windrow ◀ Watertight; no leaks ▶ Low load height

800-779-8099 • 712-546-4409 • sidedump.com

Single Axle Side Dump
SX1



SX1

Single Axle Side Dump Trailer

Model SX1-2317 SmithCo Side Dump Trailer with CD-1 Dolly

Specs shown are for 22'2" frame length; other configurations available.

Frame Length	22' 2"
Tub Length	17'
Width	8' 6"
Height	8' 3" at Tub side, 9' 6" at Center
Tub Construction	1/4" Thick, AR400 Steel (or equivalent) 3/16" Thick, AR400 Steel (or equivalent) is optional
Frame Construction	80/100 KSI, Fabricated Steel I-beam
Bumper	Under-Ride Type
Cylinders	3500 PSI, 5" bore
Dolly	Single Axle
Connection	Turntable
Tongue	3" Premier Swivel Drawbar Eye. Premier Tongue Hinge Assembly (poly)
Hinges	Self-Aligning, Spherical Bearing Type (greaseable)
Suspension	Air Ride Suspension Standard; Spring Ride Available
Axles	(2) 25,000# capacity
Hubs	10 Hole, Hub Piloted
ABS	2S1M Anti-Lock Brake System
Drums	Outboard Mount, Cast Steel
Wheels	Steel Disc, 8.25 x 22.5 (8)
Tires	11R 22.5 G Radial Tires (8)
Brakes	16 1/2" x 7"
Fenders	Front & Rear, 1/4" Synthetic, 7 Degree Slope
Lights	12 Volt ICC w/ Sealed Harness
Mud Flap	(2) Polyline Anti-Spray Splash Guard w/SmithCo name
Paint	Polyurethane, any combination of gray, white or black Special colors available upon request

SX1 Tub Capacities

	17' Tub	25' Tub
Waterfull	11.5 cu yd	16.75 cu yd
Heaped	15.5 cu yd	22.5 cu yd

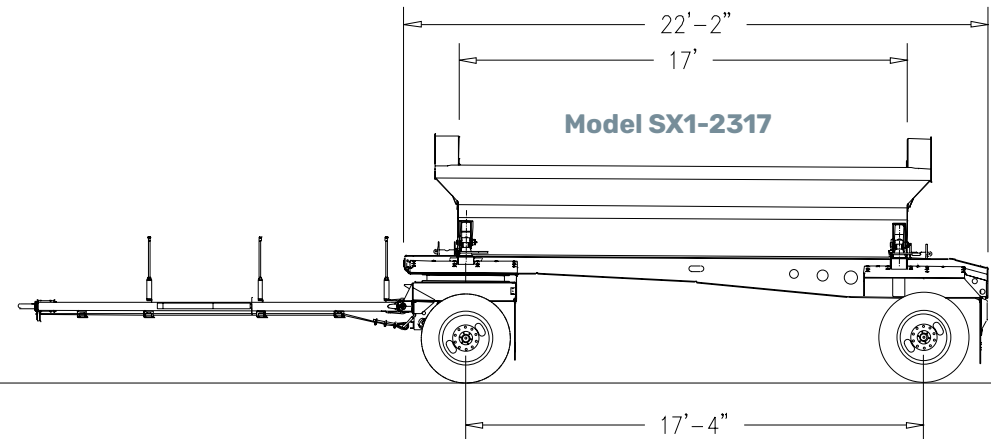
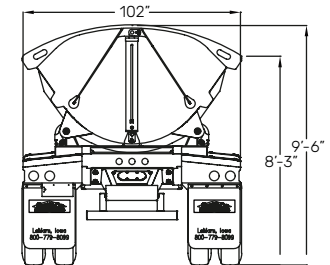

Min. Tractor Hydraulic Reqs.

25-30 GPM, 2,600-2,800 PSI, 10 Gallon Reservoir