



SX5

Five Axle Side Dump Trailer



37' to 49' frame lengths ◀ Stockpile or windrow ▶ Watertight; no leaks ▶ Low load height

800-779-8099 • 712-546-4409 • sidedump.com

SX5
Five Axle Side Dump



SX5

Five Axle Side Dump Trailer

Model SX5-4938 SmithCo Side Dump Trailer

Specs shown are for 49' frame length; other configurations available.

Frame Length	49'
Tub Length	38'
Width	102"
Height	8' 7" at Tub side, 9' 10" at Center
Tub Construction	1/4" Thick, AR450 Steel (or equivalent) 3/16" Thick, AR450 Steel (or equivalent) is optional External Column Supports, No Center Tub Divider
Frame Construction	80/100 KSI, Fabricated Steel I-Beam
Kingpin	2" Kingpin, 18" Setting, Replaceable Type
Landing Gear	Two Speed, Non-Load Bearing
Bumper	Push Bar Type, Bolt-On
Cylinders	3500 PSI, 5" bore
Hinges	Self-Aligning, Spherical Bearing Type (greaseable)
Suspension	Air Ride Suspension Standard Spring Ride Available in Limited Configurations
Axles	(5) 25,000# capacity (1) 16.6K Air Ride/Lift/Steerable 1st axle, (5th axle optional)
Hubs	10 Hole, Hub Piloted
ABS	2S1M Anti-Lock Brake System
Drums	Outboard Mount, Cast Steel
Wheels	Steel Disc, 8.25 X 22.5 (16), 9 X 22.5 on Steerable/lift (2)
Tires	11 R 22.5 G Radial Tires (18); Steer Option: 11 R 22.5 H Radial Tires (16), 295/75 R 22.5 on Steerable/lift (2)
Brakes	16 1/2" x 7"
Fenders	Front & Rear, 1/4" Synthetic, 7 Degree Slope
Lights	12 Volt LED ICC w/Sealed Harness
Mud Flap	(2) Polyline Anti-Spray Splash Guard w/SmithCo name
Paint	Polyurethane, any combination of gray, white or black Special colors available upon request

SX Series Tub Capacities

	34' Tub	36' Tub	38' Tub
Waterfull	23 cu yd	24 cu yd	25 cu yd
Heaped	31 cu yd	32 cu yd	34 cu yd

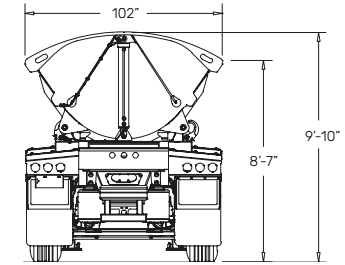

Model SX5-4938

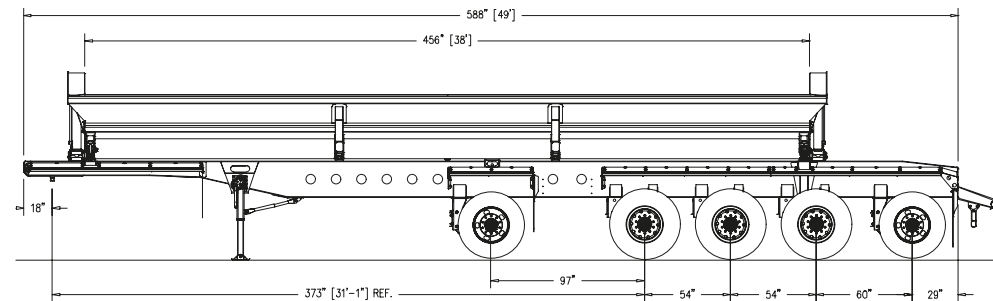

Model SX5-3734-L

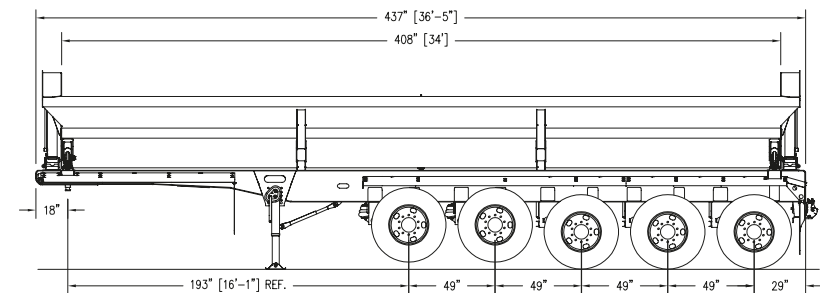

Min. Tractor Hydraulic Reqs.

25-30 GPM, 2,600-2,800 PSI, 10 Gallon Reservoir