

# GEMINI

## WORKTOPS

### WORKTOP OVERHANG BRACKETS - TYPE C - 600mm OVERHANG

INSTALLATION GUIDELINES FOR CUSTOMER REFERENCE

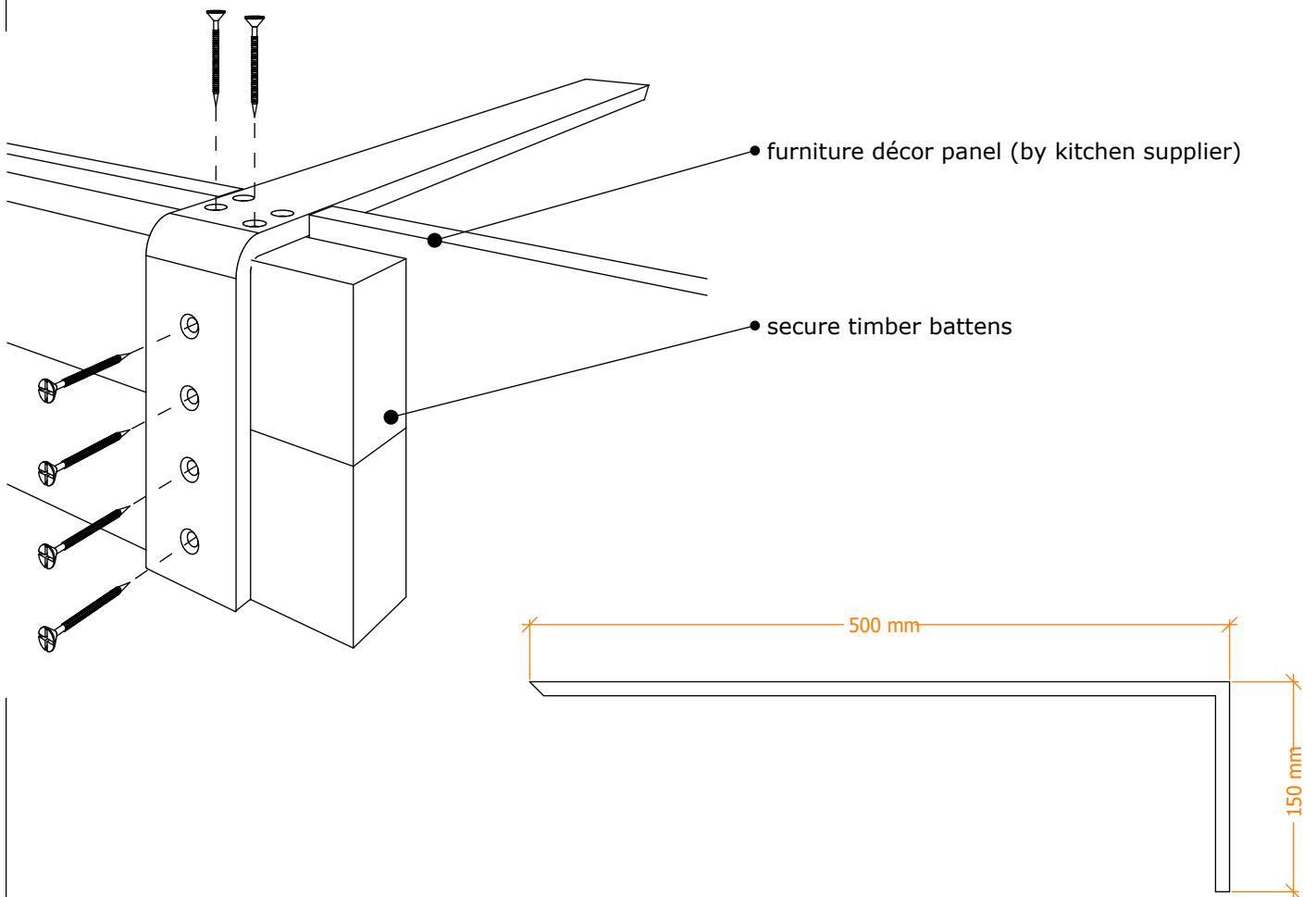

1. Gemini Worktops will deliver your brackets to the site address as noted on your order.
2. The brackets must be installed by your own appointed contractors prior to your Gemini Worktops templating appointment.
3. The overhang bracket will require secure fixing of timber battens to suit your cabinetry (supplied and fixed by your own contractor) onto which the bracket can be fixed. Fixing to chipboard or similar will not be sufficient.
4. Brackets should be positioned at intervals of no more than 600mm apart.
5. The brackets, which are of 10mm thick powder coated steel, should be fixed to the timber which should be fitted behind a furniture décor panel.
6. All required fixings to be supplied by your own appointed contractors.
7. You (the customer) or your contractor assume full responsibility for the secure fitting of brackets.