

GEMINI

WORKTOPS

CONCEALED SHELF BRACKETS - TYPE A - 300mm SHELF DEPTH

INSTALLATION GUIDELINES FOR CUSTOMER REFERENCE

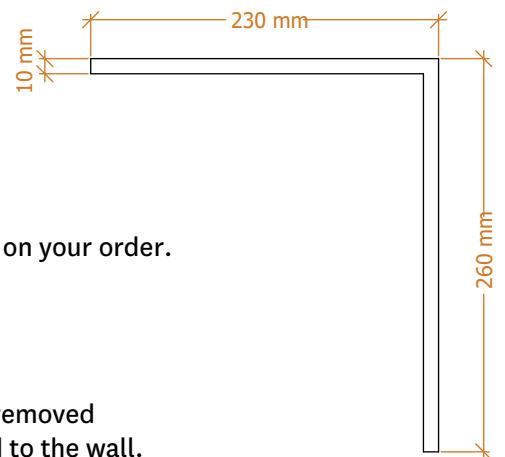
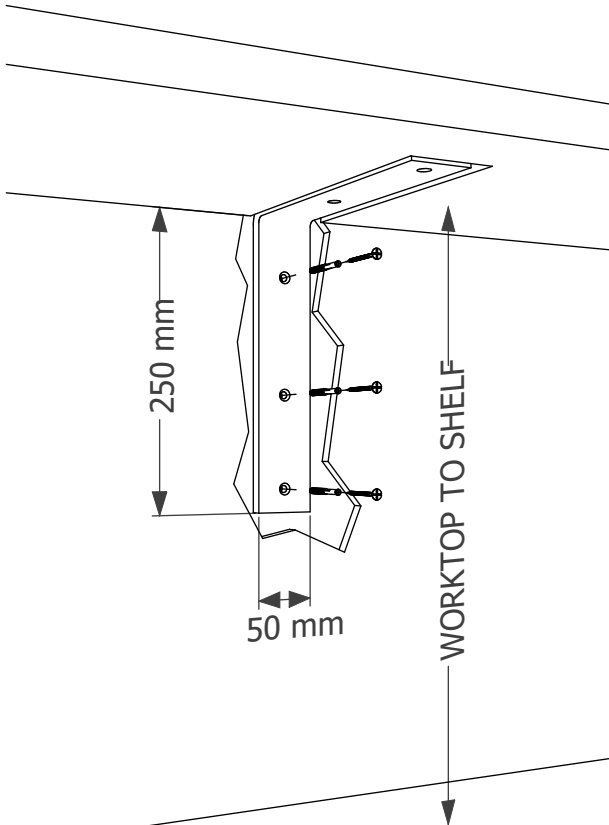

1. Gemini Worktops will deliver your brackets to the site address as noted on your order.
2. The brackets must be installed by your own appointed contractors prior to your Gemini Worktops templating appointment.
3. Walls where brackets are to be installed, should have the plasterwork removed and the masonry exposed in the positions where the brackets will be fixed to the wall. This work to be carried out by your own contractors.
4. Brackets should be positioned at intervals of no more than 600mm apart.
5. The brackets, which are of 10mm thick powder coated steel, should be fixed to the masonry wall allowing for the decorative wall covering / cladding to be fitted directly to the plastered wall face, and to cover the wall mounted bracket fixing.
6. All required fixings to be supplied by your own appointed contractors.
7. You (the customer) or your contractor assume full responsibility for the secure fitting of brackets.