

# SPINNER II®

OIL CLEANING CENTRIFUGE

**Model 976** Lo Flo  
Transit

Installation Instructions

Parts List

Service Instructions

Part No. 73215-1 GPM



### Three connections are required at the centrifuge:

1. Oil Inlet (½-in. NPT Female Pipe) – *Unscrew plastic shipping plug.* Run #8 hose from point of highest pressure.
2. Oil Outlet (½-in. NPT Female Pipe) – *Unscrew plastic shipping plug.* Run #8 hose to crankcase above oil level.
3. Air Inlet (¼-in. NPT Female Pipe) – *Unscrew plastic shipping plug.* Run #4 hose from any convenient point on air supply to air valve cartridge inlet. *Do not remove cartridge — loss of cartridge seal will damage unit.*

**CAUTION** — Route hoses to clear exhaust and all moving parts and fasten securely. Be certain pressure oil supply is to OIL IN port on side of centrifuge and return to crankcase is from OIL OUT port on bottom. *Do not remove full-flow filters.* Use the Spinner II centrifuge *only* as a bypass oil cleaner. Remove any previously installed bypass filters prior to installation of the Spinner II, and block ports where necessary.

### Detailed Information Available

For optimum performance of your centrifuge, specific installation drawings for almost any diesel engine can be requested from your distributor.

## General Instructions

### Dirty Oil Supply to Centrifuge Oil Inlet

**Pressure Tap on Engine** — Most engines, including the latest models from Cummins, Caterpillar, DDC and Mack, provide a ⅜-in. or ½-in. port to supply an auxiliary device. Avoid using end-of-gallery supply points such as the pressure gauge tap. **Note on COV (Cut-Out Valve):** Idle cut-out valve prevents oil flow into centrifuge at pressures less than 19 psig.

### Clean Oil Outlet Return to Crankcase

**Return Opening in Crankcase** — Most engines have a ½-in. or larger oil return opening provided in the crankcase wall. If unrestricted, this is an ideal oil outlet line connection point.

**Special Return Problems** — If there are no available drain openings, it may be necessary to drill and tap an inspection plate. Remove the plate before modification and avoid directing the return flow directly onto moving parts. Request assistance from your distributor.

### Air Supply

Air for the control mechanism can be taken from any convenient place on the vehicle air system where there is a constant supply of air, preferably from the dry tank. ⅜-in. nylon tubing is sufficient or #4 hose can be used if preferred. Air pressure can vary from 35 to 125 psig. No regulators, valves or control devices are required. The Spinner II control automatically shuts off the air supply when the engine stops. 0.02 SCFM air consumption is almost too small to measure.

**Note:** The control mechanism can be operated on bleed air taken from the turbocharger manifold if compressed air is not available. The standard air valve must be replaced by Part #72137 low-pressure air valve cartridge which includes a pre-filter Part #71246. Request Bulletin 86.020 for details.

## Spinner II/976 Net Weight 11.02 lb (5.0 kg)

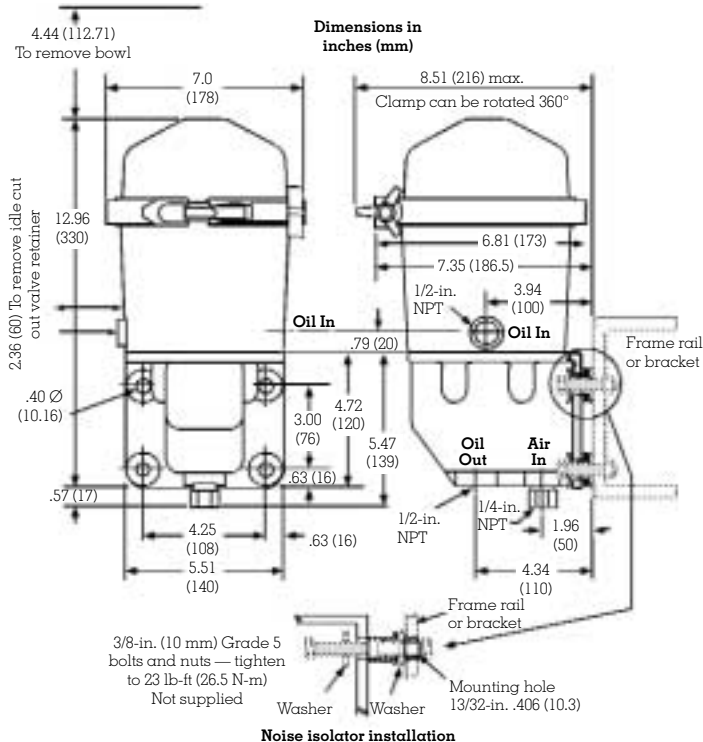

### Mounting Location

**Install Vertically ±10°.** The frame rail is the preferred location for mounting the centrifuge. A Spinner II Part 70845 spacer is available to facilitate inside frame rail mounting, requiring only two holes in the rail. Check with manufacturer before drilling. Bulletin 71294 contains a drilling template. Additionally, a Spinner II Part 71421 No-Drill mounting bracket kit is also available. Use this kit when installation will not permit drilling of the frame rail. The Spinner II centrifuge is a high-speed device and is provided with noise isolators for operator comfort, which must be installed as shown above. Care should be used to prevent metal-to-metal contact with the frame or body, which might result in unnecessary noise or vibration. The cover clamp can be rotated to any convenient position and *tightened by hand only.*

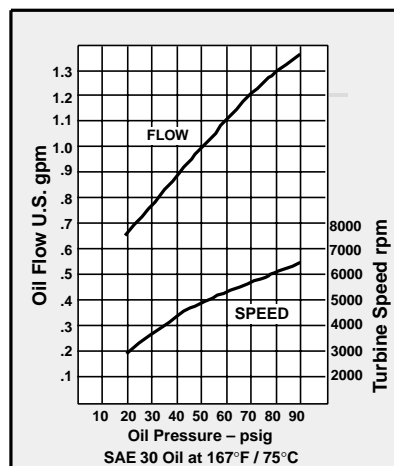

# Model 976 Lo Flo (Part No. 73215) Parts List

Item	Description	Part number
Only items shown with part numbers are available. <b>Bold denotes assembly</b>		
	<b>Centrifuge, Spinner II/Model 976 complete</b> .....	<b>73215</b>
	<b>Service kit, clean bowl (1 each items c, l and n)</b> .....	<b>73265</b>
<b>a</b>	Cover .....	73191
<b>b</b>	<b>Clamp, cover to base</b> .....	<b>71266</b>
	Tee bolt and knob clamp .....	71270
<b>c</b>	Seal-cover, Viton® .....	71264
	<b>Cover assembly</b> .....	<b>73266</b>
<b>h</b>	Nut-centrifuge bowl .....	73239
<b>k</b>	Bowl-centrifuge .....	73196
<b>l</b>	Insert, paper-centrifuge bowl (pkg. of 50) .....	73165
<b>n</b>	Seal-centrifuge bowl, Viton .....	73240
<b>m</b>	Baffle/screen-centrifuge .....	73197
<b>u</b>	Body-centrifuge turbine (white) .....	73237
<b>d</b>	<b>Centrifuge turbine assembly (white)</b> .....	<b>73271</b>
	(includes items <b>h, k, l, m, n</b> and <b>u</b> )	
<b>e</b>	<b>Housing assembly</b> .....	<b>73233</b>
■ <b>s</b>	<b>Repair kit-idle cut-out valve</b> .....	<b>71053</b>
<b>t</b>	<b>Seal-idle cut-out valve</b> .....	<b>71054</b>
<b>g</b>	<b>Control mechanism assembly</b> .....	<b>70675</b>
	Screw, hex head cap-control mechanism .....	70673
	M10 x 35 mm (available locally)	
■ <b>f</b>	Seal-control mechanism (Viton) .....	70996
	<b>Repair kit-control float mechanism</b> .....	<b>71445</b>
<b>p</b>	<b>Kit-isolator, noise, with washers (set of 4)</b> .....	<b>71173</b>
	( $\frac{3}{8}$ -in. grade 5 bolts and nuts not supplied)	
■ <b>q</b>	<b>Cartridge-air valve assembly (includes item r)</b> .....	<b>70938</b>
	(optional assembly for turbo air supply - 72137)	
<b>r</b>	Seal-air valve cartridge, Viton .....	70966

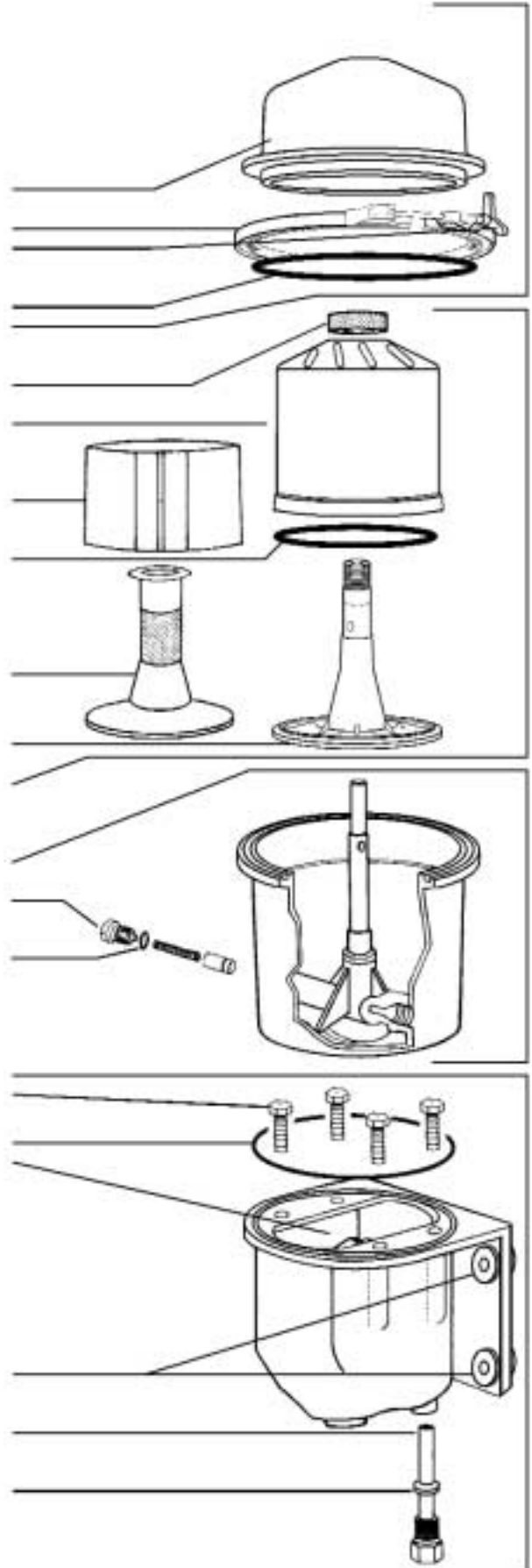
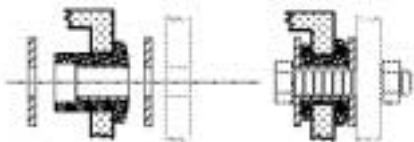

**Service Cycle** ■ At unit rebuild or when required.

### Refer to Parts List illustration

1. Shut off engine and allow centrifuge turbine assembly (d) to come to a complete stop.
2. Loosen handle on clamp (b), disengage tee bolt and remove cover (a), using coin in gap to separate cover from housing.
3. Partially withdraw centrifuge turbine assembly (d) from the housing (e) and allow oil to drain from nozzles (o) before removing completely. Hold the centrifuge turbine assembly in one hand and loosen knurled bowl nut (h) several turns until the face of the nut projects beyond the bronze bushing face. Carefully separate centrifuge bowl (k) from turbine body (u) by striking the face of the nut (h) with the palm of one hand while holding the bowl in the other. Do not strike the nut or the bushing with or against a hard surface or damage will result. Finish removing the nut and then remove the bowl and baffle/screen (m).
4. Simply replace the dirty centrifuge bowl with a new one or carefully remove the dirt cake from the bowl (k) using a wooden spatula or other non-damaging tool. Wipe out bowl with solvent. Note: To save time in cleaning, an optional die-cut Bristol paper insert (l) is available as a service part and may be installed to allow the compressed cake to be removed quickly.
5. Wash and clean baffle/screen (m) and turbine body (u), removing and inspecting Viton bowl seal (n). Replace Viton seal if damaged.
6. Inspect top and bottom bushings of centrifuge turbine body (u). Replace turbine assembly if bushings show severe wear. Reassemble: Place baffle/screen (m) over stem of turbine body and seat evenly over shoulder on base. Install bowl seal (n) in recess in outer edge of turbine base. Slide a new centrifuge bowl (k) over stem and seat uniformly over bowl seal. Install and tighten knurled bowl nut (h) securely, using finger pressure only.
7. Inspect housing assembly (e) paying special attention to journal areas of spindle. Replace housing if damaged.

### Top view with centrifuge removed

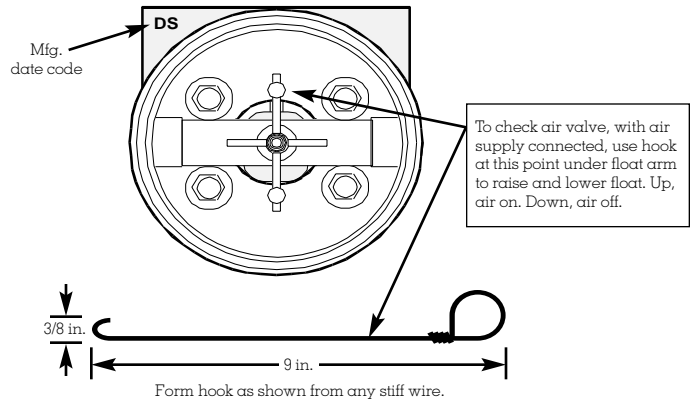

8. Clean and inspect cover (a). Always remove the old cover seal (c), clean the groove in the housing and mating surface of the cover. Examine the Viton seal and replace if damaged. The seal is Viton and can be reused several times.
9. Check control mechanism (g) — see diagram above.
10. Be certain centrifuge turbine base is colored WHITE to indicate 1 gpm nozzles. Install centrifuge turbine assembly (d) on spindle. Be sure it rotates freely. Replace cover (a), position clamp (b) uniformly over cover and housing flanges, and tighten clamp handle securely by hand pressure only.
11. With the engine running, check all connections and joints for leaks.

## Trouble-Shooting

### Centrifuge removes too little dirt

#### Check for Proper Operation

Warm up engine and then bring engine to normal speed for one minute and immediately shut it down. If the Spinner II unit is working correctly the turbine can be heard spinning. As with any high-speed device, it may go through momentary periods of vibration as it passes through critical speeds while slowing to a stop. This is normal. If the turbine is not spinning or if vibration is severe or continuous at all speeds, an error may have been made in assembly. Repeat steps 1 to 10, paying special attention to the proper seating of baffle/screen (m), the bowl seal (n) (Step 6) and the control mechanism (Step 9). If vibration persists, substitute a different centrifuge turbine assembly (d).

If the turbine is spinning properly, the centrifuge is doing its job of removing harmful abrasive dirt regardless of the amount of deposit found in the bowl. The visible deposit is largely soot and its thickness will vary from 1/8-in. to completely full depending on oil type, oil change interval, engine type and condition, and operating conditions. Oil additive package design will affect soot size and thus the amount of carbon and soot collected in the bowl.

### Control air valve problems

Float valve flows air constantly or not at all, up or down.

Air tank bleeds down overnight.

#### Check Valve (Step 9)

Most air control problems can be repaired without dismounting the centrifuge by renewing the air valve cartridge (q), making certain that air valve cartridge seal Part 70966 (r) is in place. A cartridge installed without the seal will be damaged and will leak continuously. If the float mechanism is worn or broken, the centrifuge must be disassembled and repaired with control float mechanism repair kit Part 71445. Instructions are contained in the kit. Caution: The valve cores in the air valve cartridge are special, low operating force-type with Viton seals to withstand hot oil. Do not substitute tire valve cores — replace the entire cartridge.

### Oil leaks

#### Cover Seal

Remove cover (a) and cover seal (c). Clean seal grooves in housing and mating surface on cover. Install a new cover seal (b) in the housing groove, replace cover (a), position clamp (b) uniformly over cover and housing flanges, and tighten clamp handle securely by hand pressure only.

#### Body to Control Mechanism Seal

Remove cover and centrifuge turbine assembly. Remove control mechanism by loosening four cap screws. Discard seal (f) and clean groove and mating surfaces. Replace seal with a new one and retighten cap screws alternately to 35 lb-ft torque. It is possible to rotate the body 180° if it is necessary to locate the oil inlet port on the left side. Replace the seal and retighten bolts. Continue from Step 3 above.

#### Oil Line Connections

Disconnect leaking hose and remove hose adapter from port. Clean threads in port and on adapter, and inspect for damage. Reinstall adapter using a good liquid thread sealant. Reconnect hose.

## Sales and Service

# SPINNER II® PRODUCTS



**T. F. HUDGINS  
INCORPORATED**

Tel: 713-682-3651 or 800-231-7746  
 Fax: 713-681-9702  
 Mail: P.O. Box 920946  
 Houston, Texas USA 77292-0946  
 Warehouse: 4405 Directors Row  
 Houston, Texas USA 77092  
 Web Site: www.Spinnerii.com